

PUMPS

HD50 - HD65 - HDX65 - HDX80 - HD80 - HD100

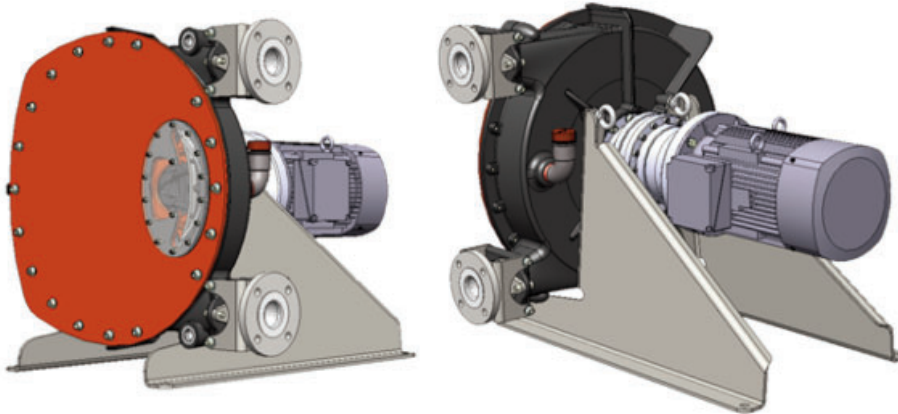

Installation
Operation
Maintenance

EC CERTIFICATE OF CONFORMITY :

The EC Certificate of Conformity (paper version) is systematically attached to the equipment when shipped.

WARRANTY :

ABAQUE pumps are covered 24 months by warranty within the limits mentioned in our General Sales Conditions. In case of a use other than that mentioned in the Instructions manual, and without preliminary agreement of ABAQUE, warranty will be canceled.

PATENTS :

For relevant patents on this product refer to : www.psgdover.com/abaque/support/patents



Z.I. La Plaine des Isles - F 89000 AUXERRE - FRANCE
Tél. : +33 (0)3.86.49.86.30 - Fax : +33 (0)3.86.49.87.17
contact.abaque@psgdover.com • www.psgdover.com/abaque

Your distributor :

ABAQUE PERISTALTIC HOSE PUMPS

SAFETY INSTRUCTIONS, STORAGE, INSTALLATION AND MAINTENANCE

TECHNICAL CHARACTERISTICS

• Maximum flowrate :

• Intermittent service :

	HD50	HD65	HDX65	HDX80	HD80	HD100
m ³ /h	15,3	18,2	26	34,7	39	54
GPM	67,36	80,13	114,47	152,78	171,71	197,97

• Continuous service :

	HD50	HD65	HDX65	HDX80	HD80	HD100
m ³ /h	9,3	11	17	22,5	23,6	36
GPM	40,95	48,43	74,85	99,06	103,91	131,98

• Maximum rotation speed :

• Intermittent service :

	HD50	HD65	HDX65	HDX80	HD80	HD100
tr/min (rpm)	90	90	65	65	60	45

• Continuous service :

	HD50	HD65	HDX65	HDX80	HD80	HD100
tr/min (rpm)	56	56	42	42	36	30

• Maximum running temperature :

- Hose NR - NBR - NBR FDA - Hypalon .70°C (158°F)
- Hose EPDM80°C (176°F)

• Minimum running temperature : .0°C (32°F)

• Maximum pressure15 bar (217 psi)

• Maximum viscosity :

	HD50	HD65	HDX65	HDX80	HD80	HD100
cP	18 000	40 000	30 000	55 000	27 000	63 000

Definition of safety symbols



This is a SAFETY ALERT SYMBOL.

When you see this symbol on the product, or in the manual, look for one of the following signal words and be alert to the potential for personal injury, death or major property damage.



Warns of hazards that WILL cause serious personal injury, death or major property damage.



Warns of hazards that CAN cause serious personal injury, death or major property damage.



Warns of hazards that CAN cause personal injury or property damage.

NOTICE

Indicates special instructions which are very important and must be followed.

TABLE OF CONTENTS

Page

1. OVERALL DIMENSIONS	3
2. INSTALLATION	7
2.1 Operating principle	7
2.2 Hose compression	7
2.3 Pumped liquid	7
2.4 Piping installation	7
2.5 Rotation direction	8
2.6 Highly solid loaded liquids	8
2.7 Operation with vacuum on suction	9
2.8 Lifting	9
2.9 Pump location	9
2.10 Anchoring the pump	9
2.11 Electric motors	9
3. OPERATION	10
3.1 Pump storage	10
3.2 Hose storage	10
3.3 Hot liquids pumping	10
3.4 Pump stopped with liquid inside	10
3.5 Starting the pump	10
3.6 Stopping the pump	10
3.7 Hose burst	10
3.8 Scrapping	10
4. MAINTENANCE	11
4.1 Lubricant replacement	12
4.2 Hose replacement	12
4.3 Rotor assembly removal	15
4.4 Shaft seals replacement	17
4.5 Shoes replacement	19
4.6 Pump pressure setting	20
5. TROUBLESHOOTING	21

NOTES

The ABAQUE peristaltic pumps **MUST** be installed on systems specially designed by qualified staff. Installation **MUST** comply with local standards, national rules and safety regulations.

This manual is designed for installation and start-up of the peristaltic pumps. It **MUST** be supplied with the pump.

Maintenance of the peristaltic pumps must be carried out **ONLY** by qualified personnel. This operation must comply with local and national regulations as well as safety standards.

Read the whole manual and all the instructions and precautions, **BEFORE** using any ABAQUE pumps.

Do not remove any warning and use stickers from the pumps.

NOTES

The numbers after part names correspond to reference numbers in the spare parts lists.

Photos and drawings used in this IOM are not contractual.

1. OVERALL DIMENSIONS

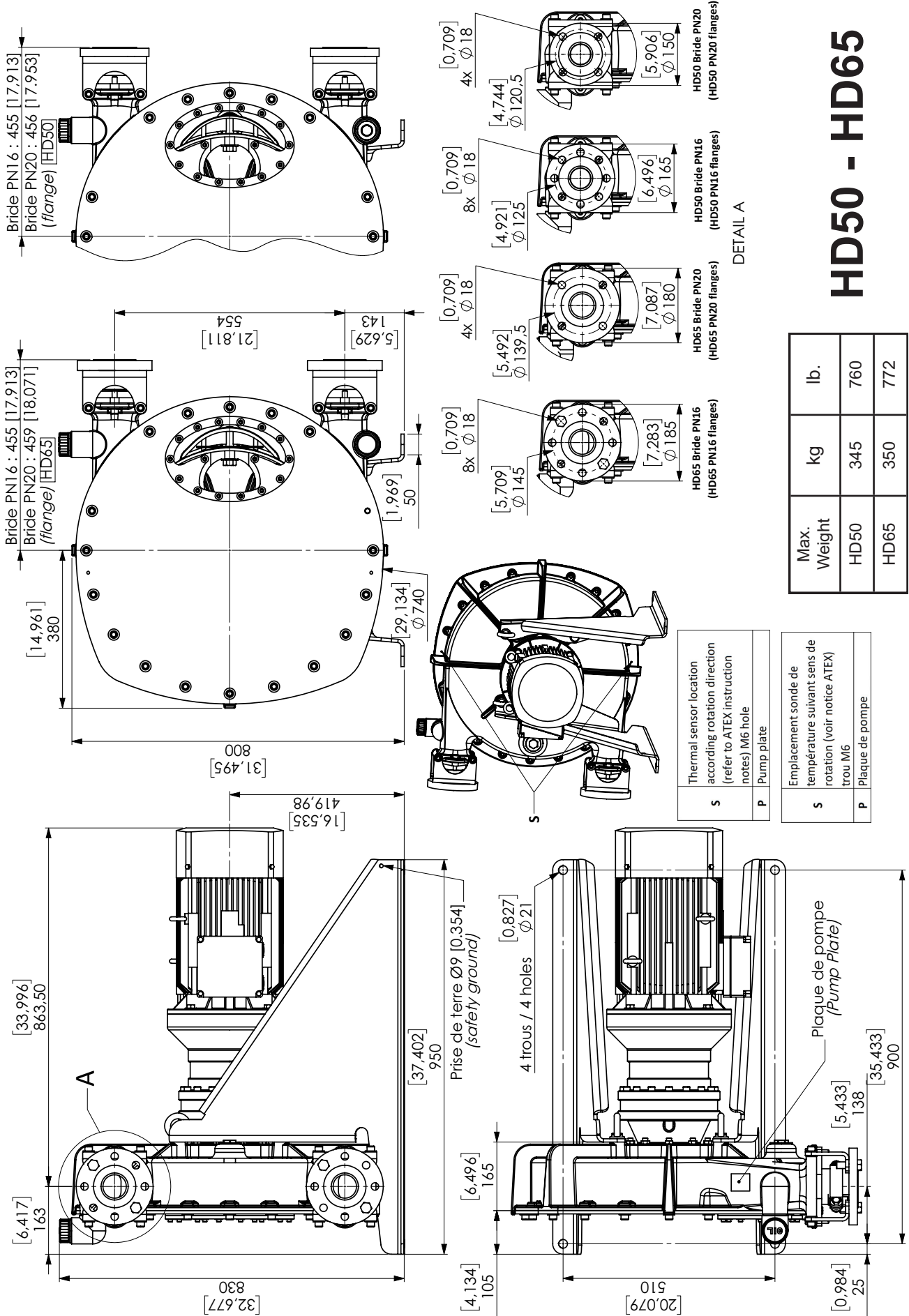

HD50 - HD65

DETAIL A

1. OVERALL DIMENSIONS (continued)

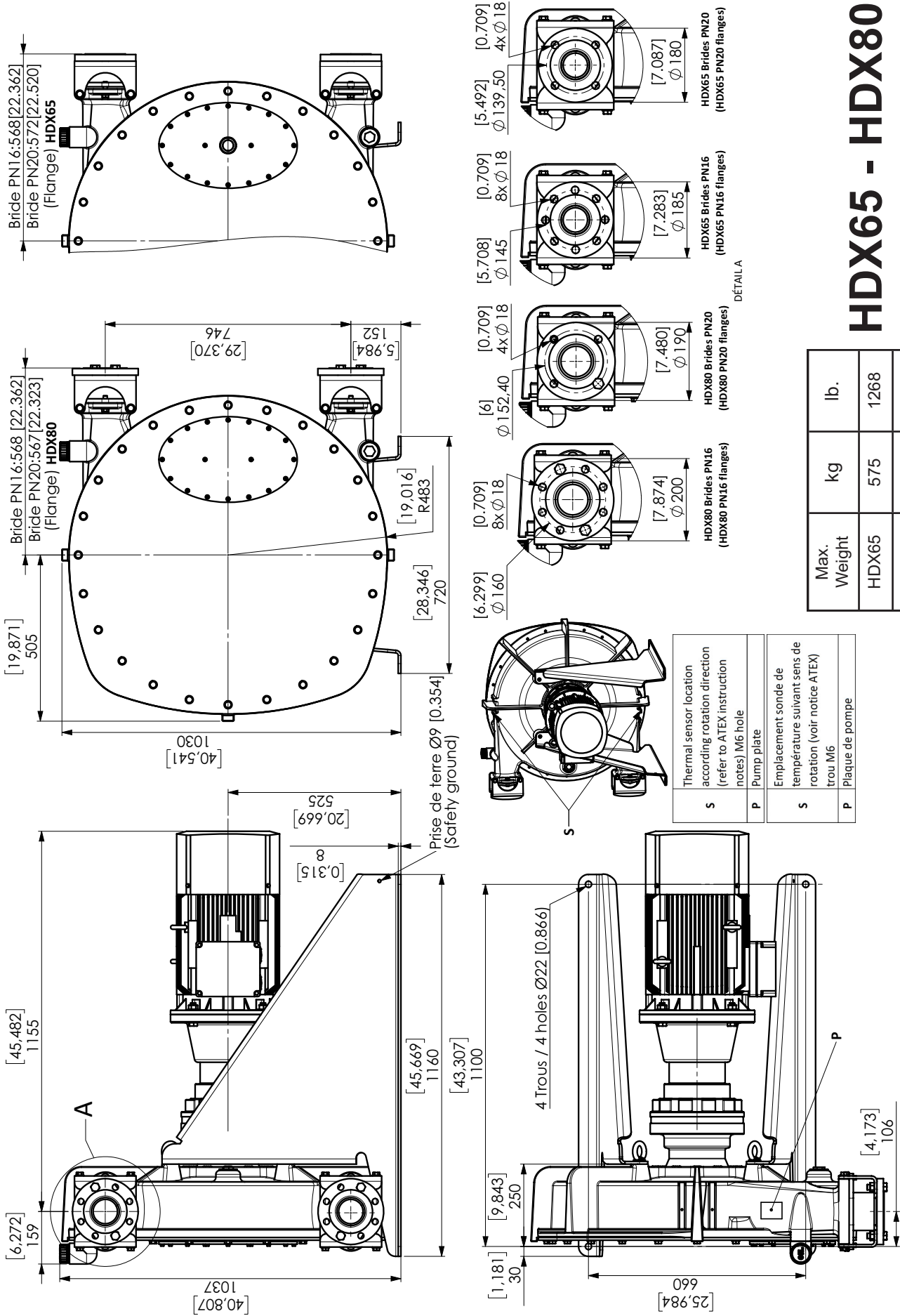

HDX65 - HDX80

Max. Weight	kg	lb.
HDX65	575	1268
HDX80	580	1279

1. OVERALL DIMENSIONS (continued)

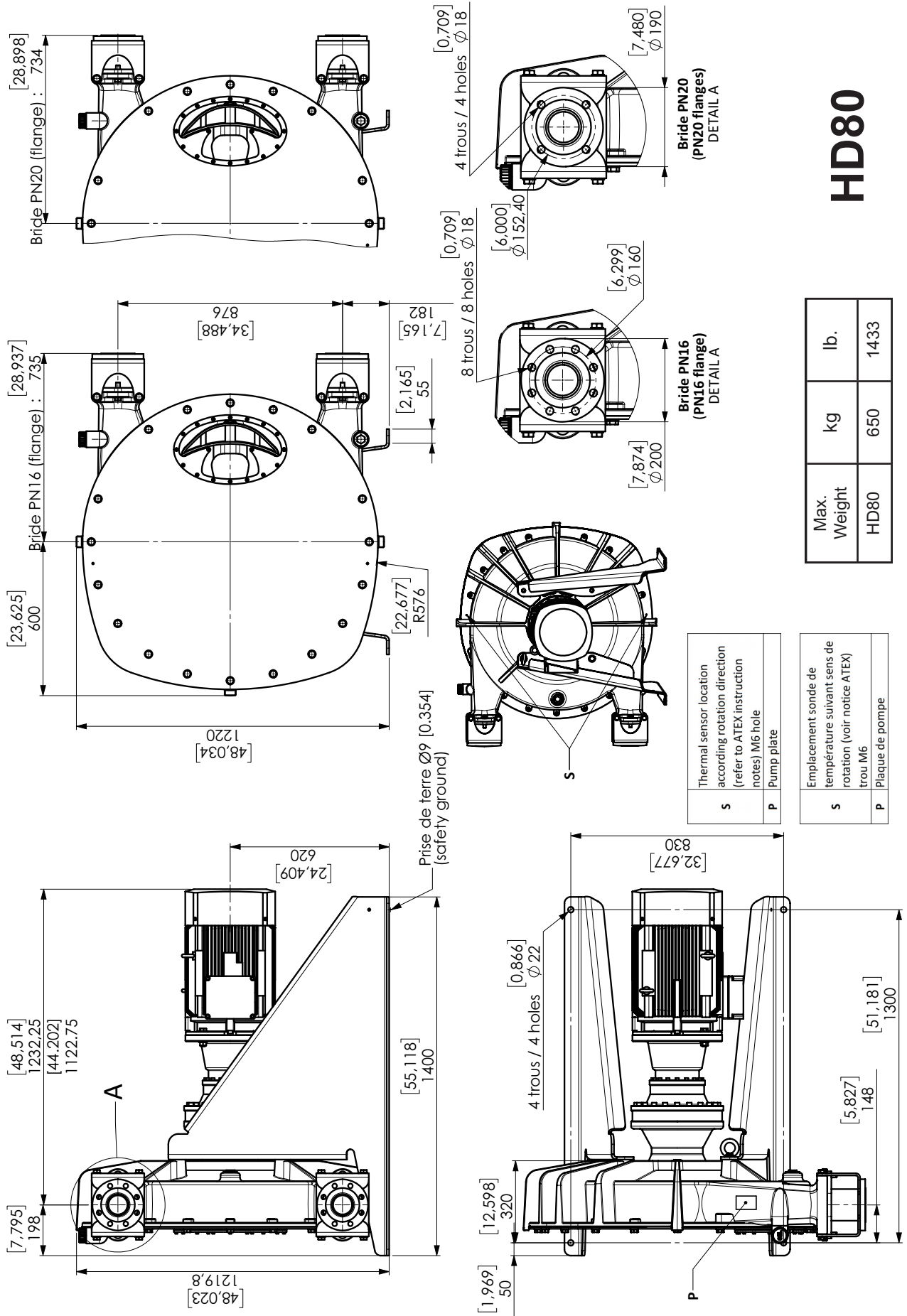

1. OVERALL DIMENSIONS (continued)

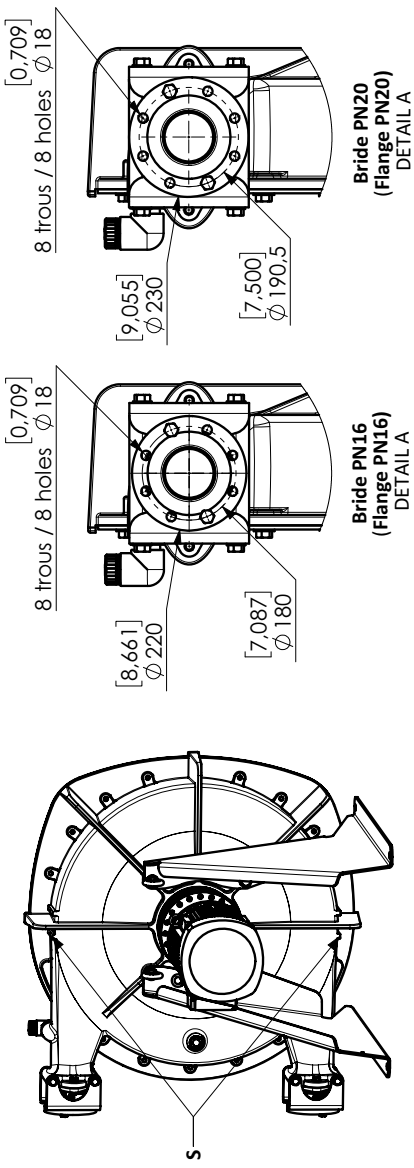
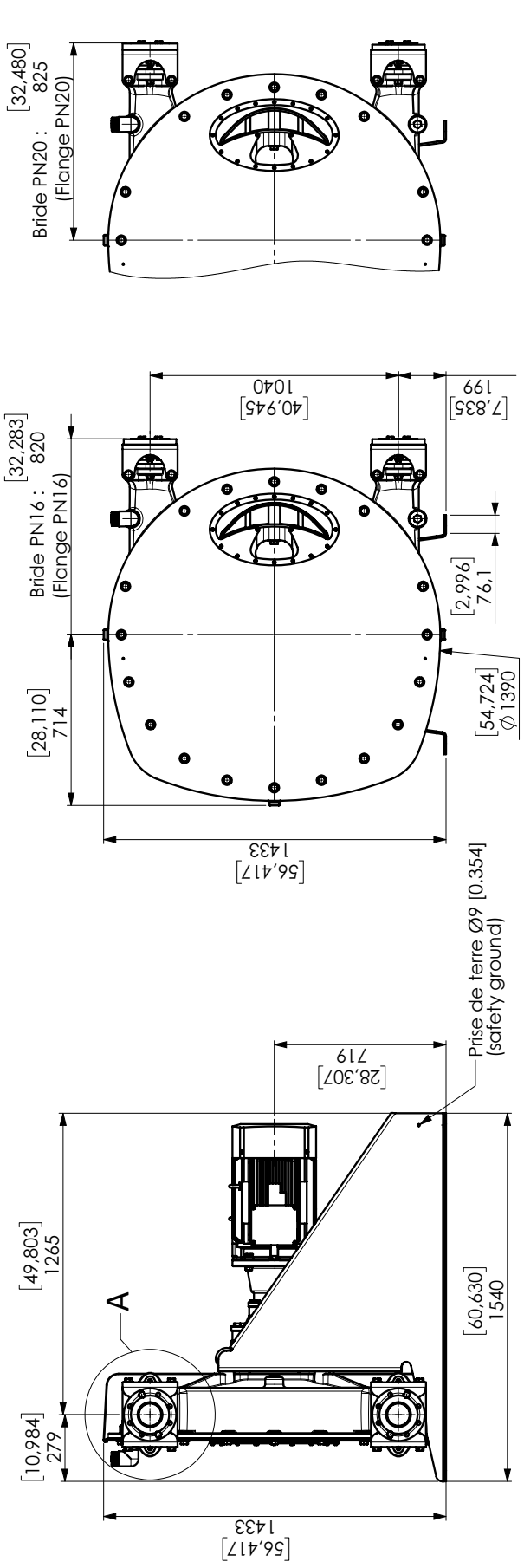

S	Thermal sensor location according rotation direction (refer to ATEX instruction notes) M6 hole
P	Pump plate
S	Emplacement sonde de température suivant sens de rotation (voir notice ATEX) trou M6
P	Plaque de pompe

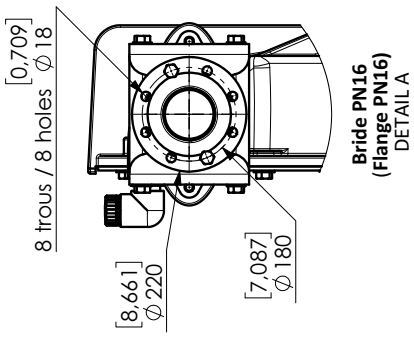
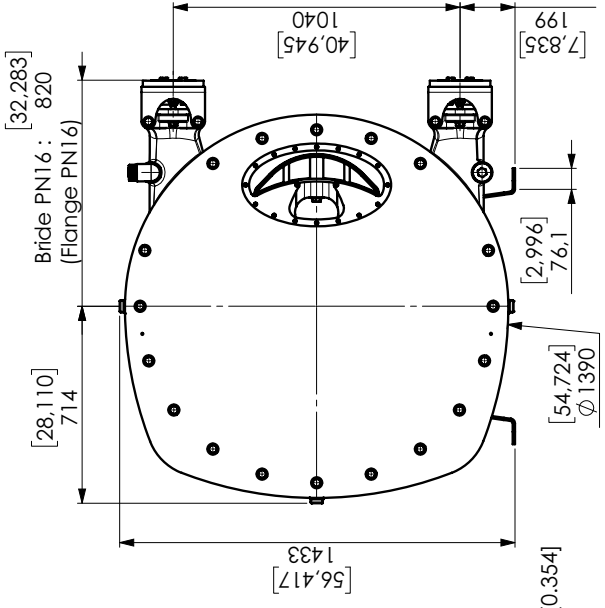
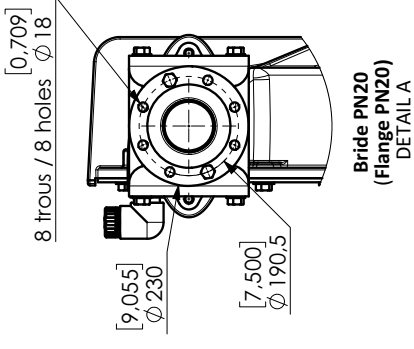
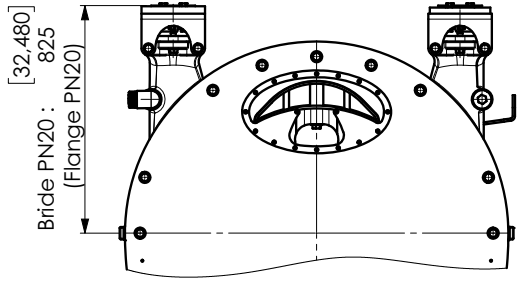
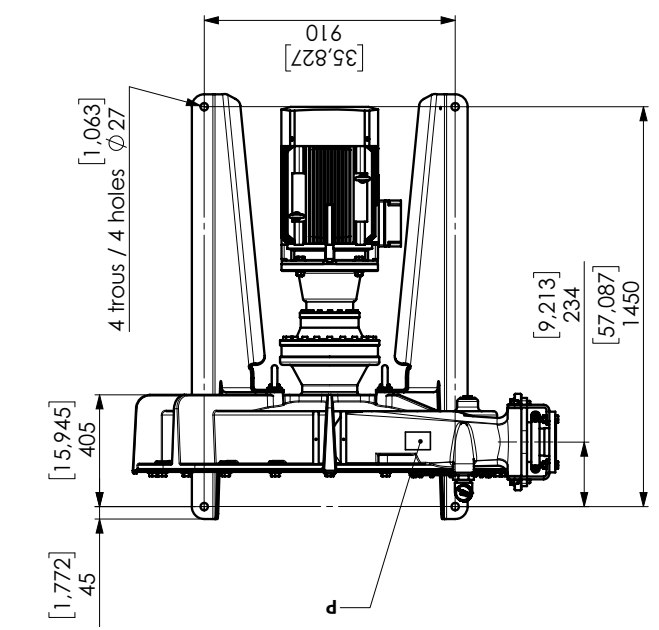

HD100

Max. Weight	kg	lb.
HD100	870	1918

2. INSTALLATION

2.1 Operating principle

The pump operates by alternating contraction and relaxation of a specially designed elastomeric hose.

Two shoes attached 180° apart to a central rotor compress the hose against the pump body in a fluid tight manner.

Rotation of the rotor causes a flow by displacing the product into the hose. The pump body is filled with a special lubricant allowing shoes to slide easily over the hose, which avoids overheating.

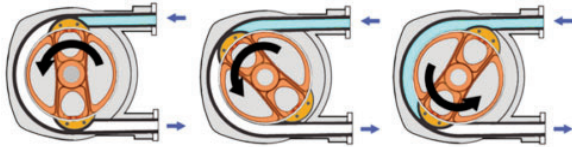

2.2 Hose compression

Performance and durability of the hose are guaranteed by inserting an adequate number of shims under the two shoes (see § PUMP PRESSURE SETTING).

2.3 Pumped liquid

Under normal operation, the pumped liquid is only in contact with the hose and the inserts. Chemical compatibility between pumped liquid and these two parts must therefore be carefully checked.

Five different quality elastomeric hoses are available :

- NR (natural rubber)
- NBR (perbunan or buna)
- NBR FDA (food perbunan or buna)
- EPDM
- Hypalon



Inserts are available in AISI 316 stainless steel, in polypropylene (PPH) and in polyfluoride vinylidene (PVDF).

This pumping technology is specially adapted to handle abrasive and solid loaded liquids.

During the compression stage, abrasive particles may penetrate the hose wall without damaging it. Immediately after, these particles are released into the liquid (the size of particles does not however have to exceed 15 % of the internal diameter of the hose).

You can contact our Technical Services at any time to ask for the information you require.

2.4 Piping installation

 WARNING	<p>FAILURE TO RELIEVE THE SYSTEM PRESSURE PRIOR TO PERFORMING ANY WORK ON THE PUMP OR THE INSTALLATION CAN CAUSE PERSONAL INJURY OR PROPERTY DAMAGE.</p>
 <p>Hazardous pressure can cause personal injury or property damage.</p>	



Not recommended



To be avoided if possible



Preferable

Make suction line as short and straight as possible.

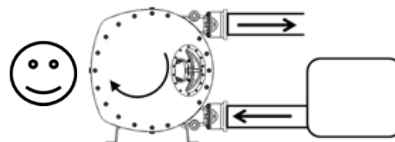
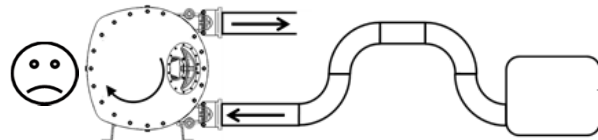
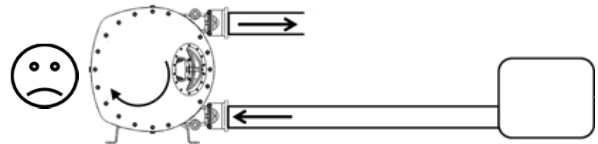

Avoid multiplying pipe bends.

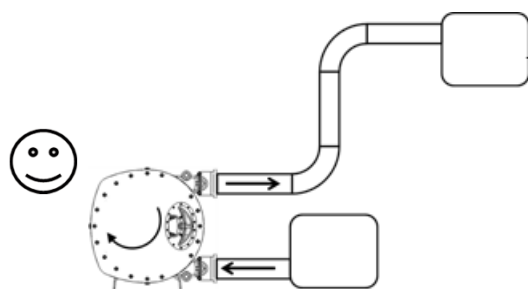
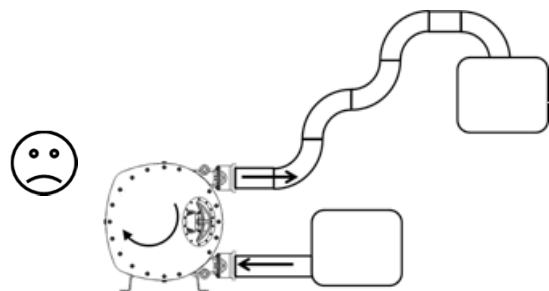

2. INSTALLATION (continued)

Use of a dead-end pulsation dampener

To obtain a maximum efficiency of the dampener, it should be placed as close as possible to pump port, and with inlet port facing full flow rather than being on a T junction.

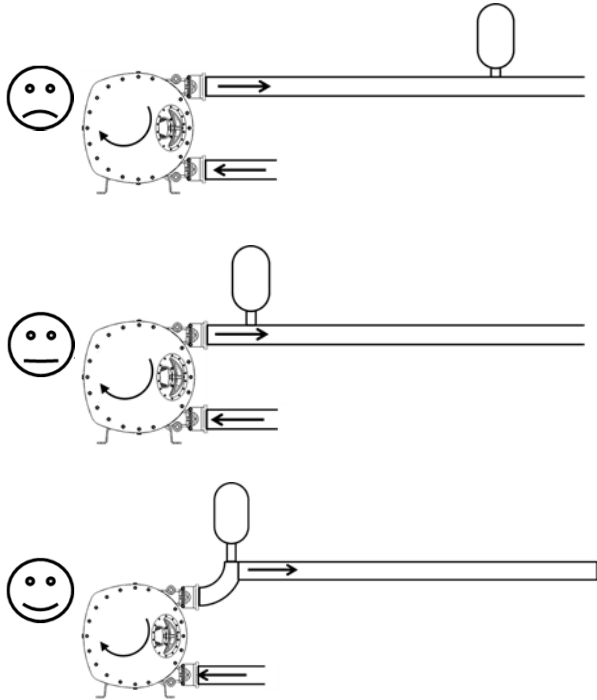

Use of an in-line pulsation dampener

To obtain a maximum efficiency of the dampener, it should be placed as close as possible to pump port.

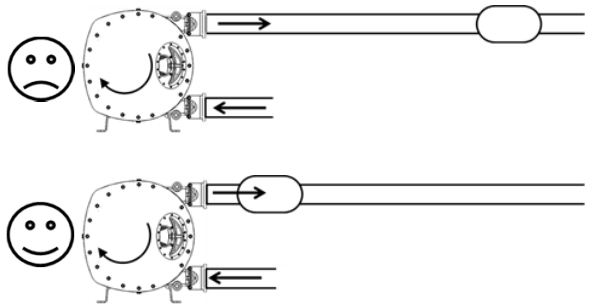

Change pumping set or pump ports position rather than multiplying pipe bends.

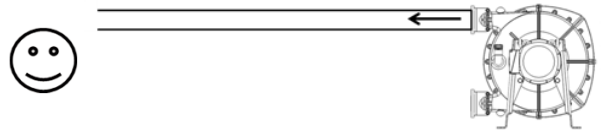
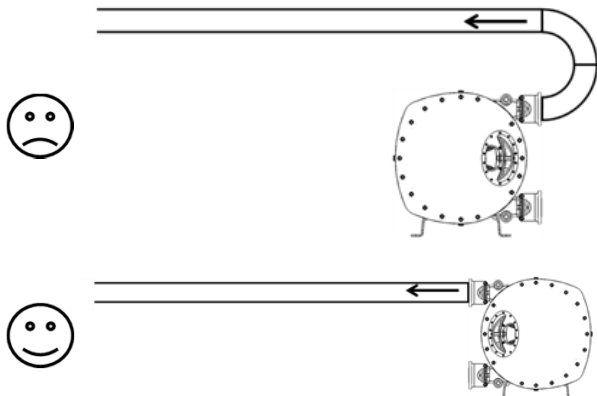

For hoses fitting on pump suction or discharge, a hose whip restrain device must be installed to limit the whip or travel of the pressurized hose at start up, or in case the hose breaks free.



WARNING: SEVERE PERSONAL INJURY OR PROPERTY DAMAGE CAN CAUSE FROM WHIPPING HOSES.

2.5 Rotation direction



WARNING



Hazardous pressure can cause personal injury or property damage.

FAILURE TO RELIEVE THE SYSTEM PRESSURE PRIOR TO PERFORMING ANY WORK ON THE PUMP OR THE INSTALLATION CAN CAUSE PERSONAL INJURY OR PROPERTY DAMAGE.

The ABAQUE pump is reversible; this allows it to always circulate the liquid in the desired direction by choosing the corresponding direction of rotation.

The intake and discharge sides are determined as follows : When an observer is placed on pump cover side (opposite to the shaft output), if rotation takes place clockwise, the intake is on the bottom, on the contrary if the rotation is anticlockwise, the intake is on the top.

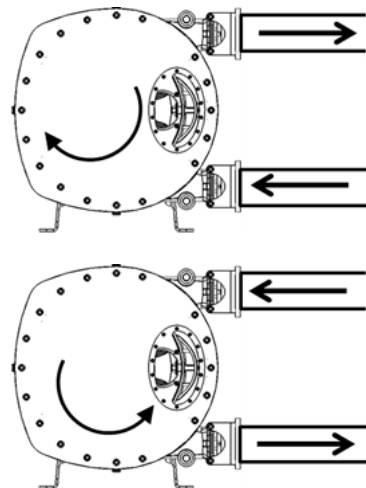

2.6 Highly solid loaded liquids

In the case where the pumped fluid contains particles, use the upper flange as the inlet flange.

This facilitates discharge of the sediments formed by the build-up of the particles contained in the fluid, so this reduces friction between the hose and the shoes. Therefore, the pump may be re-started more easily.

2. INSTALLATION (continued)

2.7 Operation with vacuum on suction

Because of the operating principle of the pump, using it with suction pressure lower than the atmospheric pressure will cause a resulting loss of flow more or less in line with the conditions of the application (hose material, rotation speed, temperature, etc.).

In order for the pump to generate the normally required flow, ABAQUE recommends using a vacuum draw kit inside the body of the pump.

In all cases, when using a vacuum kit, suction pressure must not be lower than -0,9 barg (-13 psig).

If a vacuum draw kit is not used on an ABAQUE pump operating with suction pressure lower than atmospheric pressure, ABAQUE no longer guarantees the performance of the pump.

2.8 Lifting

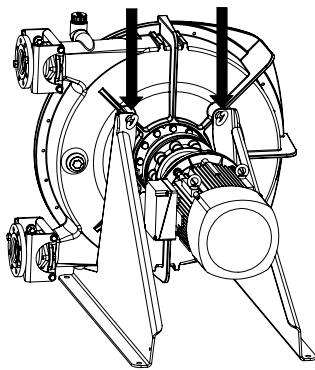

**USE SUITABLE LIFTING DEVICES FOR HANDLING.
USE THE LIFTING RINGS PROVIDED.**

Maximum pump weight : see § OVERALL DIMENSIONS.

2.9 Pump location

Provide sufficient clearance around the pump for maintenance operations.

Particularly, make sure that there is sufficient clearance for replacing the hose; the distance between the pump flanges and the closest obstacle must allow the hose to be removed, as shown below :



Distance A :

	HD50	HD65	HDX65	HDX80	HD80	HD100
mm	1400	1400	1600	1600	2000	2800
inch	55	55	62,992	62,992	78,74	110,236

2.10 Anchoring the pump

The correct seating of the pump is vital for its efficient operation and its longevity.

The surface must be resistant enough to absorb the stresses due to the pump unit without deformation.

In the case where the unit is fastened by anchor lugs or bolts, it must be carefully wedged to prevent any deformation of the chassis when tightening the bolts.

2.11 Electric motors

 WARNING	<p>DISCONNECT THE ELECTRICITY SUPPLY BEFORE ANY MAINTENANCE OPERATION.</p>
<p>Dangerous voltage. Can cause injury and death.</p>	

Check that the supply voltage matches the indications on the motor rating plate.

Comply with the wiring diagram, make sure the wires are rated for the power and take care with the contacts which must be thoroughly tightened.

The motors must be protected by appropriate circuit breakers and fuses. Connect the regulatory ground connections.

Check the direction of rotation :

 WARNING	<p>OPERATION WITHOUT THE SHAFT PROTECTOR CAN CAUSE SERIOUS PERSONAL INJURY, MAJOR PROPERTY DAMAGE OR DEATH.</p>
<p>Do not operate without guard in place.</p>	

This fundamental checking of the pump must be done without any product, with the inlet and outlet circuit open to the air, for example, to avoid any risk of an unexpected pressure rise. Start the pump empty to check the correct operation of the connections and check that the direction of rotation corresponds to installation's inlet and outlet direction.

Follow the instructions below if necessary to change the direction of rotation :

- **Three phase motor** : switch any two wires of the current supply.
- **Two phase motor** : switch the two wires of the same phase.
- **Single phase motor** : comply with the instructions of the manual supplied with the motor.

3. OPERATION

3.1 Pump storage

If the pump remains unused for more than 3 months, remove the hose or the shoes. If you do not wish to remove the hose or the shoes, operate the pump for 5 minutes once a week.

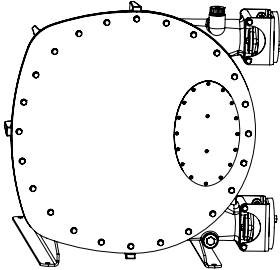

NOTE :

Check that the rotor is always in such a position that one of the shoes can be seen through the window.

For storage at temperatures below 0 °C (32 °F), specific precautions must be taken. See § LUBRICANT REPLACEMENT.

3.2 Hose storage

Hose shelf life is limited to two years from the date of purchase.

The hoses must be stored in a cool place protected from light. Exposure to ultraviolet rays accelerates deterioration of the material, thus reducing shelf life.

3.3 Hot liquids pumping

	CAUTION
	<p>THE SURFACES OF THE PUMP CAN BE AT A TEMPERATURE LIABLE TO CAUSE INJURY OR SEVERE DAMAGE.</p>
<p>Excessive temperature- can cause injury or severe damage.</p>	

When pumping products at high temperatures, take care when starting the pump for the first time, tighten the bolts to compensate for expansion effects.

If the temperature of the pumped product is greater than 60°C (140°F) : see NT 1101-Q00 SETTING HOSE COMPRESSION PUMPS HD.

3.4 Pump stopped with liquid inside

In the case where the pumping circuit is situated between isolating valves and/or has a check valve, you must bear in mind the variations in temperature that can occur, leading in particular to the expansion of the product in the circuit. In this case, provide a means of releasing the expansion volume. The use of a relief valve can suffice for this function. The opening pressure of this valve must be compatible with the pressure allowed by the parts composing the circuit. With products including particles that settle at shutdown, it is necessary to ensure that the consistency of the deposited products will not affect the start-up of the pump.

3.5 Starting the pump

	WARNING
	<p>FAILURE TO RELIEVE THE SYSTEM PRESSURE PRIOR TO PERFORMING ANY WORK ON THE PUMP OR THE INSTALLATION CAN CAUSE PERSONAL INJURY OR PROPERTY DAMAGE.</p>
<p>Hazardous pressure can cause personal injury or property damage.</p>	
	WARNING
	<p>OPERATION WITHOUT THE SHAFT PROTECTOR CAN CAUSE SERIOUS PERSONAL INJURY, MAJOR PROPERTY DAMAGE OR DEATH.</p>
<p>Do not operate without guard in place.</p>	

Before starting up the pump, always ensure that :

- Pump lubricant level is correct.
- The breathers on the rear of the pump and on the gearbox are free from any obstruction.
- The gearbox has been filled with oil and that the oil level is correct.
- All valves open on both suction and discharge lines.
- No other item is obstructing suction and discharge lines.

For use at temperatures below 0 °C (32 °F), specific precautions must be taken. See § LUBRICANT REPLACEMENT.

3.6 Stopping the pump

When stopping the pump, we recommend waiting for the pump to stop completely before closing any valve on both suction and discharge lines.

3.7 Hose burst

	WARNING
	<ul style="list-style-type: none"> • THE CASING MAY BE FILLED WITH THE PUMPED FLUID. • IF THE PUMP IS LOADED AT INTAKE OR DISCHARGE, ALL THE FLUID MAY BE EVACUATED THROUGH A HOLE IN THE HOSE IN THE PUMP BODY.
<p>Hazardous pressure can cause personal injury or property damage.</p>	

When the hose breaks, there is a risk that the lubricant may be contaminated by the pumped liquid.

3.8 Scrapping

The pump must be scrapped in compliance with applicable regulations. During this operation, particular care must be paid to the drainage stages of the pump (pumped product).

4. MAINTENANCE

	WARNING
DISCONNECT THE ELECTRICITY SUPPLY BEFORE ANY MAINTENANCE OPERATION.	
Dangerous voltage. Can cause injury and death.	

	WARNING
IF PUMPING HAZARDOUS OR TOXIC FLUIDS, THE SYSTEM MUST BE FLUSHED PRIOR TO PERFORMING ANY SERVICE OPERATION.	
Hazardous or toxic fluids can cause serious injury.	

	WARNING
HANDLING THE PUMP WITHOUT THE COVER IN PLACE MAY CAUSE BODILY HARM, SERIOUS INJURY OR EVEN DEATH.	
Do not operate without guard in place.	

	WARNING
HYDRAULIC PRESSURE MUST BE FULLY RELEASED BEFORE MAINTENANCE OPERATIONS IN ORDER TO PREVENT PERSONAL INJURY OR PROPERTY DAMAGE.	
Hazardous pressure can cause personal injury or property damage.	

Before proceeding to any maintenance operation, carefully check that :

- Pump has been drained from pumped liquid.
- There is no inside residual pressure left.
- Isolation valves are closed.
- Power supply is switched off and disconnected.

Suggested parts to order for each operation

Table below lists the minimum part list to have before each maintenance operation. Depending on their conditions, some other parts may also need replacement.

Lubricant replacement:

- Lubricant can

Hose replacement :

- Lubricant can
- 1 hose 16
- 2 gaskets 1105

Rotor assembly removal :

- Lubricant can
- 1 hose 16
- 2 gaskets 1105
- 1 cover gasket 10

Shaft seals replacement :

- Lubricant can
- 1 hose 16
- 2 gaskets 1105
- 1 cover gasket 10
- 1 seal holder 1107
- 1 gasket 127
- screws 1111 & washers 126 :
 - HD50 - HD65 3
 - HDX65 - HDX80 - HD80 - HD100 6
- 2 shaft seals 26
- 1 friction ring 27

Shoes replacement :

- Lubricant can
- 2 shoes 5
- 2 to 6 removable shims 4
- 1 window seal 46

Pump pressure setting :

- Lubricant can
- 2 to 6 removable shims 4
- 1 window seal 46

Tightening torques

Part No	Designation	Torque (Nm)			
		HD50 HD65	HDX65 HDX80	HD80	HD100
19	Rotor hub	41	-	-	-
28	Shoe screw	244	244	244	355
33	Cover screw	50	97	126	464
37	Window screw	3	6	6	6
39	Support / pump body screw	126	126	244	613
42	Pump body / gear reducer stud nut	69	-	-	-
48	Bracket screw	50	50	126	244
134	Lock washer screw	-	40	70	70
1106	Pressing gland screw	51 ±8	51 ±8	100 ±15	195 ±30
1109	Pump body / gear reducer screw	-	80	127	127
1111	Shaft seal holder / pump body screw	19	15	15	15

4. MAINTENANCE (continued)

4.1 Lubricant replacement

The hose is lubricated with a special mixture. ABAQUE lubricant is recommended to lengthen the service life of the hose.

It is recommended to change the lubricant :

- when replacing the hose.
- after 1500 hours of operation

The minimum working or storage temperature for the pump lubricant is 0°C (32°F).

For use / storage at lower ambient temperatures, it is necessary to add ethylene glycol to the ABAQUE lubricant. To maintain optimum lubrication, the volume of ethylene glycol should remain between 4% and 6% of the total volume of lubricant, and the total quantity of lubricant present in the pump must be in compliance with the value specified above. In any case, the ambient temperature should never be lower than -20°C (-4°F).

DO NOT USE ANY VEGETAL, MINERAL OR SYNTHETIC OIL AS IT WOULD RAPIDLY DESTROY THE HOSE.

Draining

Put a drain tray below plug 23.

Unscrew plug 23 and wait for complete lubricant draining. Clean and degrease plug 23.

Wrap it with PTFE tape.

Screw plug 23 in the pump body.

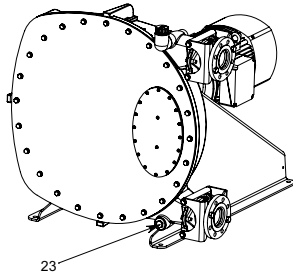

Lubricant filling

Remove breather 11.

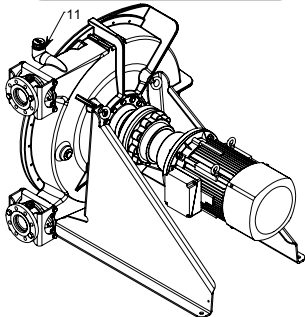

Fill the pump with corresponding volume of lubricant :

- HD50 - HD65..... 10 l. (2,64 gal.)
- HDX65 - HDX80 20 l. (5,28 gal.)
- HD80 40 l. (10,56 gal.)
- HD100 60 l. (15,84 gal.).

Put back breather 11.

4.2 Hose replacement

Hose removal

Drain lubricant (see § LUBRICANT REPLACEMENT). Disconnect suction and discharge ports.

Disconnect power supply.

Make sure there is enough space beside pump to let hose coming out. See § PUMP LOCATION.

Unscrew and remove pressing gland screws 1106 and their washers 1108.

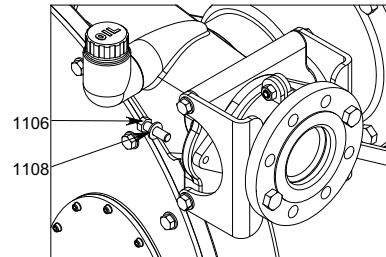

Loosen and remove hose clamp 9.

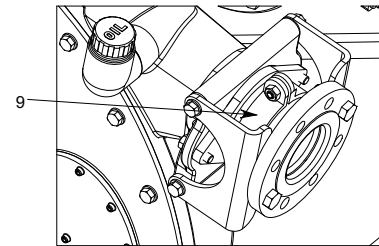

Remove insert 12 and flange 47.

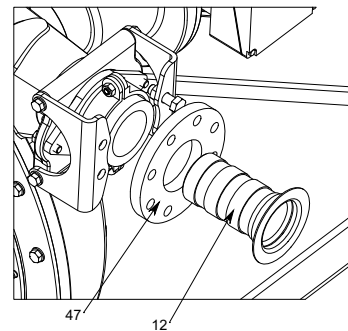

Remove the four screws 48 and washers 49. Remove the two brackets 18.

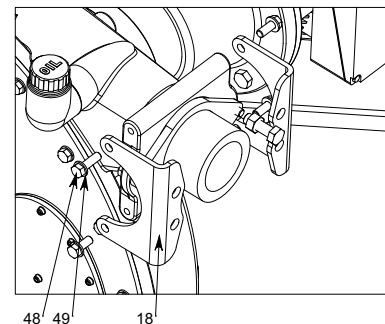

4. MAINTENANCE (continued)

Remove pressing gland 1104 and gasket 1105.

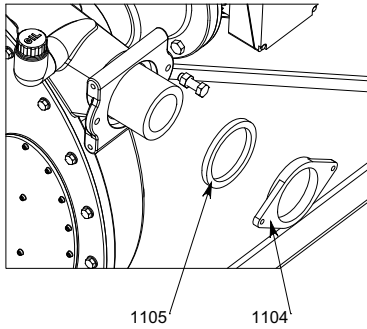

Put a drain tray under bottom port and repeat the same operations on bottom port.

	WARNING
	<p>THE HOSE CAN COME OUT OF PUMP VIOLENTLY. BE SURE NO ONE IS IN FRONT OF PUMP PORTS.</p>
<p>Hazardous machinery can cause severe personal injury or property damage.</p>	

Connect power supply.

Rotate the pump intermittently until the hose 16 is completely outside pump body.

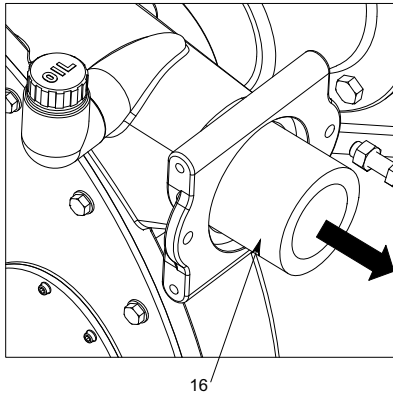

	WARNING
	<p>DISCONNECT THE ELECTRICITY SUPPLY BEFORE ANY MAINTENANCE OPERATION.</p>
<p>Dangerous voltage. Can cause injury and death.</p>	

Disconnect power supply.

Hose refitting

	WARNING
	<p>NEVER INSERT THE HOSE OR RUN THE PUMP WITHOUT ITS COVER AND ITS WINDOW IN PLACE.</p>
<p>Do not operate without guard in place.</p>	

Clean the hose 16 to eliminate any particles that may have adhered to it (gravel, etc.).

Generously coat the hose with lubricant.

Connect power supply.

Insert one end of the hose 16 in the suction port.

If pump rotates clockwise, suction is on the bottom port :

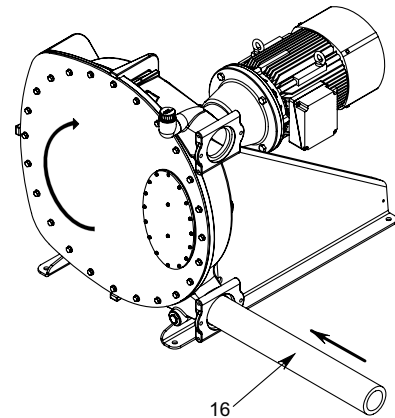

If pump rotates anti-clockwise, suction is on the top port :

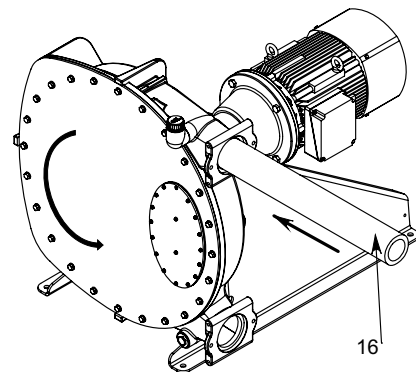

4. MAINTENANCE (continued)

Rotate the pump intermittently until the hose 16 is completely inserted in the body and show equal lengths outside the body on both ports :

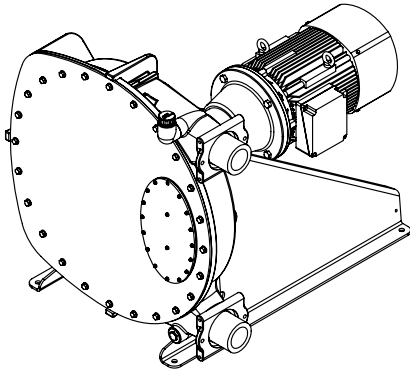

 WARNING	DISCONNECT THE ELECTRICITY SUPPLY BEFORE ANY MAINTENANCE OPERATION.
 Dangerous voltage. Can cause injury and death.	

Disconnect power supply.

On one port :

1. Place gasket 1105 and pressing gland 1104.

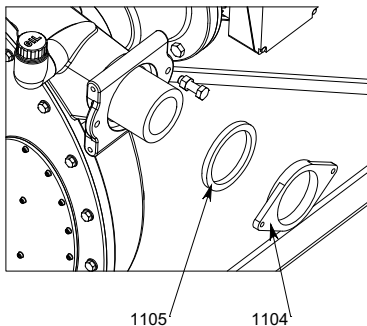

2. Place the two brackets 18. Screw and tighten the four screws 48 with their washers 49.

Tightening torque :

HD50 - HD65	50 Nm
HDX65 - HDX80 ...	50 Nm
HD80	126 Nm
HD100	244 Nm

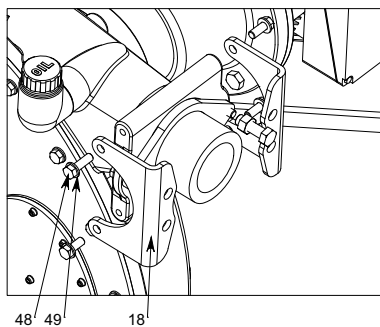

3. Place flange 47 and put insert 12 after coating its outside with pump lubricant.

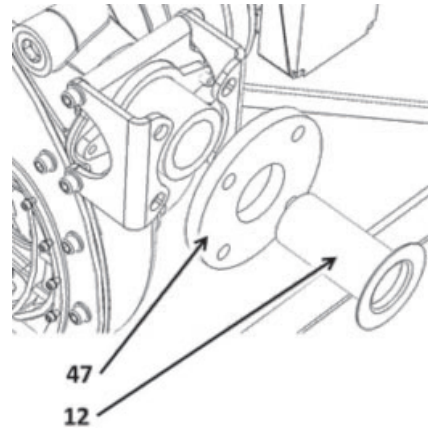

4. Fit and tighten hose clamp 9.

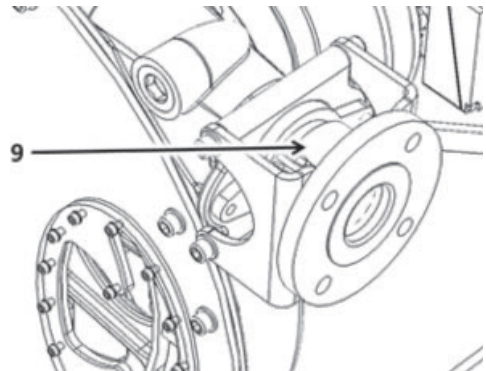

5. Fit screws 1106 with their washers and tighten them.

Tightening torque :

HD50 - HD65	51 ± 8 Nm
HDX65 - HDX80 ...	51 ± 8 Nm
HD80	100 ± 15 Nm
HD100	195 ± 30 Nm

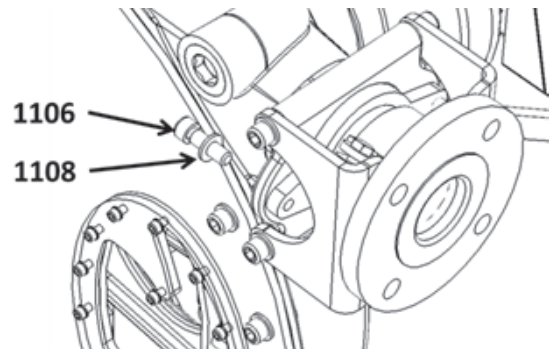

Repeat operations 1 to 5 on the other port.

Fill the pump with lubricant (see § LUBRICANT REPLACEMENT).

Connect power supply.

Rotate pump and check that there is no visible axial movement of the hose or lubricant leakage.

4. MAINTENANCE (continued)

4.3 Rotor assembly removal

Disassembly and reassembly of the rotor 3 are required when :

- replacing the shaft seals 26.
- performing a complete overhaul.
- disassembling or replacing the gear reducer.

Rotor assembly removal

Drain lubricant (see § LUBRICANT REPLACEMENT) and remove hose (see § HOSE REPLACEMENT).

Loosen screws 33 and 33A (HDX65 HDX80) with their washers 34.

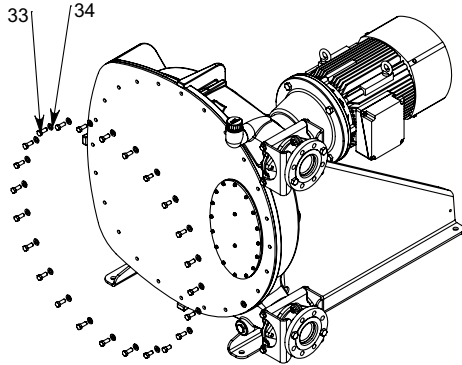

	WARNING
	BE CAREFUL WITH THE WEIGHT OF THE COVER WHEN ALL SCREWS ARE REMOVED.
<p>The weight of the parts can be dangerous and may provoke bodily injuries or material damages.</p>	

Remove cover 2 with its gasket 10.

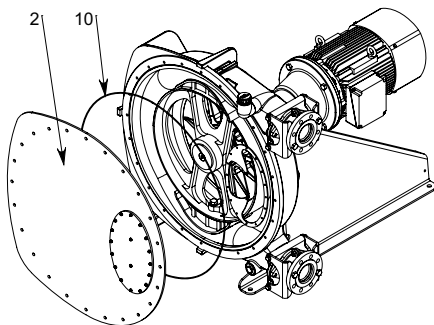

On the rotor 3, loosen screws 28 and remove them with washers 29. Remove shoes 5 and shims 4. Note shims type and quantity to restore identical shimming when reassembling the pump.

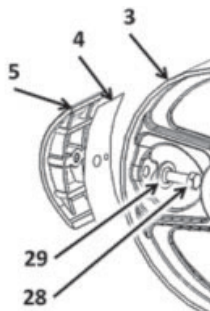

HD50 HD65 :

On rotor hub 19, loosen all screws without removing them. Put 5 screws in the extraction threading to loosen the hub.

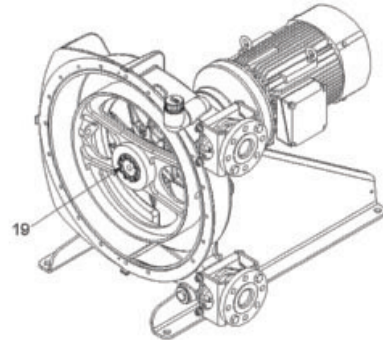

HDX65 HDX80 HD80 HD100 :

Loosen screw 134 and remove lock washer 135.

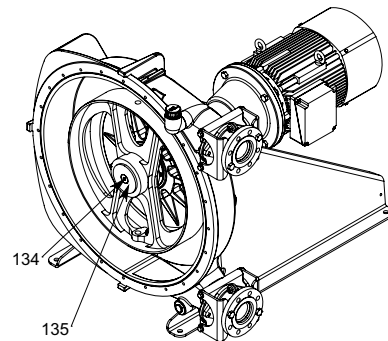

Pull out the rotor 3.

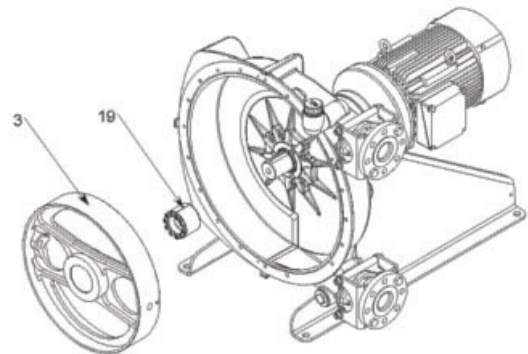

	WARNING
	BE CAREFUL WITH THE WEIGHT OF THE ROTOR.
<p>The weight of the parts can be dangerous and may provoke bodily injuries or material damages.</p>	

4. MAINTENANCE (continued)

Rotor assembly refitting

HD50 HD65 :

Place hub 19 and rotor 3 on gear reducer shaft.

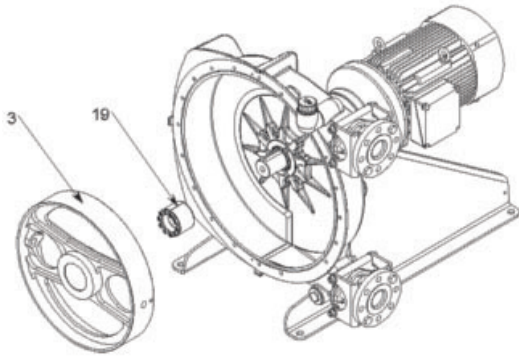

HDX65 HDX80 HD80 HD100 :

Place rotor 3 on gear reducer shaft.

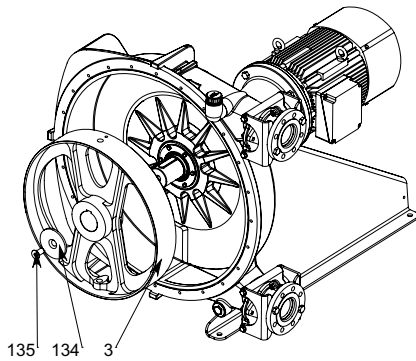

Position rotor 3 to have distance B between rotor outer edge and casing 1 back wall.

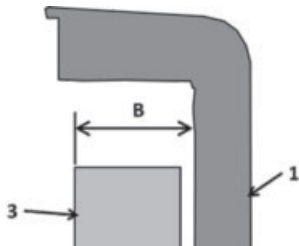

Distance B :

HD50 - HD65.....	102 mm ±2 mm (4,016 in. +0,079 in.)
HDX65 - HDX80	134 mm ±2 mm (5,276 in. +0,079 in.)
HD80	145 mm ±2 mm (5,709 in. +0,079 in.)
HD100	170 mm ±2 mm (6,693 in. +0,079 in.)

Place lock washer 135 (HDX65 HDX80 HD80 HD100).

Progressively tighten screws on hub 19 (HD50 HD65), screw 134 (HDX65 HDX80 HD80 HD100), keeping distance B constant.

Tightening torque : HD50 - HD65 **41 Nm**
HDX65 - HDX80 **40 Nm**
HD80 - HD100 **70 Nm**

On rotor 3, place shoes 5 and shims 4. Make sure shims type and quantity are identical to combination found when taking pump apart. Screw and tighten screws 28 with their washers 29.

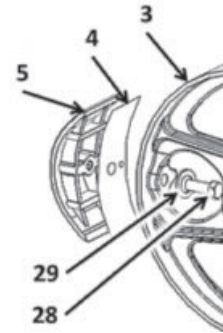

Screw and tighten screws 28 with their washers 29, carefully checking shoes 5 alignment with rotor 3.

Tightening torque 244 Nm (HD100 : 355 Nm)

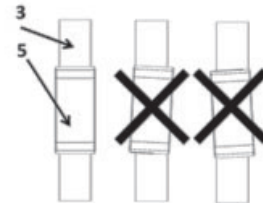

Rotate rotor and shoes assembly slowly and carefully check that no part comes in friction against pump body.

Putting a bar on pump body, also check that rotor and shoes assembly does not come in contact with it.

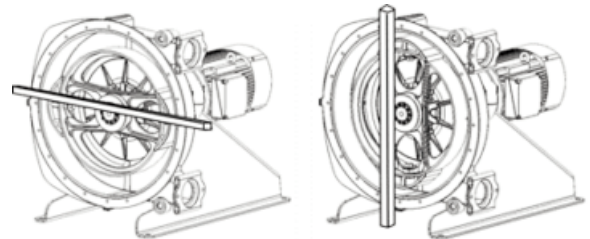

Put cover gasket 10 in pump body, starting at the top. Make sure that the two ends of gasket are firmly in contact.

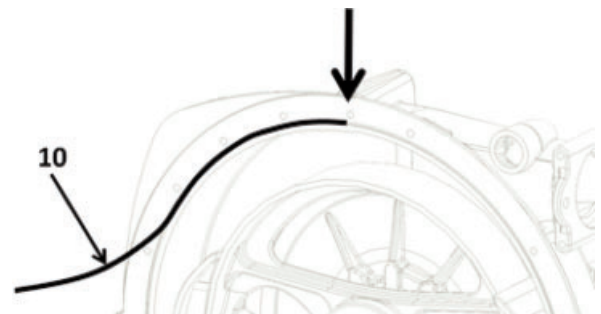

4. MAINTENANCE (continued)

Incorrect mounting : risk of leak and body vacuuming impossible.

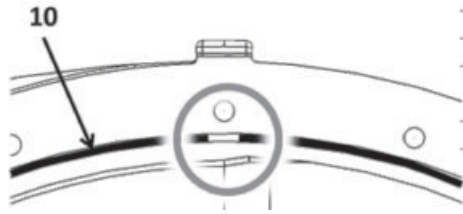

Correct mounting :

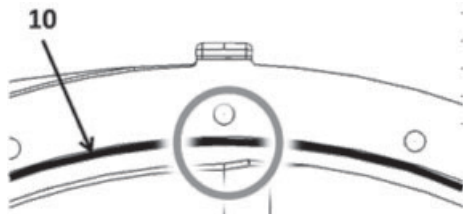

	WARNING
	BE CAREFUL WITH THE WEIGHT OF THE COVER WHEN ALL SCREWS ARE REMOVED.
<p>The weight of the parts can be dangerous and may provoke bodily injuries or material damages.</p>	

Place cover 2 bottom on body bottom support leg and push up cover 2 top in position.

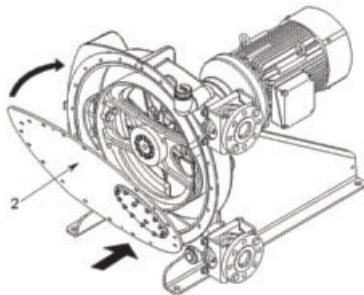

Screw and tighten screws 33 and their washers 34, starting by top ones to secure cover assembly.

Tightening torque :

HD50 - HD65	50 Nm
HDX65 - HDX80	97 Nm
HD80	126 Nm
HD100	464 Nm

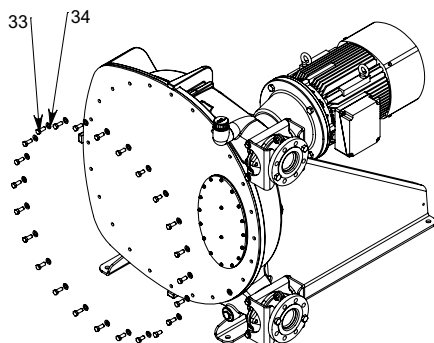

Fit hose in (see § HOSE REPLACEMENT) and fill the pump with lubricant (see § LUBRICANT REPLACEMENT).

4.4 Shaft seals replacement

Drain lubricant (see § LUBRICANT REPLACEMENT), remove hose (see § HOSE REPLACEMENT) and remove rotor (see § ROTOR ASSEMBLY REMOVAL).

Loosen and remove seal holder screws 1111 and their copper washers 126. Remove seal holder 1107 and its gasket 127. Extract shaft seals 26 from seal holder.

HD50 HD65 :

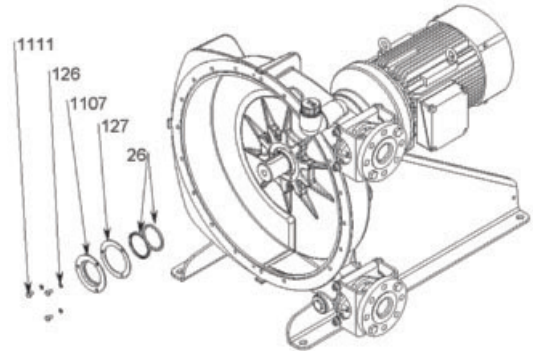

HDX65 HDX80 HD80 HD100 :

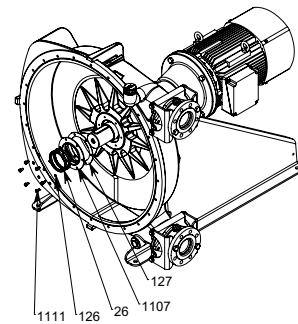

If friction ring on gear reducer needs replacement :



	WARNING
	BE CAREFUL WITH THE WEIGHT OF THE PUMP.
<p>The weight of the parts can be dangerous and may provoke bodily injuries or material damages.</p>	

Using appropriate lifting device, put pump with reducer and motor in vertical, up position.

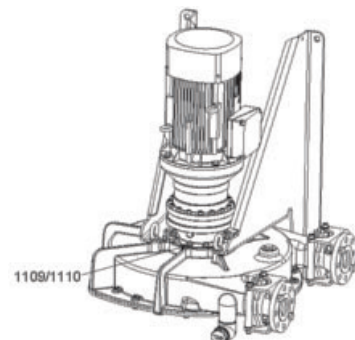
Loosen and remove screws 1109 and their washers 1110.



4. MAINTENANCE (continued)

	WARNING
	BE CAREFUL WITH THE WEIGHT OF MOTOR AND REDUCER ASSEMBLY.
<p>The weight of the parts can be dangerous and may provoke bodily injuries or material damages.</p>	

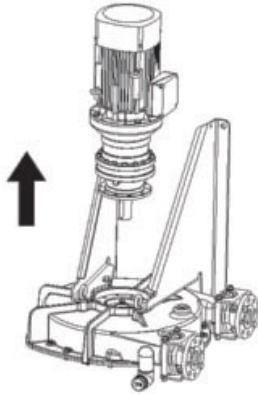

Using appropriate lifting device, lift motor and reducer assembly.

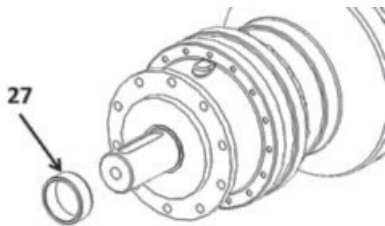

Using a mallet and a chisel, break and remove friction ring 27.



Heat new friction ring at $110 \pm 10^\circ\text{C}$ / $230 \pm 50^\circ\text{F}$.

	CAUTION
	BE CAREFUL WITH THE VERY HIGH TEMPERATURE OF FRICTION RING. USE APPROPRIATE HANDLING DEVICES.
<p>Excessive temperature can cause injury or severe damage.</p>	

Put high temperature sealant Loctite* 648® or equivalent on reducer shaft from shaft shoulder and on a length corresponding to friction ring width.

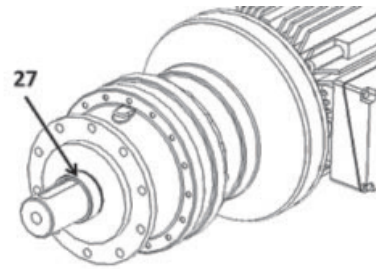

Put new friction ring on shaft, pushing it against shaft shoulder.



Let friction ring cool down before carrying on reassembly.

HD80 HD100 :

Sealant : Fill the groove section under ring 27 with TEROSON MS 935 sealant. Orientate the groove upward and let sealant polymerize during 1 day.

	WARNING
	BE CAREFUL WITH THE WEIGHT OF MOTOR AND REDUCER ASSEMBLY.
<p>The weight of the parts can be dangerous and may provoke bodily injuries or material damages.</p>	

Using appropriate lifting device, put back motor + reducer assembly, checking correct motor connection box position.

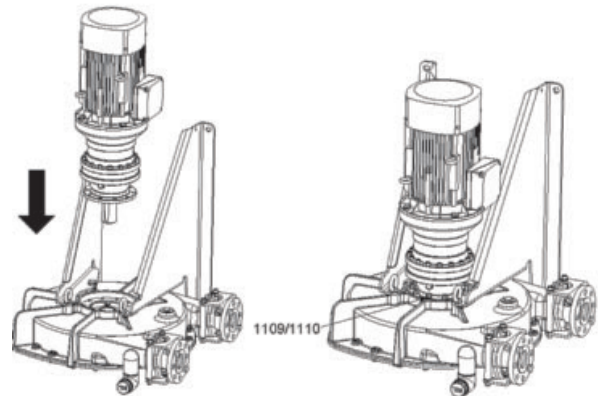



Put back studs 41 with their nuts 42 (HD50 - HD65) or screws 1109 with their washers 1110 (HDX65 - HDX80 - HD80) and tighten them.

Tightening torque :

HD50 - HD65	69 Nm
HDX65 - HDX80	80 Nm
HD80 - HD100.....	127 Nm

* Loctite® is a registered trademark.

4. MAINTENANCE (continued)

 WARNING	BE CAREFUL WITH THE WEIGHT OF THE PUMP.
	
<p>The weight of the parts can be dangerous and may provoke bodily injuries or material damages.</p>	

Using appropriate lifting device, put back pump in normal position.

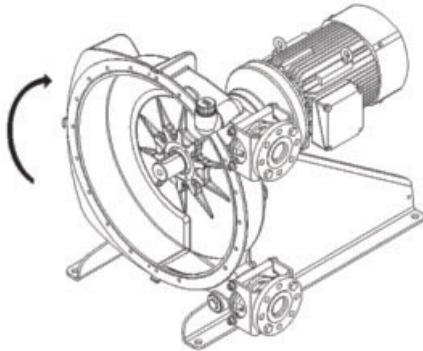

Assemble shaft seals 26 in seal holder 1107.

Make sure the shaft seals are in the right direction.

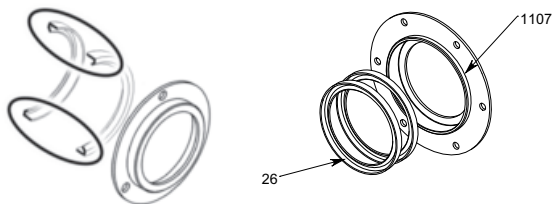

HD50 HD65

HDX65 HDX80 HD80 HD100

Place in pump body, gasket 127 and seal holder 1107. Put copper washers 126 on screws 1111. Screw and tighten screws 1111.

Tightening torque :

HD50 - HD65 **19 Nm**

HDX65 - HDX80 - HD80 - HD100 **15 Nm**

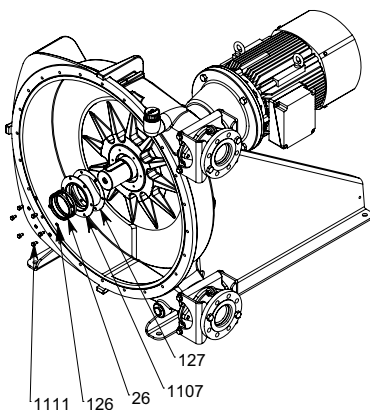

Refit rotor in the pump (see § ROTOR REMOVAL), refit hose (see § HOSE REPLACEMENT) and fill the pump with lubricant (see § LUBRICANT REPLACEMENT).

4.5 Shoes replacement

This operation can also be performed during rotor removal (see § ROTOR REMOVAL).

Removing shoes

Drain lubricant (see § LUBRICANT REPLACEMENT).

Rotate pump until a shoe is facing the windows.

Loosen and remove screws 37 and their washer 38.

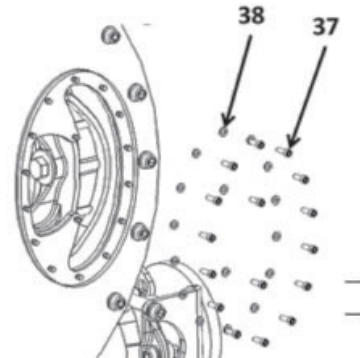

Remove window 15 and its seal 46.

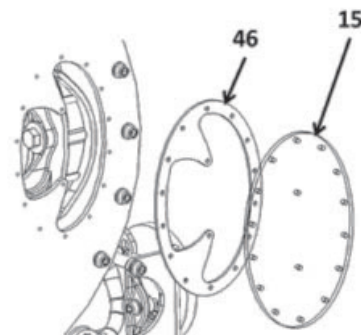

Holding the shoe 5 with a flat clip, loosen and remove screw 28 and its washer 29.

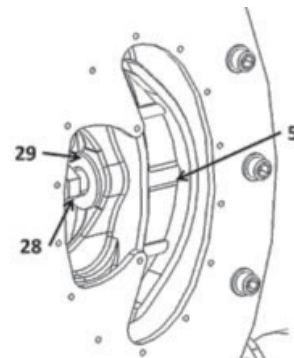

Pull the shoe 5 and its shim(s) 4, first in the radial direction to let pin come out of the rotor then out of the pump.

Note shims type and quantity to restore identical shimming when refitting the shoe.

4. MAINTENANCE (continued)

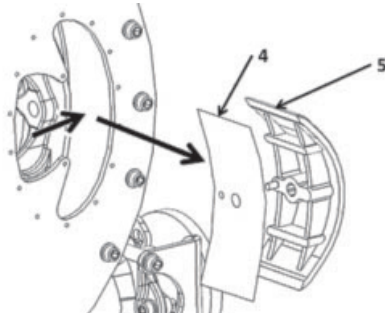

Repeat the same operations on the other shoe.

Shoes refitting

Place shoes 5 and shims 4. Make sure shims type and quantity are identical to combination found when removing shoes. Screw and tighten screws 28 with their washers 29.
Tightening torque 244 Nm (HD100 : 355 Nm)

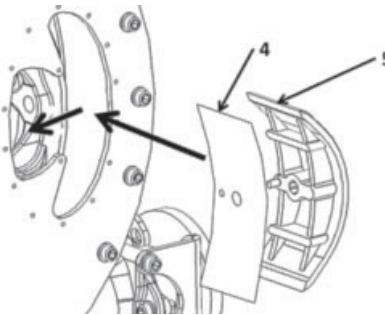

Check window seal 46 and replace it if necessary.

Place window 15 and its seal 46.

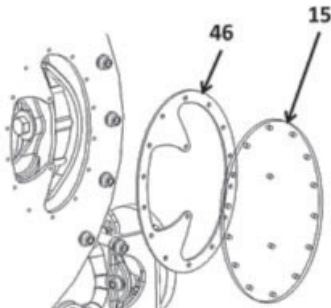

Screw and tighten screws 37 and their washers 38.

Tightening torque:

HD50 - HD65	3 Nm
HDX65 - HDX80 - HD80 - HD100	6 Nm

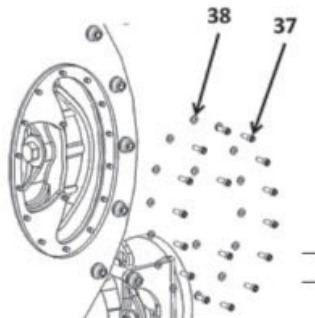

Repeat the same operations on the other shoe.

Fill the pump with lubricant (see § LUBRICANT REPLACEMENT).

4.6 Pump pressure setting

Suitable shimming of the shoes lengthens the service life of the hose.

SERVICE PRESSURE SPECIFIED AT ORDER

If the service pressure has been specified at order, the pump is shimmed in the factory to allow pump running at specified service pressure. No additional shimming is needed.

SERVICE PRESSURE NOT SPECIFIED AT ORDER OR MODIFICATION OF THE OPERATING PRESSURE OR THE TEMPERATURE OF THE PUMPED PRODUCT

If the service pressure has not been specified at order, the pump is pre-configured by the manufacturer for a service pressure up to 5 bar (72,5 psi).

For higher pressure value, one or more removable shims must be placed under the shoes. Similarly, for using the equipment at a lower service pressure, one or more removable shims should be removed from below the shoes.

REMINDER

Before modifying the shimming of the pump, check that the equipment (motor and pump) is compatible with the new operating conditions.

See NT 1101-Q00 SETTING HOSE COMPRESSION PUMPS HD.

5. TROUBLESHOOTING

PROBLEM	POSSIBLE CAUSE	SOLUTION
THE PUMP DOES NOT START	Electric power supply failure.	<p>Check the connections :</p> <ul style="list-style-type: none"> • There must be 3 phases. • The connections are suitable for the voltage (delta-star). • If possible, check the parameters for the different motor frequencies (starting torque, power input...).
	<p>When the pump has not been used for a long period of time, one shoe can have been kept outside the lubricant.</p> <p>As it has not been lubricated, it causes a lot of resistance on start up.</p>	<p>Operate the pump intermittently to try to free the rotor but do not be too insistent to prevent the reduction gear from being damaged.</p> <p>If the rotor remains stuck, contact your local dealer for instructions.</p>
	Sediments or other substances have built up inside the hose and are blocking the pump.	<p>Reverse the pump rotation direction or disassemble the hose.</p> <p>If the rotor remains stuck, contact your local dealer for instructions.</p>
ABNORMALLY LOW FLOW	The inlet or discharge valve is partially closed.	Open the inlet or discharge valve.
	Air is entering the inlet piping.	Check the inlet line.
	The pumped liquid is too viscous. Significant pressure drop at inlet.	Check the inlet line.
	The pump hose is damaged.	Replace the hose.
ABNORMALLY HIGH TEMPERATURE	The lubricant is not suitable.	Empty the pump body and replace the lubricant with one that is recommended by ABAQUE.
	The lubricant is dirty or too old.	Empty the pump body and replace the lubricant with a new ABAQUE lubricant.
	Temperature of the pumped fluid is too high.	Check the maximum fluid temperature allowed for the hose material.
	Pump speed too high.	Reduce speed.
ABNORMALLY SHORT HOSE LIFE SPAN	Lubricant is not suitable.	Empty the pump body and replace the lubricant with one that is recommended by ABAQUE.
	Chemical incompatibility between the hose and the pumped fluid.	Check the compatibility of the hose with the fluid and replace the hose with another one made of suitable material.
	Temperature of pumped fluid too high.	Check the maximum temperature permitted for the hose.
	The discharge pressure is too high.	Check the maximum pressure allowed for the pump. Reduce pressure drop at discharge.
	Pump speed is too high.	Reduce speed.
THE HOSE IS PULLED INTO THE PUMP BODY AT INLET	The pumped fluid contains impurities or sediments.	Reverse the pump rotation direction and use the upper port for inlet.
	Pressing gland is not sufficiently tightened.	Retighten the pressing gland.