

SAFETY MANUAL— READ FIRST!

IMPORTANT: READ THESE WARNINGS AND SAFETY PRECAUTIONS PRIOR TO INSTALLATION OR OPERATION. FAILURE TO COMPLY WITH THESE INSTRUCTIONS COULD RESULT IN PERSONAL INJURY AND OR PROPERTY DAMAGE. RETAIN THESE INSTRUCTIONS FOR FUTURE REFERENCE.

⚠ WARNING Pump, valves and all containers must be properly grounded prior to handling flammable fluids and/or whenever static electricity is a hazard.

⚠ WARNING Prior to servicing the pump, ensure that the air and fluid lines are closed and disconnected. While wearing personal protective equipment, flush, drain and process liquid from the pump in a safe manner.

⚠ CAUTION Do not connect a compressed air source to the exhaust port of the pump.

⚠ CAUTION Ensure that the muffler is properly installed prior to pump operation.

⚠ CAUTION Do not lubricate air supply.

⚠ CAUTION When selecting pump materials, be aware of the following temperature limitations:

Buna-N (Nitrile):	10°F to 180°F (-12C to 82C)
Geolast®:	10°F to 180°F (-12C to 82C)
EPDM:	-40°F to 280°F (-40C to 138C)
Santoprene®:	-40°F to 225°F (-40C to 107C)
Viton® (FKM):	-40°F to 350°F (-40C to 177C)
PTFE:	40°F to 220°F (4C to 104C)
Polyethylene:	32°F to 158°F (0C to 70C)
Polypropylene:	32°F to 180°F (0C to 82C)
PVDF:	0°F to 250°F (-18C to 181C)
Nylon:	0°F to 200°F (-18C to 93C)

Temperature limits are solely based upon mechanical stress and certain chemicals will reduce the maximum operating temperature. Consult a chemical resistance guide for chemical compatibility and a more precise safe temperature limit. Always use minimum air pressure when pumping at elevated temperatures.

⚠ WARNING = Hazards or unsafe practices which could result in severe personal injury, death or substantial property damage

⚠ CAUTION = Hazards or unsafe practices which could result in minor personal injury, product or property damage.

⚠ CAUTION Do not exceed 120 psig (8.3 bar) air-inlet pressure.

⚠ CAUTION Ensure all wetted components are chemically compatible with the process fluid and the cleaning fluid.

⚠ CAUTION Ensure pump is thoroughly cleaned and flushed prior to installation into a process line.

⚠ CAUTION Always wear Personal Protective Equipment (PPE) when operating pump.

⚠ CAUTION Close and disconnect all compressed air and bleed all air from the pump prior to service. Remove all process fluid in a safe manner prior to service.

⚠ CAUTION Blow out all compressed air lines in order to remove any debris, prior to pump installation.

⚠ CAUTION Ensure air exhaust is piped to atmosphere prior to a submerged installation.

⚠ CAUTION Ensure all hardware is set to correct torque values prior to operation.

⚠ CAUTION Ensure that the selected pump model number is made from the correct material and matches that which was ordered.

INSTALLATION

Notice: Re-torque fasteners prior to use. Refer to torque requirements listed in maintenance manual and attached to pump.

1. A lube-free, clean, dry compressed air source (or any nonflammable, compressed gas) is recommended. Use a filter that is capable of filtering out particles larger than 50 microns.
2. All pumps should be mounted in an upright position with the exception of the 1/4" models which may be rotated 360° to suit the application.
3. When particles exceed the maximum particle specification of the pump or are sharp enough to cut elastomers install a particle fluid filter on the fluid suction line.
4. Fluid suction lines and air exhaust lines should never be smaller than specified pipe size of the pump.
5. Apply PTFE (Teflon®) tape to threads upon assembly to prevent leakage.
6. Never use pipe dope on air line connections.
7. Never use collapsible tube on fluid inlet.
8. Do not exceed 10 ft-lbs of torque on plastic pipe threads.
9. If changing to a different application reconfirm compatibility of fluid.

SUBMERGED APPLICATIONS

1. Fluid must be compatible with fasteners and intermediate material.
2. Pipe exhaust above the level of the fluid.

HIGH VISCOSITY APPLICATIONS

1. Position the pump close to or below the level of the fluid source
2. Suction lines should be increased in size - up to three times the size of the inlet manifold. Dual manifolds may be used when available.
3. Start the pump slowly using a valve on the air line.

LOW TEMPERATURE AND UV EXPOSURE

1. Polypropylene tends to embrittle at freezing temperatures. Pump must be insulated or heated, otherwise use pumps with different materials of construction.
2. If excessive icing occurs at the pump exhaust, air source must be dried using mechanical means or through the introduction of ethyl alcohol in the air line.
3. UV rays will damage polypropylene pumps, either shroud the pumps from UV rays or use pumps with UV stabilized materials.

GENERAL MAINTENANCE

1. Check periodically for product or air leakage. Tighten any joint where leakage is occurring.
2. When pumping hazardous or toxic materials, diaphragms should be replaced at regularly scheduled intervals based upon pump usage.
3. In freezing temperatures, the pump must be completely drained when idle.
4. When pumping highly abrasive fluids reduce discharge flow rate or reduce air pressure to prolong diaphragm life.
5. If you are pumping a material that will settle or compact, the pump must be flushed before shut down.

TROUBLE SHOOTING

AIR IS APPLIED TO PUMP BUT PUMP IS NOT STARTING

1. Clean filters and debris from all fluid lines.
2. Make sure all valves on fluid lines are open.
3. Inspect diaphragms for rupture.
4. Air pressure must not be below 20 psi (1,3 bar).

PUMP IS PUMPING BUT NOT PRIMING

1. Check all suction line connections for leakage.
2. Inspect check valves for wear or debris.
3. Suction lift specifications may be exceeded.
4. If fluid is viscous use larger suction lines.

LEAKAGE

1. Retorque all fasteners to specified torque requirements.
2. Replace o-rings.
3. Inspect diaphragms for rupture.

LOW FLOW RATE

1. Confirm air pressure and air capacity at the air valve as required.
2. Check for leaks in suction line or obstructions in lines.
3. If fluid is viscous use larger lines.
4. Viscosity of fluids may have increased if temperature is lower.

AIR IN DISCHARGE LINES

1. Check for leaks in suction lines.
2. Inspect diaphragms for rupture.

ERRATIC CYCLING

1. Inspect check valve seats for debris.
2. Inspect fluid lines for debris.
3. Automatic valves must be properly functioning.
4. Viscosity of product may be changing.

PREMATURE DESTRUCTION OF WETTED COMPONENTS

1. If fluid is abrasive, slow down pump or increase size of pump.
2. Filter fluid for sharp objects.
3. Make sure fluid is compatible with wetted materials.

1/2" PERFORMANCE PLUS METALLIC MAINTENANCE MANUAL

CHECK VALVE AND O-RING MAINTENANCE

1. Flush and neutralize the pump to be certain all corrosives or hazardous materials are removed prior to any maintenance. This procedure should always be followed when returning pumps for factory service also.
2. Remove bolts (19) in both the discharge and suction manifolds. Suction check valve seats and check balls (26, 27) are located inside of the bottom of the outer chamber (28). Gently remove and inspect for excessive wear, pitting or other signs of degradation. Inspect valve seat and manifold o-rings (38). Replace if necessary. Discharge check valves are located inside of the bottom of the discharge manifold (32). Repeat procedure for inspection of discharge check valves and o-rings.
3. When re-assembling, the check ball should fit within the ball cavity of the chamber and discharge manifold. Press fit the valve seats into position with the curved portion facing the ball. Lightly tighten fasteners. Tighten all external fasteners to final torque requirement after pump is completely assembled.

NOTE: When using pumps built with PTFE o-rings always replace with new PTFE o-rings, since the original o-rings may not reseal the pump.

DIAPHRAGM AND PILOT SLEEVE ASSEMBLY MAINTENANCE

4. To inspect diaphragms remove nuts (18) from bolts (16) from the outer pumping chambers (28). If replacement is necessary due to abrasion or rupture, unscrew the outer diaphragm plates (29). Models that are built with PTFE elastomers will have a PTFE overlay (30) that faces the outer pumping chamber and a back-up diaphragm (31) on the air side of pump. Pumps without PTFE will contain only the back-up diaphragms.
5. If there has been a diaphragm rupture and corrosive or viscous fluid has entered the air side of pump the complete air system should be inspected. After removing diaphragms and inner diaphragm plate (33), the pilot sleeve assembly (14, 40, 42, 45-47) and diaphragm rod assembly (13, 15) may be removed by removing the retaining plates (41) and pushing the entire unit out through the bore in the intermediate (34). Diaphragm rod assembly must be unscrewed to remove pilot sleeve.

NOTE: To aid in reassembly use a non-synthetic, petroleum based lubricating grease without EP additives. Carleton-Stuart MagnaLube G is recommended.

6. Clean or replace any components that have excessive wear, dirt build-up, or chemical attack. Lube all components prior to reassembling. Reassemble pilot sleeve spacers, o-rings and lip seals (40) within bore of intermediate. Make sure that the open sides of the lip seals are facing outward toward the diaphragms. Also make sure that the end spacers (14) are at the end on either side of the pilot sleeve assembly and all inner spacers (47) are separated by o-rings. Next, carefully insert the diaphragm rod assembly with pilot sleeve inside the assembly in the bore. Reattach retaining plates. Do not over tighten self-tapping screws (24).
7. Take one diaphragm and invert (reverse the natural bow of the material) and with the curved side of the inner diaphragm plate facing the diaphragm assemble onto outer diaphragm plate stud and then screw assembly into

diaphragm rod. Push diaphragm rod to the opposite side of the intermediate and add the opposite diaphragm assembly. **Tighten the outer diaphragm plates to 70 in-lbs (7,91 NM) of torque.** After tightening, reverse the inverted diaphragm back to its original state, allowing the outer bead to seat in the groove of the intermediate.

NOTE: Inverting the first diaphragm aids reassembly.

8. Position outer diaphragm chambers onto intermediate making sure that witness lines are matching.
NOTE: If air valve has been removed, proper orientation of air system with fluid chambers must be observed. The bottom of the intermediate has the smaller hook shaped air passage slot on the air valve mounting face, and the outer chamber check ball cavity should be pointing downward.
9. Tighten all external fasteners to final torque requirement after pump is completely assembled.
10. Position the manifolds making sure of the proper orientation in relation to the air valve for your application. Also make sure that the manifold o-rings do not shift from their grooves during reassembly. Tighten all external fasteners to final torque requirement after pump is completely assembled.

EXTERNAL FASTENER TORQUE REQUIREMENTS

NOTE: When reassembling, loosely tighten all external fasteners adjusting and aligning and gradually, in an alternating fashion, tighten to torque requirements listed below.

AIR VALVE CAP SCREWS 40 in-lbs (4,52 NM)

MANIFOLD BOLTS, 90-100 in-lbs (10,17-11,3 NM)

OUTER CHAMBER CAP SCREWS, 75-85 in-lbs (8,48-9,61 NM)

AIR VALVE MAINTENANCE

11. To evaluate air valve components, remove the four cap screws (11), washers, (25, 10) and nuts (17) from the air valve body (7). The shuttle plate (5) and shuttle (6) can be inspected by removing them from their location in the slot in the back of the air valve. Inspect for scratches or surface irregularities. Replace if necessary. Remove the plug (1) at the bottom of the air valve. Next, push the air valve spool (2) out of the air valve body. Gently reach in and pull lip seals (43) out of inside bore of the air valve body. Check for cracks, splitting or scratches. Clean components if replacement is not necessary. Inspect plug o-ring (44) for any damage, replace if necessary and reposition o-ring into groove in air valve body.
NOTE: Make sure that the open sides of the two lip seals face each other when reassembling air valve. Lube all components with suggested maintenance grease as an aid in reassembly.
12. Reinsert air valve spool inside of air valve body. Place shuttle on middle rib of air valve spool through the square slot in back of air valve. Lubricate side of plate that faces the shuttle and reposition valve plate over shuttle. Press the valve plug into air valve body, chamfered end first.
13. Check that gasket (4) is not cracked. If damaged replace.
14. After gasket is pressed back into position align air valve onto intermediate and reinsert the four cap screws with lock washer and flat washers. Apply 40 in-lbs (4,52 NM) of torque to fasteners.

SPECIFICATIONS

CAPACITY:

Adjustable 0-17 GPM (64,6 LPM)

MAXIMUM TEMP:

Metallic models – 200°F (93°C)

MAXIMUM AIR PRESSURE:

120 psi (8,2 bar)

MINIMUM AIR PRESSURE:

20 psi (1,3 bar)

DRY LIFT:

Models with PTFE balls – 10 feet (3 meters)

Other models – 15 feet (4,5 meters)

WEIGHT:

Aluminum models – 10 pounds (4,5 kg)

Stainless Steel models – 19 pounds (8,6 kg)

MAXIMUM SOLIDS:

1/8" (3,2 mm) Ball Check Valve

AIR SUPPLY:

Inlet – 1/4" NPT Female (BSP compatible)

Outlet – 3/8" NPT Female

FLUID INLET/DISCHARGE:

1/2" NPS Female (NPT or BSP compatible)

DIMENSIONS

Dimensions in inches and (mm)

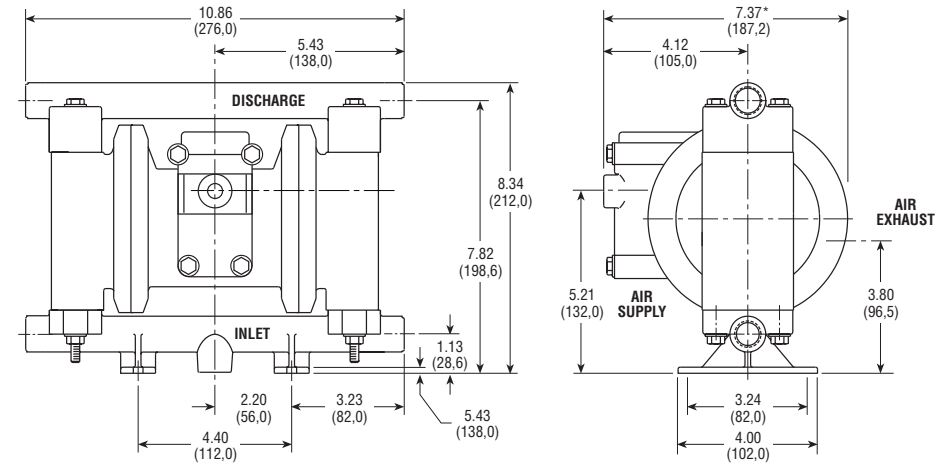

PERFORMANCE CURVE

(Based on water-flooded suction)

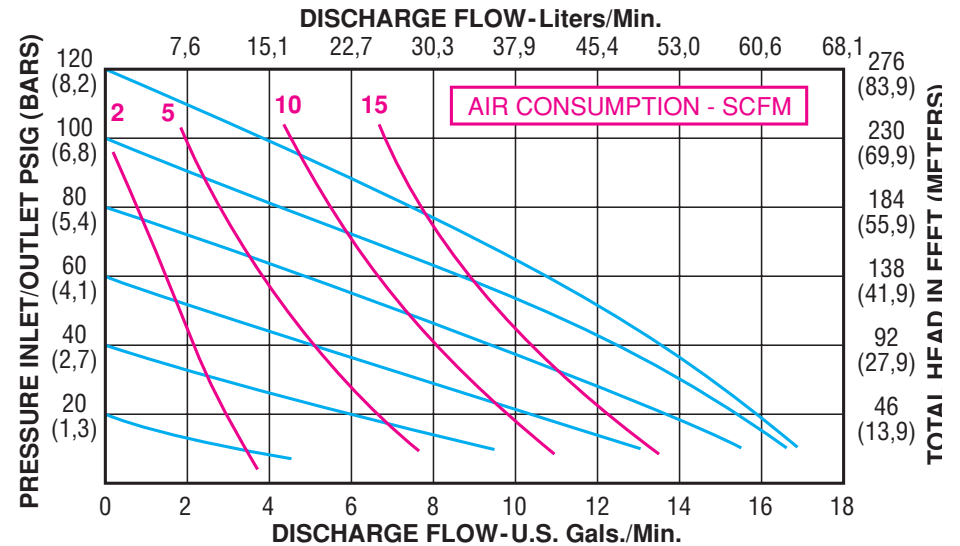

Typical Installation

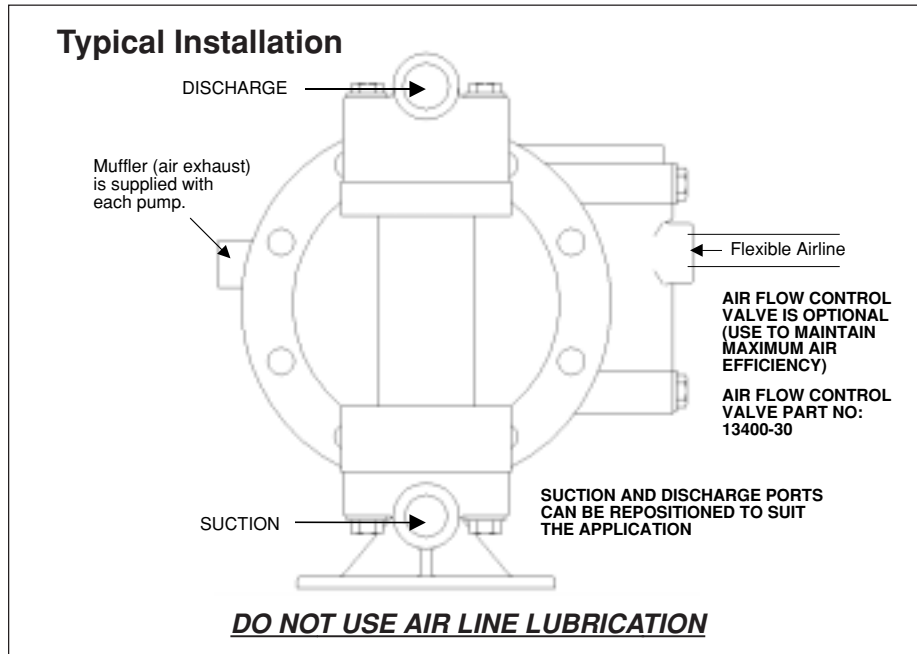

1/2" MODEL

Performance Plus Metallic
Serial Numbers
113000 and Above

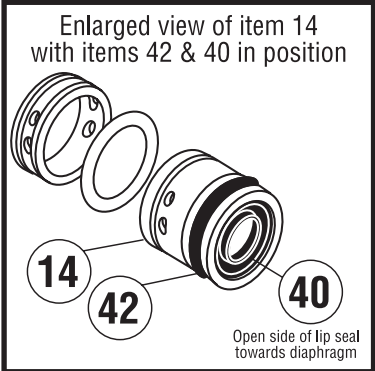
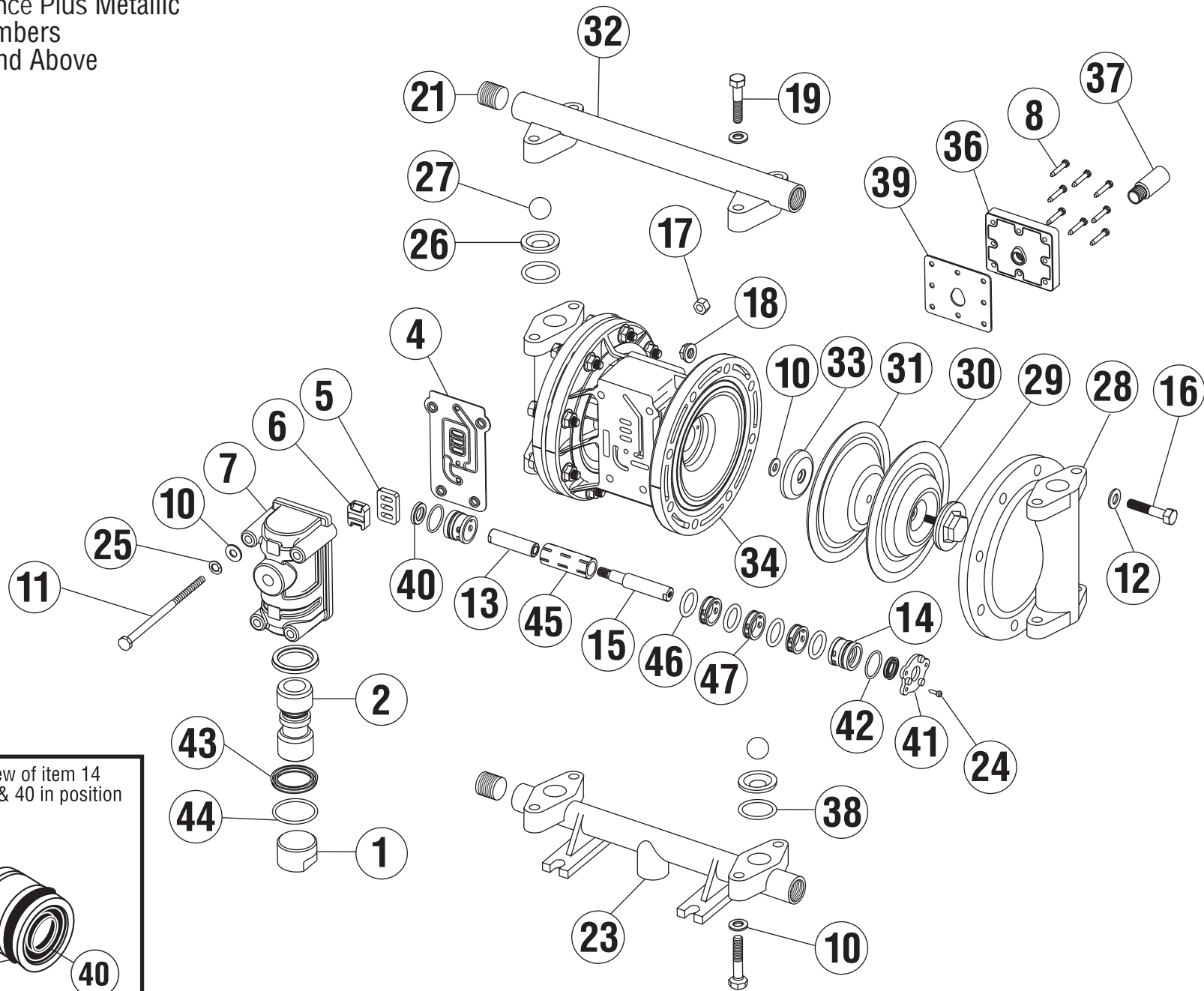

1/2" PERFORMANCE PLUS METALLIC MODELS

April 2015

ITEM	DESCRIPTION	QTY PER PUMP	MODELS	PART NO.	MATERIAL
1	AIR VALVE END PLUG	1	ALL MODELS	11703-60	POLYPRO
2	AIR VALVE SPOOL	1	ALL MODELS	10480-31	ACETAL
4	AIR VALVE GASKET	1	ALL MODELS	12116-19	NITRILE
5	SHUTTLE PLATE	1	ALL MODELS	10416-77	CERAMIC
6	SHUTTLE	1	ALL MODELS	10415-00	SPECIAL
7	AIR VALVE BODY	1	ALL MODELS	11614-60	POLYPRO
8	SLT WSHD SCREW (#8 X 1")	8	ALL MODELS	12525-26	SS
10	FLAT WASHER (1/4")	14	ALL MODELS	12300-26	SS
11	CAP SCREW (1/4" X 4-1/2")	4	ALL MODELS	12513-26	SS
12	FLAT WASHER (5/16")	16	ALL MODELS	12314-26	SS
13	DIAPHRAGM ROD (Short)	1	ALL MODELS	*	SS
14	END SPACER (Pilot Sleeve)	2	ALL MODELS	10204-40	POLYPRO
15	DIAPHRAGM ROD (Long)	1	ALL MODELS	*	SS
16	HEX BOLT (5/16" X 1-3/8")	16	ALL MODELS	12546-26	SS
17	HEX NUT (1/4" - 20)	4	ALL MODELS	12600-26	SS
18	FLANGE HEX NUT (5/16" - 18)	16	ALL MODELS	12608-26	SS
19	HEX HEAD (1/4"- 20 X 1-3/4")	8	ALL MODELS	12500-26	SS
21	MANIFOLD PLUG	3	A -PUMPS S -PUMPS	12208-20 12208-26	AL SS
23	SUCTION MANIFOLD	1	A -PUMPS S -PUMPS	10514-20 10514-26	AL SS
24	SELF TAP SCREW (#6 X 1/2")	6	ALL MODELS	12510-26	SS
25	LOCK WASHER	4	ALL MODELS	12350-26	SS
26	VALVE SEAT	4	S -PUMPS AB, AE, AV AT	10900-26 10900-40 10900-42	SS POLYPRO NYLON
27	BALL	4	AB, SB AT, SP AE, SE AV, SV	11000-19 11000-45 11000-23 11000-13	GEOLAST PTFE SANTO VITON
	STAINLESS STEEL	OPT	ALL MODELS	11000-26	SS
28	OUTER CHAMBER	2	A -PUMPS S -PUMPS	10720-20 10720-26	AL SS
29	OUTER DIAPHRAGM PLATE	2	A -PUMPS S -PUMPS	11208-20 11208-26	AL SS
30	OVERLAY	2	AT, SP	11400-59	PTFE
31	DIAPHRAGM	2	AB, SB AE, AT, SE, SP AV, SV	10600-19 10600-23 10600-13	GEOLAST SANTO VITON

ITEM	DESCRIPTION	QTY PER PUMP	MODELS	PART NO.	MATERIAL
32	DISCHARGE MANIFOLD	1	A -PUMPS S -PUMPS	10520-20 10520-26	AL SS
33	INNER DIAPHRAGM PLATE	2	ALL MODELS	11100-40	POLYPRO
34	INTERMEDIATE	1	ALL MODELS	11521-60	POLYPRO
36	MUFFLER PLATE	1	ALL MODELS	13111-60	POLYPRO
37	EXTERNAL MUFFLER	1	ALL MODELS	13008-00	SPECIAL
38	O-RING (Valve Seat)	4	AB, SB AT, SP AE, SE AV, SV	11904-11 11904-17 11904-15 11904-13	NITRILE PTFE EPDM VITON
39	GASKET (Muffler Plate)	1	ALL MODELS	12117-19	NITRILE
40	LIP SEAL (Diaphragm Rod)	2	ALL MODELS	12000-76	NITRILE
41	RETAINING PLATE	2	ALL MODELS	12708-40	POLYPRO
42	O-RING (End Spacer)	2	ALL MODELS	11923-11	NITRILE
43	LIP SEAL (Air Valve)	2	ALL MODELS	12003-76	NITRILE
44	O-RING (Air Valve End Plug)	1	ALL MODELS	11913-11	NITRILE
45	PILOT SLEEVE	1	ALL MODELS	10105-31	ACETAL
46	O-RING (Pilot Sleeve)	4	ALL MODELS	11920-16	URETHANE
47	INNER SPACER (Pilot Sleeve)	3	ALL MODELS	10203-40	POLYPRO

*** NOTE: DIAPHRAGM ROD AVAILABLE ONLY AS AN ASSEMBLY.**

DIAPHRAGM ROD ASSEMBLY Items 13 & 15	1	ALL MODELS	33000-00	SS
---	---	------------	----------	----

OPTIONAL ASSEMBLIES AVAILABLE

AIR VALVE ASSEMBLY Items 1, 2, 4, 5, 6, 7, 43, 44	1	ALL MODELS	42000-60	POLYPRO
--	---	------------	----------	---------

PILOT SLEEVE ASSEMBLY Items 14, 40, 42, 45, 46, 47	1	ALL MODELS	41000-00	VARIOUS
---	---	------------	----------	---------

REPAIR KITS - WET END				
Includes items 26, 27, 31, 38 & (30 - Used in pumps built w/ PTFE)				
To order a wet end repair kit, add "KIT" to the pump model. e.g. AB-05 KIT				

NOTES:

1. SS = STAINLESS STEEL AL = ALUMINUM