

# SAFETY MANUAL— READ FIRST!

**IMPORTANT:** READ THESE WARNINGS AND SAFETY PRECAUTIONS PRIOR TO INSTALLATION OR OPERATION. FAILURE TO COMPLY WITH THESE INSTRUCTIONS COULD RESULT IN PERSONAL INJURY AND OR PROPERTY DAMAGE. RETAIN THESE INSTRUCTIONS FOR FUTURE REFERENCE.

**⚠ WARNING** Pump, valves and all containers must be properly grounded prior to handling flammable fluids and/or whenever static electricity is a hazard.

**⚠ WARNING** Prior to servicing the pump, ensure that the air and fluid lines are closed and disconnected. While wearing personal protective equipment, flush, drain and process liquid from the pump in a safe manner.

**⚠ CAUTION** Do not connect a compressed air source to the exhaust port of the pump.

**⚠ CAUTION** Ensure that the muffler is properly installed prior to pump operation.

**⚠ CAUTION** Do not lubricate air supply.

**⚠ CAUTION** When selecting pump materials, be aware of the following temperature limitations:

Buna-N (Nitrile):	10°F to 180°F (-12C to 82C)
Geolast®:	10°F to 180°F (-12C to 82C)
EPDM:	-40°F to 280°F (-40C to 138C)
Santoprene®:	-40°F to 225°F (-40C to 107C)
Viton® (FKM):	-40°F to 350°F (-40C to 177C)
PTFE:	40°F to 220°F (4C to 104C)
Polyethylene:	32°F to 158°F (0C to 70C)
Polypropylene:	32°F to 180°F (0C to 82C)
PVDF:	0°F to 250°F (-18C to 181C)
Nylon:	0°F to 200°F (-18C to 93C)

Temperature limits are solely based upon mechanical stress and certain chemicals will reduce the maximum operating temperature. Consult a chemical resistance guide for chemical compatibility and a more precise safe temperature limit. Always use minimum air pressure when pumping at elevated temperatures.

**⚠ WARNING** = Hazards or unsafe practices which could result in severe personal injury, death or substantial property damage

**⚠ CAUTION** = Hazards or unsafe practices which could result in minor personal injury, product or property damage.

**⚠ CAUTION** Do not exceed 120 psig (8.3 bar) air-inlet pressure.

**⚠ CAUTION** Ensure all wetted components are chemically compatible with the process fluid and the cleaning fluid.

**⚠ CAUTION** Ensure pump is thoroughly cleaned and flushed prior to installation into a process line.

**⚠ CAUTION** Always wear Personal Protective Equipment (PPE) when operating pump.

**⚠ CAUTION** Close and disconnect all compressed air and bleed all air from the pump prior to service. Remove all process fluid in a safe manner prior to service.

**⚠ CAUTION** Blow out all compressed air lines in order to remove any debris, prior to pump installation.

**⚠ CAUTION** Ensure air exhaust is piped to atmosphere prior to a submerged installation.

**⚠ CAUTION** Ensure all hardware is set to correct torque values prior to operation.

**⚠ CAUTION** Ensure that the selected pump model number is made from the correct material and matches that which was ordered.

## INSTALLATION

**Notice:** Re-torque fasteners prior to use. Refer to torque requirements listed in maintenance manual and attached to pump.

1. A lube-free, clean, dry compressed air source (or any nonflammable, compressed gas) is recommended. Use a filter that is capable of filtering out particles larger than 50 microns.
2. All pumps should be mounted in an upright position with the exception of the 1/4" models which may be rotated 360° to suit the application.
3. When particles exceed the maximum particle specification of the pump or are sharp enough to cut elastomers install a particle fluid filter on the fluid suction line.
4. Fluid suction lines and air exhaust lines should never be smaller than specified pipe size of the pump.
5. Apply PTFE (Teflon®) tape to threads upon assembly to prevent leakage.
6. Never use pipe dope on air line connections.
7. Never use collapsible tube on fluid inlet.
8. Do not exceed 10 ft-lbs of torque on plastic pipe threads.
9. If changing to a different application reconfirm compatibility of fluid.

### SUBMERGED APPLICATIONS

1. Fluid must be compatible with fasteners and intermediate material.
2. Pipe exhaust above the level of the fluid.

### HIGH VISCOSITY APPLICATIONS

1. Position the pump close to or below the level of the fluid source
2. Suction lines should be increased in size - up to three times the size of the inlet manifold. Dual manifolds may be used when available.
3. Start the pump slowly using a valve on the air line.

### LOW TEMPERATURE AND UV EXPOSURE

1. Polypropylene tends to embrittle at freezing temperatures. Pump must be insulated or heated, otherwise use pumps with different materials of construction.
2. If excessive icing occurs at the pump exhaust, air source must be dried using mechanical means or through the introduction of ethyl alcohol in the air line.
3. UV rays will damage polypropylene pumps, either shroud the pumps from UV rays or use pumps with UV stabilized materials.

### GENERAL MAINTENANCE

1. Check periodically for product or air leakage. Tighten any joint where leakage is occurring.
2. When pumping hazardous or toxic materials, diaphragms should be replaced at regularly scheduled intervals based upon pump usage.
3. In freezing temperatures, the pump must be completely drained when idle.
4. When pumping highly abrasive fluids reduce discharge flow rate or reduce air pressure to prolong diaphragm life.
5. If you are pumping a material that will settle or compact, the pump must be flushed before shut down.

## TROUBLE SHOOTING

### AIR IS APPLIED TO PUMP BUT PUMP IS NOT STARTING

1. Clean filters and debris from all fluid lines.
2. Make sure all valves on fluid lines are open.
3. Inspect diaphragms for rupture.
4. Air pressure must not be below 20 psi (1,3 bar).

### PUMP IS PUMPING BUT NOT PRIMING

1. Check all suction line connections for leakage.
2. Inspect check valves for wear or debris.
3. Suction lift specifications may be exceeded.
4. If fluid is viscous use larger suction lines.

### LEAKAGE

1. Retorque all fasteners to specified torque requirements.
2. Replace o-rings.
3. Inspect diaphragms for rupture.

### LOW FLOW RATE

1. Confirm air pressure and air capacity at the air valve as required.
2. Check for leaks in suction line or obstructions in lines.
3. If fluid is viscous use larger lines.
4. Viscosity of fluids may have increased if temperature is lower.

### AIR IN DISCHARGE LINES

1. Check for leaks in suction lines.
2. Inspect diaphragms for rupture.

### ERRATIC CYCLING

1. Inspect check valve seats for debris.
2. Inspect fluid lines for debris.
3. Automatic valves must be properly functioning.
4. Viscosity of product may be changing.

### PREMATURE DESTRUCTION OF WETTED COMPONENTS

1. If fluid is abrasive, slow down pump or increase size of pump.
2. Filter fluid for sharp objects.
3. Make sure fluid is compatible with wetted materials.

# 1-1/2", 2" PERFORMANCE PLUS MAINTENANCE MANUAL

## CHECK VALVE AND O-RING MAINTENANCE

1. Flush and neutralize the pump to be certain all corrosives or hazardous materials are removed prior to any maintenance. This procedure should always be followed when returning pumps for factory service also.
2. **PLASTIC PUMPS:** Remove the elbow to outer pumping chamber band clamps (35). Suction check valve seats (26) and check balls (27) are located inside of the bottom of the outer chamber (28). Gently remove and inspect for excessive wear, pitting or other signs of degradation. Inspect valve seat o-rings (24) and replace if necessary. Discharge check valves are located inside of the bottom of the discharge elbows (32). Repeat procedure for inspection of discharge check valves.
- 2A. **METAL PUMPS:** To inspect the check valves, remove the cap screws (19) from manifold sections (21, 23). Repeat procedure above. There are no manifold o-rings in the metallic pumps.
3. To inspect the manifold o-rings remove the manifold band clamps from each manifold assembly. Inspect and replace o-rings if necessary. Then reassemble, lightly tighten fasteners. The check ball should fit into the curved portion of the valve seat facing upward when reinserted into the valve seat location. Tighten all external fasteners to final torque requirement after pump is completely assembled.

**NOTE: When using pumps built with PTFE o-rings always replace with new PTFE o-rings, since the original o-rings will not reseal the pump.**

## DIAPHRAGM AND PILOT SLEEVE ASSEMBLY MAINTENANCE

4. To inspect diaphragms remove cap screws (16) and reinforcement bracket (25) from the outer pumping chambers. If replacement is necessary due to abrasion or rupture unscrew the outer diaphragm plates (29). Models that are built with PTFE elastomers will have a PTFE overlay (30) that faces the outer pumping chamber (28) and a back-up diaphragm (31) on the air side of pump. Pumps without PTFE will contain only the back-up diaphragms.
5. If there has been a diaphragm rupture and corrosive or viscous fluid has entered the air side of pump the complete air system should be inspected. After removing diaphragms, inner diaphragm plate (33), and flat washer (47) the pilot sleeve assembly (13, 14, 15, 42, 45, 48) and diaphragm rod assembly (34, 49) may be removed by removing the retaining plates (46) (you may only need to remove one retaining plate) and pushing the entire unit out through the bore in the intermediate (41). Diaphragm rod assembly must be unscrewed to remove pilot sleeve.  
**NOTE: To aid in reassembly use a non-synthetic, petroleum based lubricating grease without EP additives. Carleton-Stuart MagnaLube G is recommended.**
6. Clean or replace any components that have excessive wear, dirt build-up, or chemical attack. Lube all components prior to reassembling. Reassemble pilot sleeve spacers, o-rings and lip seals (14) within bore of intermediate. Make sure that the open side of the lip seals is facing outward toward the diaphragms. Also make sure that the end pilot spacers (45) are at the end on either side of the pilot sleeve assembly and all inner spacers (48) are separated by o-rings. Next carefully insert the diaphragm rod assembly with pilot sleeve assembly inside the bore. Reattach retaining plates. Do not over tighten self-tapping screws (38).
7. With the curved side of the inner diaphragm plate facing the diaphragm, assemble onto outer diaphragm plate stud and then screw assembly into diaphragm rod. Push diaphragm rod to opposite side of intermediate and add the opposite diaphragm assembly. **Tighten the outer diaphragm plates to 372 in-lbs (42,04 NM) of torque.** Assemble the outer chamber, reinforcement brackets and bolts first on

the side where the diaphragm has been inverted. Next reach under the opposite diaphragm assembly and pull diaphragm rod to opposite side (a large flat screwdriver may be used as an aid in this process) and assemble remaining outer chamber, reinforcement brackets and cap screws. When positioning outer diaphragm chambers onto intermediate make sure that witness lines are matching.

**NOTE:** If air valve has been removed, proper orientation of air system with fluid chambers must be observed. The top of the intermediate has a single vertical air passage slot on the air valve mounting face while the outer chamber check ball cavity should be pointing downward.

**PLASTIC PUMPS NOTE:** When positioning band clamps use soapy water or a compatible lubricating spray on the inside of band clamps to aid assembly. Tap with a mallet on the outside of clamp to help position the clamp while tightening the fasteners. The band clamp fasteners and cap screws are stainless steel. To prevent galling always apply an anti-seize compound to the thread. Tighten all external fasteners to final torque requirement after pump is completely assembled.

8. Position the reassembled manifolds making sure of the proper orientation in relation to the air valve for your application. Also make sure that the valve seat o-rings do not shift from their grooves during reassembly. Flat washers should be placed under the head of each cap screw and nut. Tighten all external fasteners to final torque requirement after pump is completely assembled.
- 8A. **METAL PUMPS:** Position manifold/elbow sections making sure that the valve seat o-rings do not shift from their grooves. Tighten fasteners on bolts loosely.

## EXTERNAL FASTENER TORQUE REQUIREMENTS

**NOTE: When reassembling loosely tighten all external fasteners adjusting and aligning and gradually, in an alternating fashion, tighten to torque requirements listed below.**

CHAMBER BOLTS (Outer Chamber – all versions), 15 ft-lbs (20,34 NM)

BAND CLAMPS (Manifolds and Elbow), 80 in-lbs (9,04 NM)

METAL PUMPS (Elbow to Chamber Bolts), 37 ft-lbs (50,17 NM)

AIR VALVE CAP SCREWS, 40 in-lbs (4,52 NM)

## AIR VALVE MAINTENANCE

9. To evaluate air valve components, remove the six cap screws (11), washers, (8, 10) and nuts from the air valve body (7). The valve plate (5) and shuttle (6) may be inspected by removing them from their location in the slot in the back of the air valve. Inspect for scratches or surface irregularities. Replace if necessary. To remove the plug (1) at the bottom of the air valve, point the bottom of the air valve safely away from people, direct compressed air through one of the lower holes in the back of the air valve body and the plug will shoot out. Next push the air valve spool (2) out of the air valve body. Gently reach in and pull lip seals (43) out of inside bore of the air valve body. Check for cracks, splitting or scratches. Clean components if replacement is not necessary. Inspect plug o-ring (44) for any damage and replace if necessary and reinsert in o-ring groove.  
**NOTE: Make sure that the open side of the two lip seals face each other when reassembling air valve. Lube all components with suggested maintenance grease as an aid in reassembly.**
10. Reinsert air valve spool inside of air valve body. Place shuttle on middle rib of air valve spool through the square slot in back of air valve. If using original valve plate lubricate side of plate that was facing the shuttle (or if new valve plate is used lubricate the lapped and polished side of plate) and place the lubricated side next to the shuttle in the slot. Press valve plug into air valve body, chamfered end first.
11. Check that gasket (4) is not cracked and If damaged, replace.
12. After gasket is pressed back into position, align air valve onto intermediate and reinsert the six cap screws with lock washer and flat washers. **Apply 40 in-lbs (4,52 NM) of torque to fasteners.**

U.S. Patent Number 5232352

## SPECIFICATIONS: 1-1/2", 2" PERFORMANCE PLUS

### 1-1/2" CAPACITY:

Adjustable 0-130 GPM (492 LPM)

### 2" CAPACITY:

Adjustable 0-180 GPM (681 LPM)

### MAXIMUM TEMP:

PVDF models – 200°F (93°C)

Other plastic models – 150°F (66°C)

Metallic models – 200°F (93°C)

### MAXIMUM AIR PRESSURE:

120 psi (8,2 bar)

### MINIMUM AIR PRESSURE:

20 psi (1,3 bar)

### WEIGHT 1-1/2" Models:

Poly models – 46lbs (20,8 kg)

PVDF models – 65lbs (29,4 kg)

Alum models – 60lbs (27,2 kg)

SS models – 133lbs (60,3 kg)

### WEIGHT 2" Models:

Poly models – 48lbs (21,7 kg)

PVDF models – 69lbs (31,3 kg)

Alum models – 61lbs (27,7 kg)

SS models – 133lbs (60,3 kg)

### DRY LIFT:

Models with PTFE balls – 10 feet (3 meters)

Other models – 15 feet (4,5 meters)

### MAXIMUM SOLIDS:

1/4" (6,4 mm)

### AIR SUPPLY:

Inlet – 3/4" NPT Female (BSP compatible)

Outlet – 3/4" NPT Female

### FLUID INLET/DISCHARGE:

1-1/2" Flange (ANSI and DIN compatible)

2" BSP Female (2" metal models)

2" Flange (2" plastic models)

(ANSI and DIN compatible)

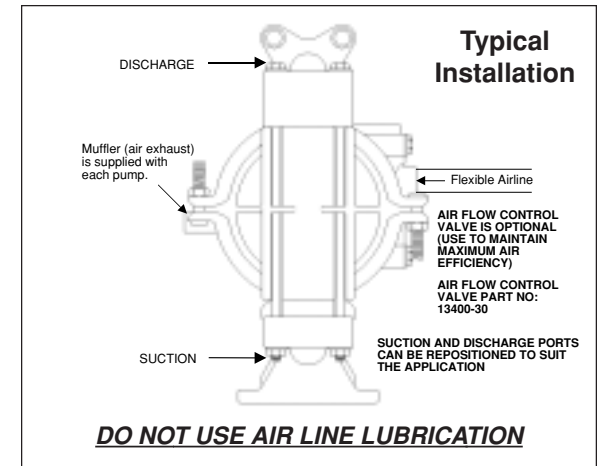

## 1-1/2" DIMENSIONS Dimensions in inches and (mm)

### Plastic

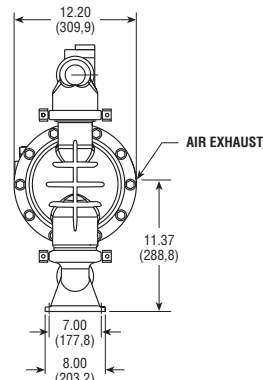
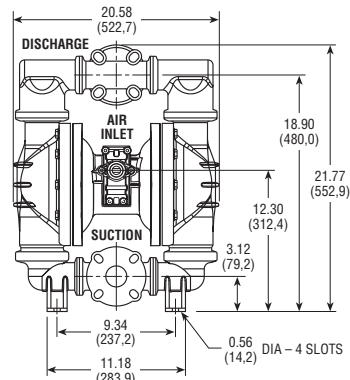

### Metallic

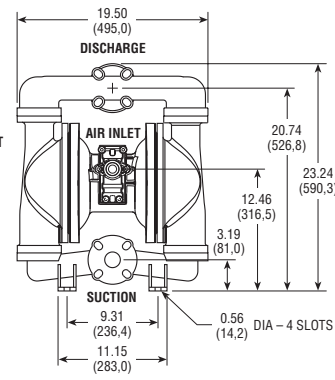

## 2" DIMENSIONS Dimensions in inches and (mm)

### Plastic

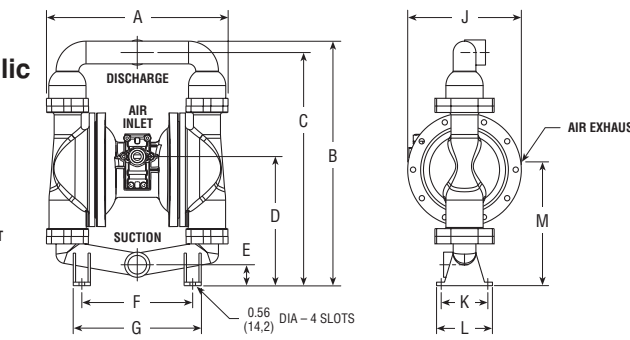
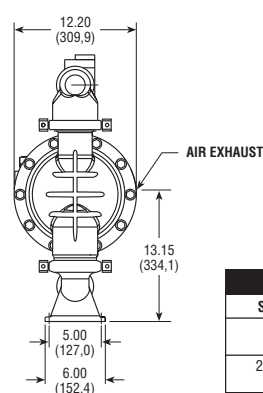
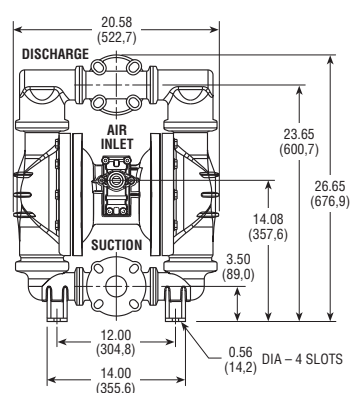

MODEL	DIMENSIONS Inches / (mm)										
Size (Inlet/Outlet)	A	B	C	D	E	F	G	J	K	L	M
2" Aluminum NPT & BSP	19.50 (495.0)	26.26 (667.0)	25.04 (636.0)	13.86 (352.0)	2.25 (57.1)	10.06 (255.5)	12.00 (304.8)	12.20 (309.9)	5.00 (127.0)	6.00 (152.4)	12.90 (327.6)
2" Stainless Steel NPT & BSP	19.50 (495.0)	24.62 (625.3)	23.00 (584.2)	15.05 (382.3)	3.50 (89.0)	12.00 (304.8)	13.85 (351.5)	12.20 (309.9)	5.00 (127.0)	6.00 (152.4)	14.10 (358.1)
Flanged 2" Flange	19.50 (495.0)	24.62 (625.3)	21.62 (549.2)	13.25 (336.6)	3.50 (89.0)	12.00 (304.8)	13.85 (351.5)	11.88 (301.8)	5.00 (127.0)	6.00 (152.4)	12.75 (324.0)

## 1-1/2" PERFORMANCE CURVE

(Based on water-flooded suction)

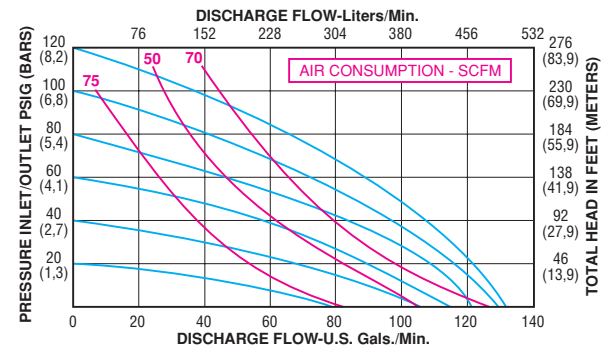

## 2" PERFORMANCE CURVE

(Based on water-flooded suction)

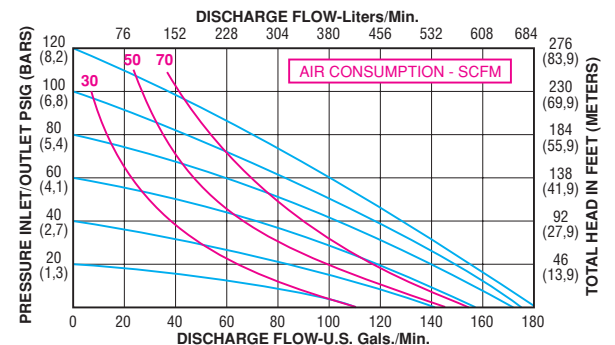

# 2" MODEL

Performance Plus Metallic  
Serial Numbers  
143700 and Above

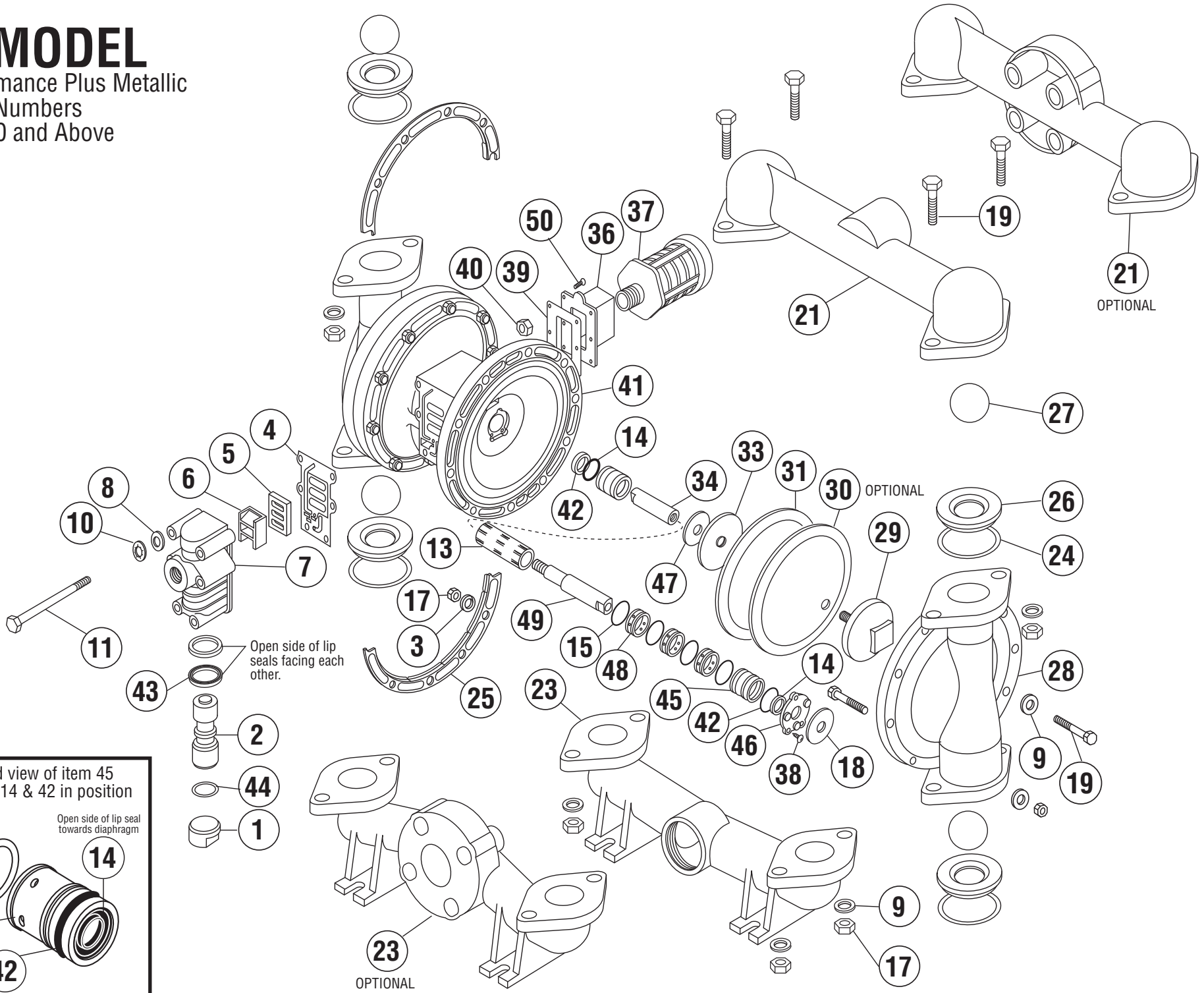

Open side of lip seals facing each other.

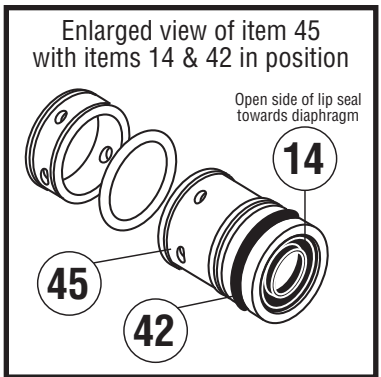

**2" PERFORMANCE PLUS METALLIC MODELS**

**APRIL 2015**

ITEM	DESCRIPTION	QTY PER PUMP	PUMP MODELS	PART NUMBER	MATERIAL
1	AIR VALVE END PLUG	1	ALL MODELS	11703-60	POLYPRO
2	AIR VALVE SPOOL	1	ALL MODELS	10481-31	ACETAL
3	COMPRESSION WASHER	20	ALL MODELS	12319-26	SS
4	AIR VALVE GASKET	1	ALL MODELS	12121-19	NITRILE
5	SHUTTLE PLATE	1	ALL MODELS	10450-77	CERAMIC
6	SHUTTLE	1	ALL MODELS	10430-00	SPECIAL
7	AIR VALVE BODY	1	ALL MODELS	11617-60	POLYPRO
8	FLAT WASHER	6	ALL MODELS	12300-26	SS
9	FLAT WASHER	28	ALL MODELS	12306-26	SS
10	LOCK WASHER (1/4")	6	ALL MODELS	12350-26	SS
11	CAP SCREW (1/4" X 6")	6	ALL MODELS	12515-26	SS
13	PILOT SLEEVE	1	ALL MODELS	10106-31	ACETAL
14	LIP SEAL (Diaphragm Rod)	2	ALL MODELS	12002-76	NITRILE
15	O-RING (Pilot Sleeve)	4	ALL MODELS	11919-16	URETHANE
17	HEX NUT (1/2" - 13)	28	ALL MODELS	12604-26	SS
18	BUMPER	2	ALL MODELS	12317-16	URETHANE
19	CAP SCREW (1/2" X 2-1/2")	28	ALL MODELS	12522-26	SS
21	DISCHARGE MANIFOLD, THREADED NPT	1	AB,AE,AN,AV,AT	10539-20	AL
	DISCHARGE MANIFOLD, THREADED BSP		-P15 MODELS	10540-20	AL
	DISCHARGE MANIFOLD, FLANGED		-P30 MODELS	10524-20	AL
	DISCHARGE MANIFOLD, THREADED NPT		SB, SE, SP, SV	10586-26	316 SS
	DISCHARGE MANIFOLD, THREADED BSP		-P15 MODELS	10587-26	316 SS
	DISCHARGE MANIFOLD, FLANGED		-P30 MODELS	10524-26	316 SS
DISCHARGE MANIFOLD, TRI-CLAMPED	OPT	-X44 MODELS	10577-26	316 SS	
23	SUCTION MANIFOLD, THREADED NPT	1	AB,AE,AV,AN,AT	10536-20	AL
	SUCTION MANIFOLD, THREADED BSP		-P15 MODELS	10537-20	AL
	SUCTION MANIFOLD, FLANGED		-P30 MODELS	10518-20	AL
	SUCTION MANIFOLD, THREADED NPT		SB, SE, SP, SV	10588-26	316 SS
	SUCTION MANIFOLD, THREADED BSP		-P15 MODELS	10589-26	316 SS
	SUCTION MANIFOLD, FLANGED		-P30 MODELS	10518-26	316 SS
SUCTION MANIFOLD, TRI-CLAMPED	OPT	-X44 MODELS	10578-26	316 SS	
24	O-RING (Valve Seat)	4	AB, AN, SB	11926-11	NITRILE
			AT, SP	11926-17	PTFE
			AV, SV	11926-13	VITON
			AE, SE	11926-15	EPDM
25	POWER RING (Set)	2	ALL MODELS	12812-26SET	SS
26	VALVE SEAT	4	AB, AN, AE	10918-40	POLYPRO
			AT,AV	10918-42	NYLON
			SB,SE,SP,SV	10918-26	316 SS
27	BALL	4	AB, SB	11004-19	GEOLAST
			AT, SP	11004-45	PTFE
			AN	11004-21	NITRILE
			AE, SE	11004-23	SANTO
			AV, SV	11004-13	VITON
	BALL, HEAVY WEIGHT	OPT	HIGH VISCOSITY	11004-22	NITRILE
	OPT	ALL MODELS	11004-26	SS	

ITEM	DESCRIPTION	QTY PER PUMP	PUMP MODELS	PART NUMBER	MATERIAL
28	OUTER CHAMBER	2	AB,AE,AN,AV,AT	10724-20	AL
			SB, SE, SV, SP	10724-26	316 SS
29	OUTER DIAPHRAGM PLATE	2	AB,AE,AN,AV,AT	11211-20	AL
			SB, SE, SV, SP	11211-26	316 SS
30	OVERLAY	2	AT, SP	11403-59	PTFE
31	DIAPHRAGM	2	AB, AN, SB	10603-19	GEOLAST
			AV, SV	10603-13	VITON
			ALL OTHERS	10603-23	SANTO
		OPT	-X45 MODELS	10603-86	COND. SANTO
33	INNER DIAPHRAGM PLATE	2	ALL MODELS	11103-25	PS
34	DIAPHRAGM ROD (Short)	1	ALL MODELS	*	SS
36	MUFFLER PLATE	1	ALL MODELS	13107-60	POLYPRO
37	EXTERNAL MUFFLER	1	ALL MODELS	13001-00	SPECIAL
38	SCREW (#6 X 3/4")	6	ALL MODELS	12549-26	SS
39	GASKET (Muffler Plate)	1	ALL MODELS	12108-11	NITRILE
40	HEX NUT (1/4" - 20)	6	ALL MODELS	12600-26	SS
41	INTERMEDIATE ZINC COATED FOR ATEX	1	ALL MODELS	11524-60	POLYPRO
			-X45 MODELS	11524-84	POLYPRO
42	O-RING (End Spacer)	2	ALL MODELS	11919-11	NITRILE
43	LIP SEAL (Air Valve)	2	ALL MODELS	12003-76	NITRILE
44	O-RING (Valve Plug)	1	ALL MODELS	11913-11	NITRILE
45	END SPACER (Pilot Sleeve)	2	ALL MODELS	10206-40	POLYPRO
46	RETAINING PLATE	2	ALL MODELS	12709-54	NYLON
47	FLAT WASHER	2	ALL MODELS	12315-25	PS
48	INNER SPACER (Pilot Sleeve)	3	ALL MODELS	10205-40	POLYPRO
49	DIAPHRAGM ROD (Long)	1	ALL MODELS	*	SS
50	SCREW (#8 X 3/4")	6	ALL MODELS	12540-26	SS
51	SCREW LUG - GROUNDING	1 (OPT)	-X45 MODELS	13416-25	PS

**\* DIAPHRAGM ROD AVAILABLE ONLY AS AN ASSEMBLY**

<b>DIAPHRAGM ROD ASSEMBLY</b>	1	ALL MODELS	35000-00	SS
Includes items 34 and 49				

**OPTIONAL ASSEMBLIES**

<b>AIR VALVE ASSEMBLY</b>	1	ALL MODELS	47000-60	VARIOUS
Includes items 1 thru 7, 43, 44				

<b>PILOT SLEEVE ASSEMBLY</b>	1	ALL MODELS	46000-00	VARIOUS
Includes items 13, 14, 15, 42, 45, 48				

<b>REPAIR KITS - WET END</b>				
Includes items 24, 26, 27, 31 & (30 - Used in pumps built w/ PTFE)				
To order a wet end repair kit, add "KIT" to the pump model. e.g. AL-20 KIT				

**NOTE:**

1. PS = PLATE STEEL, SS = STAINLESS STEEL, AL = ALUMINUM