

Operation and Installation Instructions

AH 20/32 S

Metal High-Pressure Diaphragm Pumps



AH 20 S



AH 32 S

ought to be studied before installing the pump

Original Instruction



Contents	Page
Introduction	2
General description of the machine	2
Storage	3
Code system	3
Operation in explosion-proof areas	4
Special operating conditions	4
Performance chart	6
Technical data	7
Recommended installation	7
Installation and operation	7
Torque values	8
Further safety hints	9
Additional temperature hints	10
Disassembly	11
Hints and tips for reassembly	12
Optional equipment	13
Trouble shooting	14
Exploded view	16
Spare part list	17
Dimensions	18

Introduction

ALMATEC high-pressure diaphragm pumps are constructed according to the state of the art and they are reliable. Imminent danger by operating error or misuse can lead to damages of properties and/or persons. The pumps are to be applied for the intended use and in a safety-related proper condition only. Each person working on the ALMATEC high-pressure diaphragm pumps concerning installation, start-up, handling or maintenance has to read this manual completely and in an attentive way and has to follow all mentioned procedures and safety notes.

General description of the machine, appropriate use and residual dangers

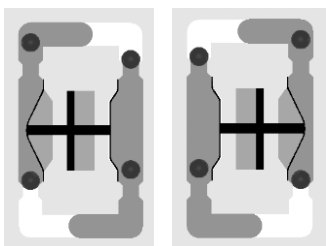

The ALMATEC AHS Series pumps are oscillating positive displacement pumps and are based on the functional principle of double diaphragm pumps. The basic configuration consists of two external side housings with a center block between them. Each of the side housings contains a product chamber which is separated from the center block by a diaphragm. The two diaphragms are interconnected by a piston rod. Controlled by an air control system, they are alternately subjected to compressed air so that they move back and forth. The pressure booster centered between the diaphragms boosts the drive air pressure to more than twice its original value in the two product chambers. In the first diagram, the compressed air has forced the left-hand diaphragm towards the product chamber and displaced the liquid from that chamber through the open valve at the top to the discharge port. Liquid is simultaneously drawn in by the right-hand diaphragm, thus refilling the second product chamber. When the end of the stroke is reached, it reverses automatically and the cycle is repeated in the opposite direction. In the second diagram, liquid is drawn in by the left-hand diaphragm and displaced by the right-hand diaphragm.

The appropriate use of an Almatec high-pressure diaphragm pump of the AHS series refers to the liquid (or sludge) transport taking into account the operation parameter mentioned in this manual and in compliance of the given terms for commissioning, operation, assembly, disassembly and maintenance.

Even if all necessary safety measures described in this manual have been met, a residual danger exists by leakages or mechanical damages. At sealing areas or connections liquid can be released uncontrollably then.

Storage

In general the ALMATEC pump is delivered operational and packaged. If the unit is not installed right away, proper storage conditions are important for a trouble free operation later. The pump has to be protected from wetness, coldness, dirtying, UV-radiation and mechanical influences. The following storage conditions are recommended:

- Steady ventilated, dust and vibration free storage room
- Ambient temperature between 15°C and 25°C with a relative humidity below 65%
- Prevention of direct thermal influences (sun, heating)

Code system

PSG Germany GmbH is certified as a modern, quality-orientated enterprise according to DIN EN ISO 9001 and 14001. Before release for dispatch, any pump of the AHS series has to undergo an extended final control. The performance data registered during this are archived in our records and can be read back at any time.

As a general rule in the countries of the EU only such machines are allowed to take into operation, which are determined to meet the regulations of the EU machinery directive, the harmonized standards, European standards and the respective national standards. Hence the operator has to verify whether the ALMATEC pump manufactured and delivered properly according to the customers order meets the mentioned requirements.

Therefore make sure, before putting the pump into operation, that the pump and the used materials of construction are suitable for the provided application and the installation site. To check this, the exact pump code is required. This code, the serial number and the year of construction are noted on the identification plates on the pump itself. The wetted housing parts are made of stainless steel casting 1.4408 (SS 316). The material of the non-wetted housing parts center block and dual stage housing is PE conductive (AH 20 S) or Aluminium (AH 32 S).

The ALMATEC high pressure pumps AH 20/32 S are based on the ALMATEC pneumatic diaphragm pump range. Due to the integrated pressure transmission, it can achieve a discharge pressure of 15 bar with an air pressure of 7 bar.

Example to clarify the ALMATEC pump code:

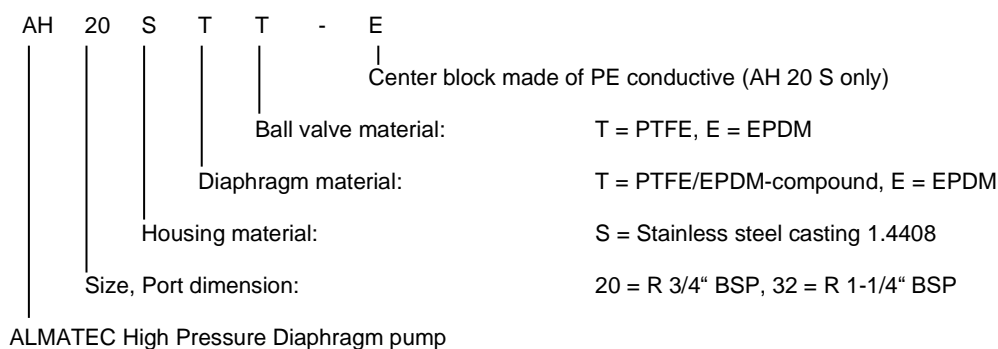

Operation in explosion-proof areas and for inflammable liquids

X = CAUTION! = Special operating conditions apply!

For pumping flammable liquids or in hazardous areas, pumps of the ADX series must be equipped with a control block in PE conductive (special equipment code E) instead of the standard control block in PA. In addition, the pump must be grounded via one of the marked threaded holes in the housing cheeks [1]. The ground connection must have a minimum cross-section of 6 mm². All other housing parts are conductively connected to each other.

The grounded ALMATEC air-operated diaphragm pumps with conductive control block of the AH S series are suitable for use in potentially explosive atmospheres of category 2 and 3 ("Zone 1" and "Zone 2" respectively), atmosphere G/D, which are subject to the scope of EU Directive 2014/34/EU. Conductive diaphragms (material code 68, 70, 72) can be used without restriction for pumping liquids in all explosion groups.

If non-conductive diaphragm materials are used (material code 67, 98), explosion group IIB applies within the pump for pump size AH 20 S up to including AH 32 S (regardless of the installation site).

Pipelines and product connections must be grounded separately. To avoid ignition hazards, the formation of dust deposits on the units must be prevented. Repairs in Ex areas may only be carried out after careful examination of the feasibility and only with appropriate tools. For marking Ex according to 2014/34/EU see the enclosed declaration of conformity and the corresponding sticker on the pump.

The interfaces for electrical accessories have been considered and do not represent a new potential ignition source.

The ignition protection type "c=constructive safety" was applied according to guideline EN ISO 80079-37.

Special operating conditions	AH 20 S	AH 32 S
Permissible ambient temperature °C (°F)	-10 – 50 (14-122)	
Permissible temperature compressed air °C (°F)	0 – 50 (32-122)	
Maximum drive and operating pressure bar (psi)	7 (101,5)	
Maximum operating temperature °C (°F) (X)	80 (176)	

The ATEX marking for gases and dusts is defined as follows according to 2014/34/EU:

In order to enable the optimum and flexible design of an ATEX pump to the customer-specific application, a differentiation is made in the marking between the installation location of the pump (hazardous area outside the pump) and the inside of the pump (hazardous area inside the pump).

Equipment category G (gases, mists, vapors)

Installation site: Category G

Inside the pump: Category G

Conductive ALMATEC air-operated diaphragm pumps may generally be used in explosion group IIC at the installation site (potentially explosive area outside the pump), since the solid housings are made of dissipative materials and the entire pump is grounded.

ATTENTION! Inside the pump, the permitted explosion group varies depending on the diaphragm material used:

When using **non-conductive diaphragms**, explosion group IIB applies inside the pump:

⊕ II 2/2 G Ex h IIB/IIC T6...T4 Gb/Gb X (inside the pump/installation site)

When using **conductive diaphragms**, explosion group IIC applies inside the pump:

⊕ II 2/2 G Ex h IIC/IIC T6...T4 Gb/Gb X (inside the pump/installation site)

Equipment category D (dusts)

Installation site: Category D

Inside the pump: Category G

Conductive ALMATEC air-operated diaphragm pumps may generally be used in dust group IIIC at the installation site (potentially explosive area outside the pump; equipment category D).

ATTENTION! Inside the pump (equipment category G), the approved explosion group varies depending on the diaphragm material used:

When using **non-conductive diaphragms**, explosion group IIB applies inside the pump:

⊕ II 2/2 D Ex h IIB/IIIC T 70°C...130°C Gb/Db X (inside the pump/installation site)

When using **conductive diaphragms**, explosion group IIC applies inside the pump:

⊕ II 2/2 D Ex h IIC/IIIC T 70°C...130°C Gb/Db X (inside the pump/installation site)

Performance charts

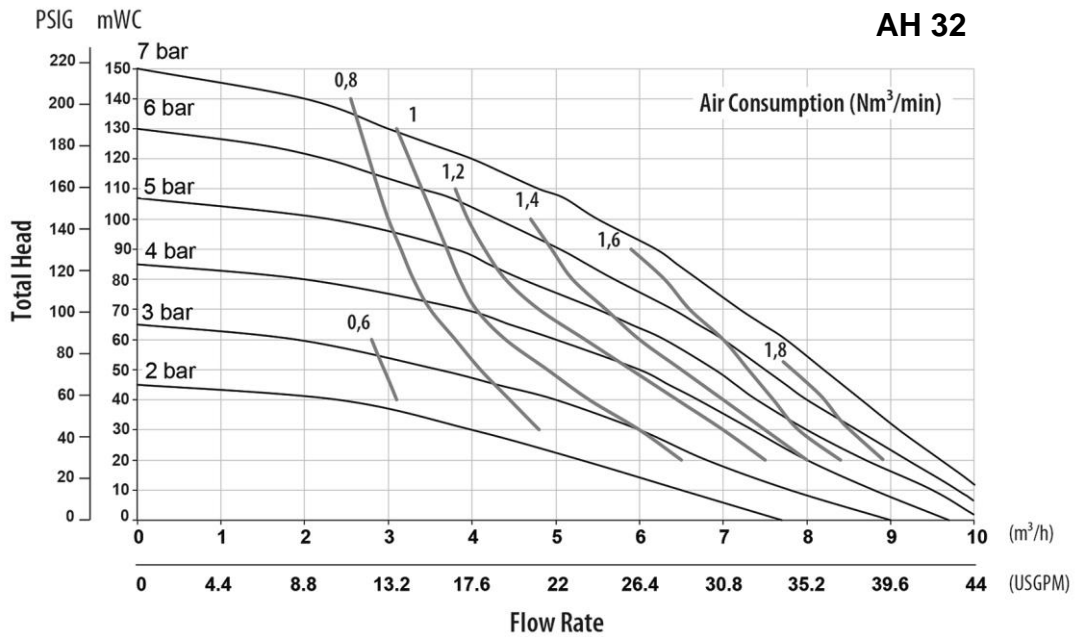
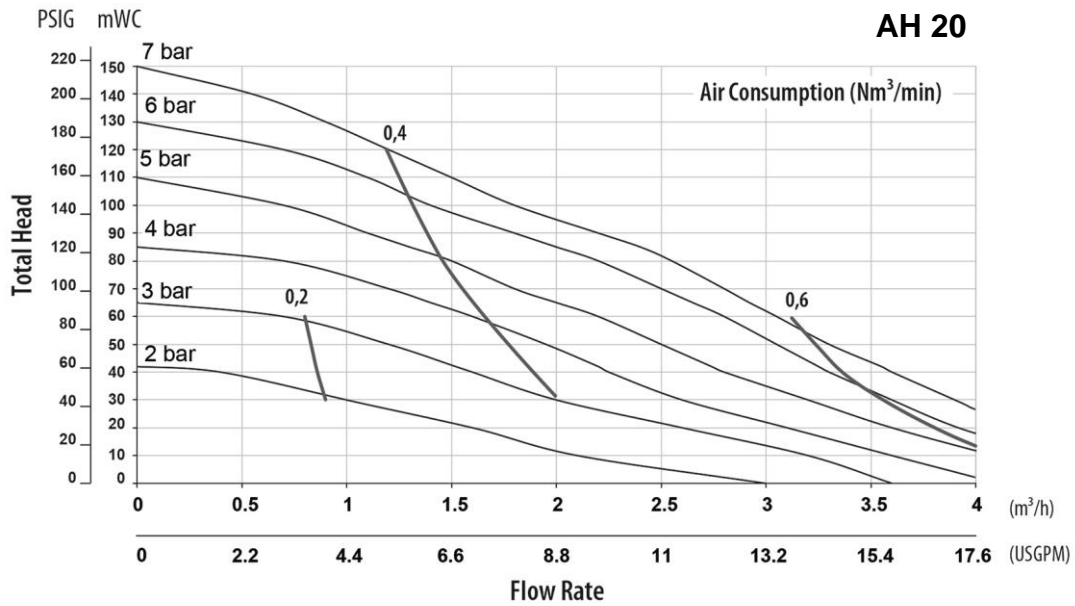

Performance data are in accordance with DIN EN ISO 9906. The data refer to water (20°C), without using of a pulsation damper.

Technical data	AH 20 S	AH 32 S
Dimensions mm (in.):		
width	220 (8.7)	324 (12.8)
depth	162 (6.4)	229 (9.0)
height	243 (9.6)	327 (12.9)
Nominal port size (BSP/NPT)	3/4"	1-1/4"
Air connection (BSP/NPT)	1/4"	1/2"
Weight kg (lbs)	8.5 (19)	28 (62)
Max. particle size of solids mm (in.)	9 (0.35)	12 (0.47)
Suction lift, dry mWC (ft)	2 (6.6)	2 (6.6)
Suction lift, wet mWC (ft)	9 (29.5)	9 (29.5)
Max. driving and operating pressure bar (psig)	7 (100)	7 (100)
Max. operating temperature °C (°F)	80 (176)	80 (176)
Sound pressure level acc. to DIN 45635, part 24, depending on the operating data [dB (A)]:		
driving pressure 3 bar	68-77	69-77
driving pressure 5 bar	73-84	71-84
driving pressure 7 bar	74-85	73-85

Recommended installation

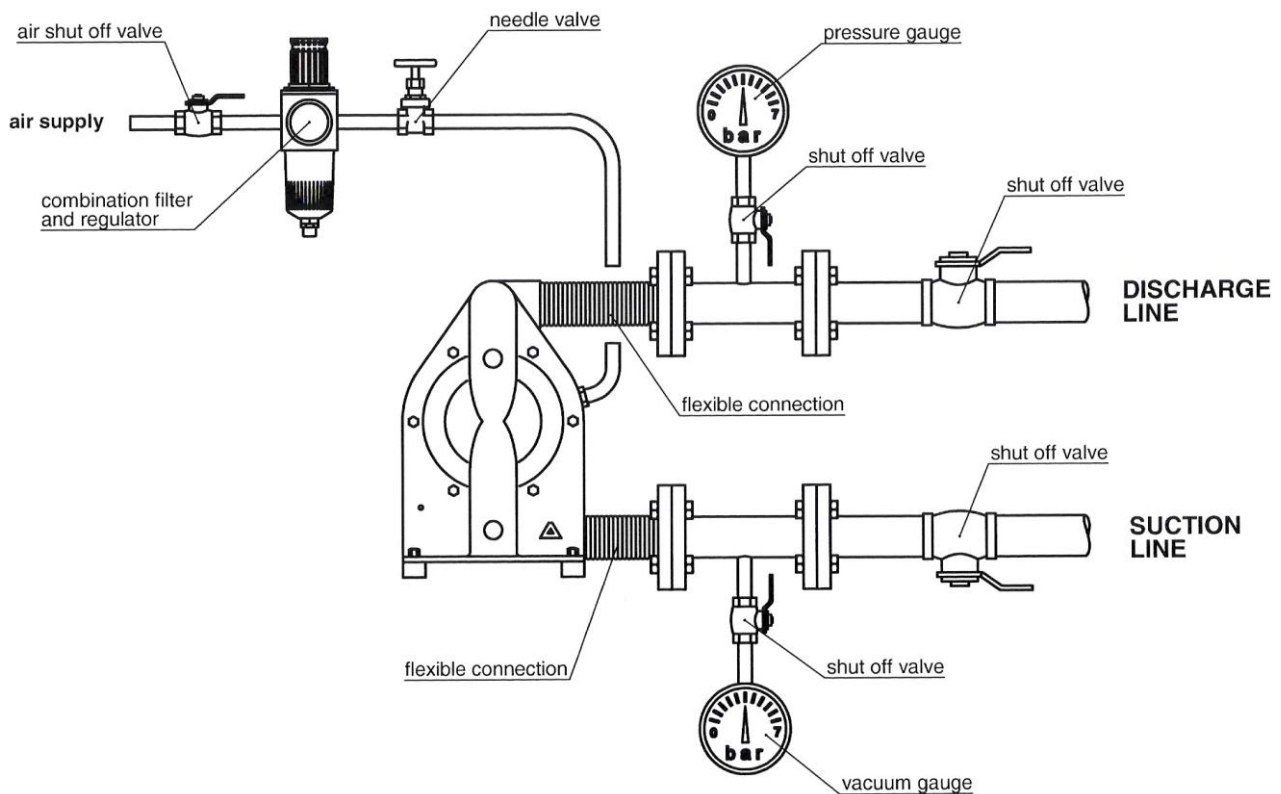

Installation and operation

The number in brackets, which is added to every part mentioned in the following explanations, refers to its position in the spare part list and the exploded view.

In general, the pump has to be connected load free. Neglecting this causes leakage and maybe even damages. To avoid vibrations, compensators are recommended. Before connecting the pump, take the yellow blind plugs out of the suction and discharge connections (2) as well as the air inlet (14) in the center block (12).

The operator is responsible for an adequately stability and an appropriate fixation of the piping according to the state of the art. To facilitate the installation and maintenance shut off valves should be installed right before and after the pump. The nominal width of the connection pipes has to be chosen in accordance to the connections of the pump. A smaller piping can cause cavitation (suction line) as well as a loss of performance (suction and discharge line). In case the pipe is too big, the dry suction capacity of the pump can decrease. Connect the suction line to the lower manifold (2) which can be swivelled carefully along its longitudinal axis into the position required. Seal the suction line diligently; hosepipes should be suitably armoured. A suction line continuously rising will prevent the formation of air locks in the line which would affect the suction lift. The discharge line has to be connected to the upper manifold (2) which can be swivelled along its longitudinal axis as well.

The air inlet (14) is located in the middle of the center block (12). Before installation make sure that the air supply pipe is free of solids. To supply the pump with driving air sufficiently, the pipe diameter should match the size of the air inlet. Take care that no dirt or particles can intrude into the pump during the connection, as these can accumulate inside the pump and can cause malfunctions. An air filter (15) directly behind the air inlet (14) prevents the entry of bulk particles.

The integrated air control system *PERSWING P*[®] is a precision-control that requires oil-free, dry and clean compressed air for optimal function. If humidity is expected, a water separator or air dryer has to be fitted to protect the pump from blocking by ice. The ideal condition is the dewpoint of air at -20°C. In humid surroundings, icing from the outside may occur despite the driving air is dried. If so, a prolonged waste-air-exhaust (ca. 500 mm by pipe or hose) can be helpful. When installing the pump into boards or cabinets, it has to be ensured that cold air does not get caught behind the muffler. In applications with a tendency to freezing at the waste air exhaust, good experiences in practise have been achieved by pre-heating the driving air to increase the distance to the dew point of the air. Doing so, it has to be considered that the driving air temperature generally may not exceed 50°C to avoid expansion and sticking effects on the air side. This max. air temperature is a well valid when using a compressor producing warm air which is e.g. often true for truck compressors.

The pressure of the driving air has to be limited to the amount required to meet the performance needed. Excessive pressure increases both the air consumption and the wear of the pump. The pump is regulated by tuning the flow rate of the air. An empty pump has to be driven slowly (e.g. via a needle-valve). The pump starts automatically and is self-priming when dry, thus it is not necessary to fill the suction line of the pump. The suction lift capacity of a liquid-filled pump, however, is much higher.

The pump is appropriate for running dry during slow operation. Dry running at high stroke frequency causes premature wear. The pumps can briefly (up to max. one hour) be operated against a closed discharge line. Throttling on the suction side may damage the pump. When the pump operation has been stopped by a closed discharge, the pressure equilibrium of the diaphragms must be ensured. This can be achieved by keeping the pump connected to the air supply pressure; for longer stoppage, the pump must be released from the pressure within the system on both fluid side and air supply side.

Torque values



Immediately before putting the pump into operation as well as after some hours of pumping, the housing bolts [7] have to be fixed according to the torque data of the following schedule, as the elements of construction "settle". Fixing all these parts is necessary as well after periods of stoppage, at temperature variations, after transport and dismantling the pump. In case of temperature varying between extremes or high temperature difference between the liquid and the surrounding, the housing bolts should be controlled more frequently (interval proposals are available on request).

Size	AH 20 S	AH 32 S
Torque values for housing bolts Nm (ft lbs):	12 (8.8)	30 (22)

Further safety hints



- Installation, operation, and maintenance by qualified staff only.
- Before start-up of the pump anyone should acquaint oneself with the explanations of the chapter troubleshooting (see pages 12/13). Only by this the defect quickly can be realized and eliminated in case of trouble. Problems which cannot be solved or with an unknown reason should be passed on to the manufacturer.
- Before any maintenance and service procedures arising on the pump or on the optional equipments, the complete installation has to be turned off and protected against accidental turn on. This is possible by a lockable emergency stop for the air supply of the pump. Additional a danger sign against restart should be attached.
- Pressure tests of the plant a pump is included in may only be carried out with the pump disconnected from the pressure on both ports or by using the pressure the pump develops while operating. The load of a pressure in the plant may damage the pump.
- Pump must not be operated with a positive suction pressure.
- Depending on the conditions of operation, the liquid conveyed might escape from the pump through the muffler in case of a diaphragm rupture (in this case muffler has to be replaced). For further safety requirements the optional equipment diaphragm monitoring and barrier chamber system are recommended.
- In case of a diaphragm rupture, it might be possible for the fluid pumped to intrude into the air side of the pump. In very adverse conditions - e.g. pressure within the fluid system during stopped air supply - the fluid might as well find its way into the air supply lines. To protect other devices like pulsation dampers or even pneumatic valves, it is recommended to protect the air supply line accordingly, e.g. via a non-return valve. This would as well avoid polluting the air supply line.
- The state of the muffler has to be inspected regularly, as a blocked muffler can be forced out of the pump. If this happens, damages of properties and/or persons cannot be excluded.
- Pumps of the AHS-Series must not be submerged.
- When blowing out the filter press, the pump has to be protected against the pressure by a valve or a slide.
- If the product tends to settle, the pump has to be flushed regularly. For larger solids a filter has to be installed in the suction line.
- In case of delivery of hot liquids the wetted pump must not standstill for a longer time, because it could lead to temporary leaks in the valve area and to a blockade of the air control system.
- The relevant effective security advises have to be respected.
- Pools of liquid which appear in the near outer area of the pump have to be inspected on danger potential, if necessary safety measures are to be taken.
- Chemical and biological reactions in the product chamber of the pump (mixture of different substances) and the freezing of the liquid have to be avoided.
- Before starting to disassemble the pump, take care that the pump has been emptied and rinsed. Both ports piping are to be closed and drained if applicable. Further the pump has to be cut off from any energy on the air and product side. If the pump is being deported from the plant, a reference about the delivered liquid has to be attached.
- Please respect the relevant additional security advices, if the pump has been used for aggressive, dangerous or toxic liquids (e.g. suitable protective equipment according to the safety data sheet of the liquid). In case of a diaphragm rupture, it is possible that residues of the liquid remain behind the diaphragms, in the area of the air control system and at the muffler, despite of several flushing processes. Hence, appropriate safety equipment according to the safety data sheet of the liquid is indispensable.
- Additional advice for handling sensitive Fluids: With correct material choice, all wetted parts inside the pump are made from materials appropriate for your fluid - selected types as well for food contact. A malfunction, however, might result in a contact of the fluid to components that are non-wetted during normal operation (e.g. inside the air section). Therefore, we recommend as usual for pumps, to discard the batch after a malfunction when handling sensitive fluids. Please consider that a conformity for food-contact solely refers to wetted materials themselves, NOT to a "Hygienic Pump Construction"
- Before putting the pump back into operation, the tightness of the pump has to be checked.
- Air-operated diaphragm pumps can lead to bruises when lifting, sinking or assembling them. Appropriate accessories and safety equipments are to be used. Big and heavy modules have to fixed and secured to lifting gears when transporting/replacing them.

- Especially when deliver critical liquids, wear parts, like diaphragms, should be replaced within a preventive maintenance.
- The use of non-original ALMATEC spare parts and structural changes lead to the lapse of the warranty immediately. When operating such a pump, damages of properties and/or persons cannot be excluded.



- The operation of the pump with nitrogen as driving gas is possible. In closed rooms sufficient ventilation must be provided.
- Possible electrical connections (e.g. when using optional equipment with controllers) may be executed by a qualified person only. The regulations of the respective manufacturers are to be followed.
- At any work arising it has to be made sure that no explosive atmosphere can appear. Appropriate safety equipment is recommended.
- Procedure for pump return: According to the requirements of our 14001-certification, every unit which is send to ALMATEC for diagnosis or maintenance reasons has to be accompanied by a filled out decontamination-sheet. Otherwise a processing is not possible. The decontamination-sheet is enclosed to this manual. Please pay attention to the further safety regulations.

Maintenance:

Only use original ALMATEC spare parts for repairs and / or preventive maintenance work. If this is not observed, the CE and ATEX markings, the declaration of conformity (s) and the guarantee claim for the pump will expire.

All work on the pump may only be carried out with the appropriate tools and by trained specialist personnel.

Additional temperature hints

The temperature and pressure limitations listed on page 5 are solely based on mechanical temperature limits of the housing material used. Depending on the fluid pumped, the maximum safe operating temperature of the housing material can be reduced significantly.

A general aspect of lower temperatures is, that below 0°C cold-brittling of the elastomers used within the pumps can results in accelerated wear. Regarding the housing materials, please note that PE - other than PP - keeps its mechanical strengths at low temperatures. ALMATEC pumps can therefore be operated safely as well within low-temperature installations: However, with liquids below 0°C accelerated wear of internal parts has to be accepted. Moreover, freezing, bogging or crystallisation of the fluid pumped must be avoided, especially within the pump.

Please consider, that viscosity and specific gravity of most fluids change with temperature (most often increasing at lower temperature). Depending on the application, this fact may not only result in result in a reduced flow rate, the pump may even be unable to prime the thicker and/or "heavier" fluid any more.

In case of varying application temperatures, the housing bolt tension has to be controlled very thoroughly, as variations like these can change the effective tension of the housing bolts via the different thermal expansion characteristics of single.

Disassembly

When dismantling a pump the mentioned procedures and safety notes on the previous pages have to be considered generally.

The general design of the ALMATEC AH 20/32 S is simple. A plastic tool designed for the mounting of the air-valve (29) is delivered along with every pump. Further special tools are not required. Please find the part number for any part in the spare part list.

The materials of the pump used in the following pictures can differ from the pump you have bought. So do not be concerned about different colours of the parts.

Place the pump upright with the air inlet (14) in front. Take out the muffler (16) installed onto the center block (20) before dismantling the pump to protect it against damages during the disassembly.

Loosen housing bolts (7) on the right hand and remove pump housing (1). Dismantle port extension (4), suction/discharge ports (2) and O-rings (5,6).



Remove the valve stops (3) with valve stop tube tube (3a, AH 32 only) and the ball valves [15] out of the side housings [1]. For the AH 32 the use of a screwdriver to remove the valve stops [3] maybe is more convenient.

You will now have a unit consisting of the left pump housing (1), the center block (12) and the dual stage housing (8) with the housing bolts (7) partly torn out to the left.

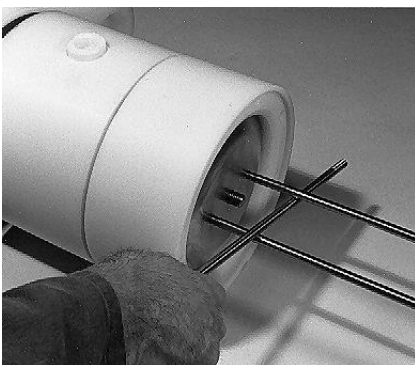

To disassemble the diaphragms (10) reach behind the right diaphragm (10) and screw it off the shaft (18). Take out the diaphragm disc (26) afterwards. Insert two long suitable screws into the threaded bores of the supporting disc (17) for approximately 10 mm. Position a round bar or a screwdriver as a handle in between them and loosen the supporting disc (do not yet screw off completely). Take the remaining housing bolts (7) out of the left pump housing (1) and remove it. Turn off the left diaphragm (10) as well.

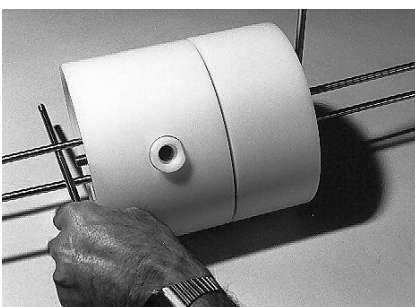

Now, a supporting disc (17) is visible on each side which can be disassembled as follows: Screw two suitable screws as well approx. 10 mm deep into the threaded bores of the on the left side hand supporting disc (17). Attach a round bar or a screwdriver in between those to unscrew the supporting disc (17) on the right and to fix the other disc. Shove the shaft (18) into the right side and unscrew the other supporting disc (17) as well. Separate the center block (12), the dual stage housing (8) and the dual stage bushing (9) with the dual stage piston (21). Screw the shaft (18) out of the dual stage piston (21). Take care not to damage the O-Ring dual stage piston (22) when disassembling the shaft (18), lead the thread through this O-ring by screwing.

The dual stage housing (8) is the smaller of both blocks in the middle of the pump. Push the dual stage piston (21) out of the dual stage bushing (9). Take out the shaft bushing, short (19). The sealing elements (20, 22, 23, 24) have to be replaced in case they are soiled or damaged.

Take the shaft bushing, long (25) out first and lay the center block (12) plainly onto a soft base (do not damage the sealing edges!).

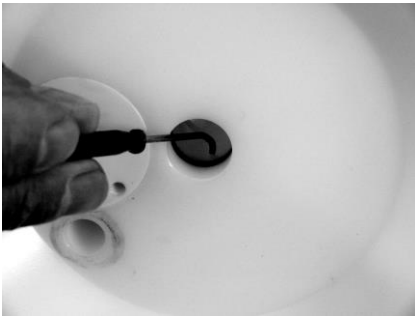

Remove both parts of the shaft piston rings (13) from their grooves carefully (do not damage the edges in the center housing) A re-assembly of the same piston rings is impossible; they have to be replaced. Handle the piston rings (13) in the dual stage housing (8) the same way.



Screw off both end caps of the *PERSWING P*[®] air control system (29) using the plastic mounting tool delivered with the pump. Take out main and pilot piston. Press out the air-valve housing with the mounting tool turned around.



To take out the air filter (15) the air inlet (14) has to be screwed off first, afterwards the filter (15) can be unscrewed easily with a big screw driver.

Hints and tips for reassembly

The re-assembly of the components is principally carried out vice-versa to the dismantling. Here are some additional references.

To install the air control system *PERSWING P*[®] (29), first screw in one end cap flushly into the center block (12). Insert one of the six O-rings air-valve housing (30) into the end cap from the inside. Moisten the four O-rings (30) of the air-valve housing with a bit of water and push the housing into the center block (12) using the mounting tool. Take care that it slips in softly. Do never insert the housing violently with a hammer. In case the housing cocks or hardly gets in, take it out again completely and start again. Insert the main piston and the pilot piston. Lay the sixth O-Ring (30) on the edge of the air-valve housing and screw in the second end cap.

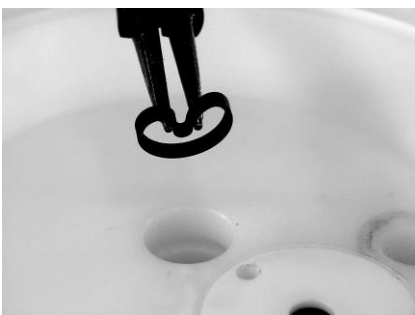

Installation of the shaft piston ring (13) into the center block (12): The O-Rings located underneath the piston rings (13) have to be installed first. A re-assembly of the used piston rings is impossible; they have to be replaced! To assemble piston rings (13), carefully shape them like kidneys with locking ring pliers and insert the rings into the grooves; completely press the rings into the grooves smoothly using a clean housing bolt (7). Insert the shaft bushing, long (25) on side of the center block where the big O-ring dual stage bushing (24) is located.

Install piston rings (rings and O-Rings, 13) into the dual stage housing (8) as described. Insert the shaft bushing, short (19) on the side of the big O-Ring dual stage bushing (24). Lay the dual stage bushing (9) into the dual stage housing (8) and afterwards insert the dual stage piston (21) with the conic side at first into the dual stage bushing (9).

Put together the center block (12) and the dual stage housing (8) and the shaft (29) has to be shoved in rotatingly with care. The threads on both sides of the shaft differ in their lengths. Screw the first supporting disc (17) onto the shaft (18) up to its block at the side where the thread is the shorter. Attach the other supporting disc (17) tightly on the other end and tighten the first disc as well (for tightening the discs, follow the disassembly instructions). Take the screws used for fixing out of the supporting discs (17). Align the bore holes in center block (12) and dual stage housing (8). Put on the diaphragm discs (26) on both sides.

Screw a diaphragm (10) on one side onto the shaft (18) until it blocks. Take care that the bore holes for the housing bolts are aligned between the diaphragm (10), the center block (12) and the dual stage housing (8). Insert three housing bolts (7) carefully as an assembly auxiliary. Push the diaphragm (10) into the center block (12) resp. dual stage housing (8) as far as possible. Screw the second diaphragm (10) up to its block onto the other end of the shaft (watch out for all bores to be aligned, if necessary, slightly turn back the diaphragm). Shove in the remaining housing bolts (7) finally.

The sealing surfaces of the diaphragms (10) and the pump housings (1) have to be absolutely clean and undamaged; mere small scratches can cause leaking.

Insert the inner O-rings (5) in the manifolds (2) and the port extensions (4) carefully (bending the rings absolutely has to be avoided! Moisturising the rings and twisting them carefully may be helpful). Mount the outer O-rings (6) onto the ledges of the pump housings (1) and the port extensions (4).

Shove one of the already mounted diaphragms (10) into the center block (12), lay on a pump housing (1) and fix the position with the housing bolts (7). Push the second diaphragm (10) into the center block (12) and insert the housing bolts (7) carefully (if necessary, rotate the bolt smoothly while pushing) through the bore holes of the diaphragm without damaging the diaphragm and its surfaces. Set the manifolds (2) and the port extensions (4) on the pump housing. Adjust the second pump housing (1). Fix the housing bolts (7) crosswise evenly according to the given torque values until the pump housings (1) are situated on the center block (12). Any further tightening of the bolts does not improve sealing but can deform the housing!

Before putting the pump back into operation, the tightness of the pump has to be checked.

In case the flow rate of the pump decreases after some time of operation without any obvious reason, this is frequently due to a muffler blocked by heavily soiled driving air: take out the muffler (16) and replace it, if necessary; clean the air-valve carefully without any solvents and install an air filter to clean the driving air before entering the pump.

Optional equipments (not part of the standard scope of delivery)

- Stroke counting (option code C)

A sensor integrated in the center block (12) of the pump to monitor the movement of a diaphragm (10) without direct contact.

The stroke counting system is available in four variations:

- C 2 Stroke sensor (Namur), also for explosion proof zone
- C 3 Stroke counting system complete with sensor and stroke counter
- C 4 Stroke counting system complete with sensor, stroke counter and controller for explosion proof zone

In case only the sensor is included (code C 2), it has to be connected to an existing controller. For applications an explosion-proof device is required for (code C 4) the intrinsically safe controller has to be installed between the sensor and the counter. The wiring diagram and technical data can be found on the electric units themselves.

For further details, please refer to the data delivered by the manufacturers of the components.

- Diaphragm monitoring system (option code D)

A capacitive diaphragm sensor is mounted in the muffler (16) of the pump, which registers any liquid approaching the sensor, no matter whether the liquid is conductive or not. Hence, a fast reaction to a damage of a diaphragm becomes possible. However, it has to be considered, that the diaphragm monitoring possibly cannot prevent that liquid can leave the pump via the muffler. In case of humid surrounding air a false alert may occur despite operating the pump with dried compressed air.

The diaphragm monitoring system is available in two variations:

- D 1 Diaphragm sensor (Namur), also for explosion proof area
- D 3 Diaphragm monitoring system complete with sensor and controller

The diaphragm sensor can either be connected to an existing controller (code D 1) or to the controller included (code D 3). The wiring diagram and technical data can be found on the controller itself.

For further details, please refer to the data delivered by the manufacturers of the components.

Troubleshooting

Malfunction	Possible Reason	Solutions/Remarks
pump does not operate	air supply line blocked/closed muffler blocked working chambers blocked air control system defective discharge line blocked/closed	open air supply clean/replace muffler remove blockage replace air valve system clean/open line
pump operates unsteadily	piston rings worn air control system worn diaphragm rupture air control system soiled check valve blocked icing	replace piston rings replace air control system replace diaphragm, clean pump clean/replace air control system cleaning, removal of bulk particles improve air processing
air within liquid	suction line leaky container with liquid empty diaphragm rupture cavitation	seal suction line fill/new container replace diaphragm adapt suction lift, possibly install suction pressurised air chamber
insufficient discharge pressure	insufficient pressure/amount of driving air air supply line leaky air control system leaky check valve worn more air consuming components	increase air supply check/repair air supply replace air control system check/replace check valve increase pressure/amount of air
output decreases	air control system soiled icing air pressure drop suction line/inlet strainer soiled discharge line/outlet strainer soiled muffler blocked check valve worn change in viscosity more air consuming components	clean/replace air control system improve air processing: dryer/filter ensure sufficient supply of air cleaning cleaning replace the muffler replace valve change back/adjust pump increase pressure/amount of air
pump stops itself	icing of the air control system air pressure too low air pressure drop discharge line blocked air filter blocked valve closed air control system defective wear/leaking of air control system diaphragm rupture check valve blocked/worn	improve air processing: dryer/heater etc. increase air pressure ensure sufficient air supply clean discharge line clean air filter open valve replace air control system replace air control system replace diaphragm, clean pump clean/replace check valve

Malfunction	Possible Reason	Solutions/Remarks
pumps operates, however suction capacity insufficient	<p>pump operates too fast operation beyond physical limits cavitation operation beyond pump capacity</p> <p>air cushion within suction/discharge line dry suction against discharge pressure valve filter within suction line closed valve filter within discharge line closed container with liquid empty vacuum inside the container wear of the check valves suction line leaky suction line blocked air pressure cushion at discharge check valve blocked</p>	<p>start more slowly adjust installation check, cool down adjust installation resp. install bigger pump bleed the line</p> <p>wet pump, start without pressure</p> <p>open valve/clean filter open valve/clean filter</p> <p>fill/new container bleed container replace valves seal suction line clean suction line bleed discharge line clean/replace valve</p>
insufficient suction capacity after pump repair	<p>connections tighten incompletely check valves inserted falsely</p>	<p>tighten/seal connections correct positioning of check valves</p>
diaphragm overstrained	<p>pressure within the plant/system</p> <p>inadmissible vacuum icing</p>	<p>ensure that pressure is only developed by the pump itself, check plant/valves, replace diaphragms check suction line, open valve improve air processing</p>
leaking between housing parts	<p>housing bolts loosened O-rings sleeve damaged diaphragms attacked chemically diaphragms overstrained tension installation/pipework</p>	<p>tighten bolts, check pump replace O-rings replace diaphragms replace diaphragms loosen, eliminate tension, use of a compensator</p>
muffler grey	driving air too humid, icing	improve quality of driving air
muffler black	soiled, oily air	improve quality of driving air, install sensitive filter in suction line
pump is connected to air but does not operate	<p>air control system blocked bulk particles/dirt</p> <p>chemical influence (O-rings swollen) valve closed in discharge line</p>	<p>clean/replace air control system clean pump, replace necessary parts, improve air quality check, replace damaged parts</p> <p>open valve</p>
liquid leaves the pump via the muffler	diaphragm rupture	replace diaphragms, clean pump

Exploded view

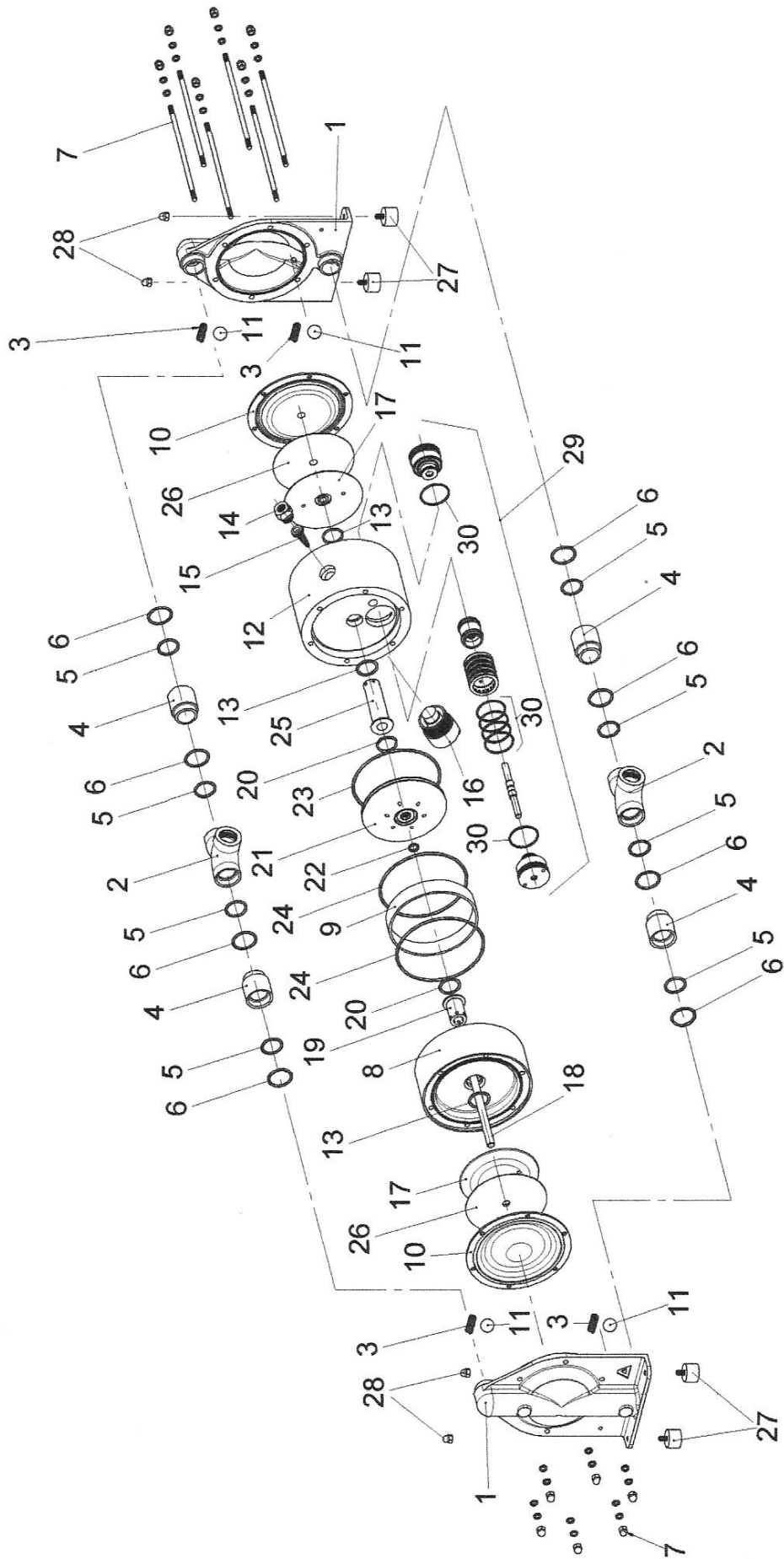

Spare part list

Pump size				AH 20 S	AH 32 S
Item	Pc.	Description	Material	Part number	Part number
1	2	Pump housing	1.4408	5 20 210 26	5 32 910 26
2	2	Suction/discharge port (BSP)	1.4408	5 20 011 26	5 32 011 26
3	4	Valve stop	1.4571	5 20 216 24	5 32 216 24
3a	4	Valve stop tube	PTFE	-	5 32 217 60
4	4	Port extension	1.4571	5 20 213 24	5 32 213 24
5	8	O-ring, ports, inside (code STT)	PTFE	9 24 537 60	9 36 539 60
	8	O-ring, ports, inside (code SEE)	EPDM	9 24 537 72	9 36 539 72
6	8	O-ring, ports, outside	EPDM	9 28 512 72	9 42 540 72
7	6	Housing bolt, cpl.	1.4301	5 20 220 22	5 32 220 22
8	1	Dual stage housing	PE conductive/Alu	3 15 248 56	3 25 248 39
9	1	Dual stage bushing	PETP	3 15 049 84	3 25 049 84
10	2	Heavy duty diaphragm (code STT)	PTFE/EPDM	3 15 131 67	3 25 131 67
	2	Heavy duty diaphragm (code SEE)	EPDM	3 15 131 72	3 25 131 72
11	4	Valve ball (code STT)	PTFE	1 15 032 60	1 25 032 60
	4	Valve ball (code SEE)	EPDM	4 20 032 72	1 25 032 72
12	1	Center block	PE conductive	3 15 540 56	-
	1	Center block	Alu	-	3 25 540 39
13	3	Shaft piston ring, cpl.	PTFE	1 40 041 64	1 50 041 64
14	1	Air inlet	PETP	1 15 047 84	1 40 047 84
15	1	Air filter	PE	1 15 043 51	1 40 043 51
16	1	Muffler	PE	1 15 244 51	1 40 244 51
17	2	Supporting disc	AL	3 15 033 31	3 25 033 31
18	1	Shaft	1.4301	3 15 030 22	3 25 030 22
19	1	Shaft bushing, short	1.4301	3 15 035 22	3 25 035 22
20	2	O-ring, shaft bushing	NBR	9 24 514 71	9 30 510 71
21	1	Dual stage piston	Alu	3 15 034 31	3 25 034 31
22	1	O-ring, dual stage piston	FKM	9 10 507 74	9 12 506 71
23	1	Piston ring, cpl.	PE	3 15 037 52	3 25 037 52
24	2	O-ring, dual stage bushing	NBR	9 99 567 71	9 99 562 71
25	1	Shaft bushing, long	1.4301	3 15 036 22	3 25 036 22
26	2	Diaphragm disc	PTFE	3 15 039 60	3 25 039 60
27	4	Shock absorber	NR	1 15 022 85	1 15 022 85
28	4	Nut	1.4305	9 06 106 22	9 06 106 22
29	1	PERSWING P® air control system, cpl.	PETP	2 15 001 84	2 40 001 84
30	6	O-ring, air valve housing (included in item 29)	NBR	9 35 504 71	9 46 515 71

Optional equipment

Item	Pc.	Description	Material	Part number	Part number
Code C2: Stroke counting					
12	1	Center block for sensor	PE conductive/Alu	3 15 640 56	3 25 640 39
-	1	Stroke sensor, Namur	diverse	1 00 072 99	1 00 072 99
Code D1: Diaphragm monitoring					
51	1	Diaphragm sensor, Namur	diverse	1 00 773 99	1 00 773 99
Code N:					
2	2	Suction/discharge port (NPT)	diverse	5 20 711 26	5 32 711 26

Dimensions

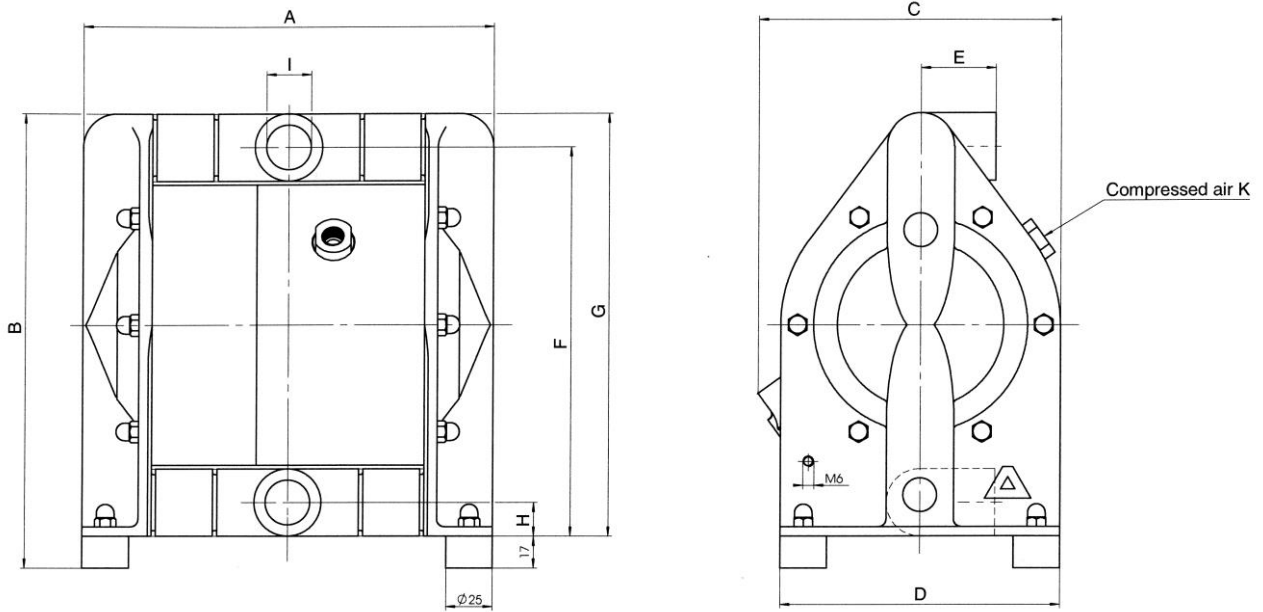

<i>mm</i>	A	B	C	D	E	F	G	H	I	K
AH 20 S	220	243	162	150	40	208	226	18	3/4" BSP/NPT	1/4" BSP
AH 32 S	324	327	229	200	52	284	310	26	1-1/4" BSP/NPT	1/2" BSP

<i>inch</i>	A	B	C	D	E	F	G	H	I	K
AH 20 S	8.66	9.57	6.38	5.91	1.57	8.19	8.9	0.71	3/4" BSP/NPT	1/4" BSP
AH 32 S	12.76	12.87	9.02	7.87	2.05	11.18	12.2	1.02	1-1/4" BSP/NPT	1/2" BSP

Notes



Subject to change without notice, 2021/07

PSG Germany GmbH
Hochstraße 150-152 · 47228 Duisburg · Germany
Telephone +49 (0) 20 65 / 89 2 05 - 0 · Telefax +49 (0) 20 65 / 89 2 05 - 40
<http://www.psgdover.com> · e-mail: psg-germany@psgdover.com