

OPERATING AND INSTALLATION INSTRUCTIONS



**Air-Operated Double
Diaphragm Pumps
made of Plastic**



**C-Series
C 10 - C 50**



Original Instruction
Read carefully before pump installation

CONTENTS

	page
Introduction	3
General description of the machine, appropriate use and residual dangers	3
Storage and long-term usage	3
Code system	4
Operation in explosion proof areas	5
Special Operations Conditions	5
Atex Marking for Gases and Dusts in Accordance to 2014/34/EU	6
Technical data	7
Performance charts	7
Installation	
Recommended installation	9
Product ports	10
Startup operations	10
Torque values	11
Safety instructions	12
Using as submersible pump	13
Additional temperature hints	13
Providing spare parts	13
Maintenance	
Required tools	14
Disassembly	14
Assembly	16
Trouble shooting	17
Spare part lists	
C 10 Code EEE – UVT	19
C 15 Code EEE – UVT	20
C 25 Code EEE – UVT	21
C 40 Code EEE – UVT	22
C 50 Code EEE – UVT	23
Exploded View	
C-series	24
Optional equipment	
Stroke counting (Code C)	25
Diaphragm monitoring (D)	26
Pumps with PTFE-diaphragms and FEP gaskets (FP)	27
Center block made of PA-conductive	27
NPT-threaded air inlet (AN)	27
Dimensional Drawing	28

INTRODUCTION

ALMATEC air-operated diaphragm pumps are constructed according to the state of the art and they are reliable. Imminent danger by operating error or misuse can lead to damages of properties and/or persons. The pumps are to be applied for the intended use and in a safety-related proper condition only.

Each person working on the ALMATEC air-operated diaphragm pumps concerning installation, start-up, handling or maintenance must read this manual completely and in an attentive way and has to follow all mentioned procedures and safety notes.

General description of the machine, appropriate use and residual dangers

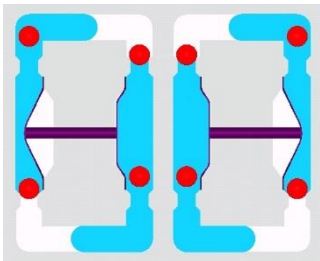

The ALMATEC air-operated double diaphragm pumps are oscillating positive displacement pumps and are based on the functional principle of double diaphragm pumps. The basic configuration consists of two external side housings with a centre housing between them. Each of the side housings contains a product chamber which is sealed against the centre housing by a diaphragm. The two diaphragms are interconnected by a piston rod. Directed by an air control system, the diaphragms are alternately loaded with compressed air so that they move back and forth. In the first figure, the compressed air has forced the left-hand diaphragm towards the product chamber and displaced the liquid from that chamber through the open valve at the top to the discharge port. Liquid is simultaneously drawn in by the right-hand diaphragm, thus refilling the second product chamber. When the end of the stroke is reached, it reverses automatically and the cycle is repeated in the opposite direction. In the second figure, liquid is drawn in by the left-hand diaphragm and displaced by the right-hand diaphragm.

The appropriate use of an Almatec air-operated diaphragm pump refers to the liquid transport considering the operation parameter mentioned in this manual and in compliance of the given terms for commissioning, operation, assembly, disassembly and maintenance.

Even if all necessary safety measures described in this manual have been met, a residual danger exists by leakages or mechanical damages. At sealing areas or connections liquid can be released uncontrollably then.

Storage and long-term usage

In general, the ALMATEC pump is delivered operational and packaged. If the unit is not installed right away, proper storage conditions are important for a trouble-free operation later. The pump has to be protected from wetness, coldness, dirtying, UV-radiation and mechanical influences. The following storage conditions are recommended:

- Steady ventilated, dust and vibration free storage room
- Ambient temperature between 15°C (59°F) and 25°C (77°F) with a relative humidity below 65%
- Prevention of direct thermal influences (sun, heating)

Plastic materials are subject to aging processes depending on material, surrounding conditions and application parameters. Chemical contact and/or increased temperature can amend material characteristics on the long run, especially mechanical capabilities. For safety reasons, we do therefore recommend as part of every maintenance (resp. in case of no maintenance till then after two years and then every six month): A careful visual check of all pump parts for visible damages, a tactile check of all sealing surface (e.g. by moving a finger along the surface after cleaning), a shape-check of the housing parts (e.g. by laying a drawer on plain surfaces) and a movability check of all threads. Any eventually damaged part needs to be replaced!

CODE SYSTEM

PSG Germany GmbH is certified as a modern, quality-orientated enterprise acc. to DIN EN ISO 9001 and 14001. Before release for dispatch, any ALMATEC pump must undergo an extended final control. The performance data registered during this are archived in our records and can be read back at any time.

As a general rule in the countries of the EU only such machines are allowed to take into operation, which are determined to meet the regulations of the EU machinery directive, the harmonized standards, European standards and the respective national standards. Hence the operator has to verify whether the ALMATEC pump manufactured and delivered properly according to the customer's order meets the mentioned requirements. Therefore, make sure before putting the pump into operation, that the pump and the used materials of construction are suitable for the provided application and the installation site. To check this, the exact pump code is required. This code, the serial number and the year of construction are noted on the identification plates on the pump itself. Example to clarify the ALMATEC pump code:

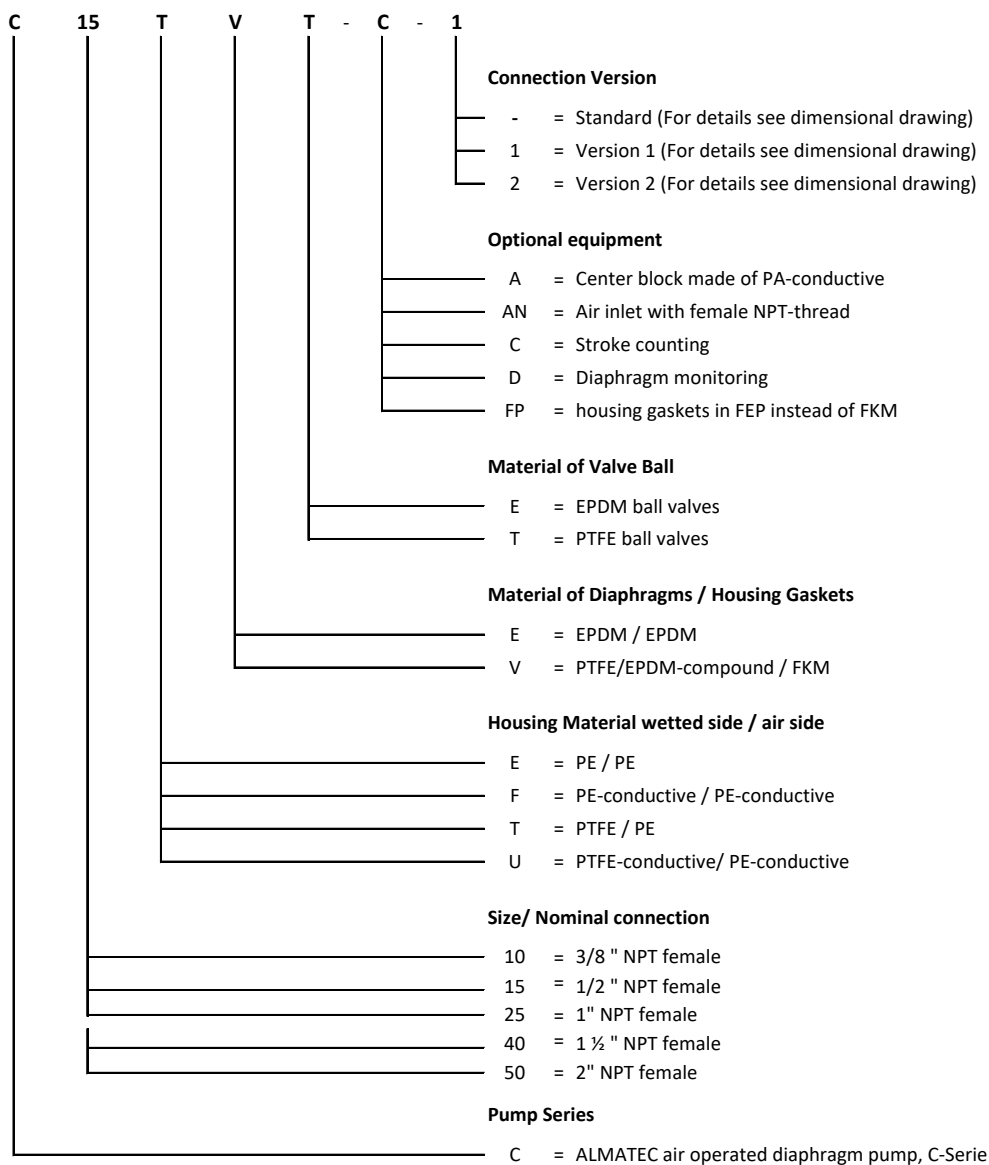

The number in brackets, which is added to every part mentioned in the following explanations, refers to its position in the spare part list and the exploded view.

OPERATION IN EXPLOSION-PROOF AREAS AND FOR FLAMMABLE LIQUIDS

X = CAUTION! = Special operating conditions apply!



For pumping flammable liquids or in Ex-areas, only pumps with housing parts and internals made of conductive plastic may be used. Air-operated diaphragm pumps of the C series with housing codes F (PE conductive) and U (PTFE conductive) meet this requirement. They must generally be grounded via a connection on the side housing [1]. The ground connection must have a minimum cross-section of 6 mm². All other housing parts are conductive and connected to each other.

ALMATEC air-operated diaphragm pumps made of electrically conductive PE/PTFE are suitable for use in potentially explosive atmospheres of category 2 and 3 ("Zone 1" and "Zone 2" respectively), atmosphere G/D, which are subject to the scope of EU Directive 2014/34/EU. Conductive diaphragms (material code 68, 70, 72) can be used without restriction for pumping liquids in all explosion groups. If non-conductive diaphragm materials are used (material code 67, 98), explosion group IIB applies within the pump for pump size C 10 up to including C 25 (regardless of the installation site). Following protective measures must be taken for pump size C 40 and C 50 as examples:

- exclusive use of water-miscible or conductive pump media or
- Avoidance of dry running through operational measures or
- inerting during dry running with nitrogen, water, carbon dioxide, etc. following the pumping operation.

Pipelines and product connections must be grounded separately. To avoid ignition hazards, the formation of dust deposits on the units must be prevented. Repairs in hazardous areas may only be carried out after careful examination of the feasibility and only with appropriate tools and by trained specialist personnel.

The ATEX marking according to Directive 2014/34/EU can be found in the enclosed Declaration of Conformity and the corresponding sticker on the pump or damper.

The interfaces for electrical accessories have been considered and do not represent a new potential ignition source.

The type of protection "c = design safety" was applied in accordance with guideline EN ISO 80079-37.

Special operating conditions	C 10	C 15	C 25	C 40	C 50
Permitted ambient temperature °C (°F)	-10 – 50 (14 – 122)				
Permitted temperature of driving air °C (°F)	0 – 50 (32 – 122)				
Maximum operating / driving air pressure bar (psi)	7 (101)				
Maximum operating temperature (X)					
PE pumps °C (°F):	70 (158)	70 (158)	70 (158)	70 (158)	70 (158)
PTFE pumps °C (°F):	80 (176)	80 (176)	80 (176)	80 (176)	80 (176)
PTFE pumps with center block in PA-conductive °C (°F):	100 (212)	100 (212)	100 (212)	100 (212)	100 (212)

ATEX MARKING FOR GASES AND DUSTS IN ACCORDANCE TO 2014/34/EU

In order to enable the optimum and flexible design of an ATEX pump to the customer-specific application, a differentiation is made in the marking between the installation location of the pump (hazardous area outside the pump) and the inside of the pump (hazardous area inside the pump).

Equipment category G (gases, mists, vapors)

Installation site: Category G

Inside the pump: Category G

Conductive ALMATEC air-operated diaphragm pumps may generally be used in explosion group IIC at the installation site (potentially explosive area outside the pump), since the solid housings are made of dissipative materials and the entire pump is grounded.

ATTENTION! Inside the pump, the permitted explosion group varies depending on the diaphragm material used:

When using *non-conductive diaphragms*, explosion group IIB applies inside the pump:

⊕ II 2/2 G Ex h IIB/IIC T6...T4 Gb/Gb X (inside the pump/installation site)

When using *conductive diaphragms*, explosion group IIC applies inside the pump:

⊕ II 2/2 G Ex h IIC/IIC T6...T4 Gb/Gb X (inside the pump/installation site)

Equipment category D (dusts)

Installation site: Category D

Inside the pump: Category G

Conductive ALMATEC air-operated diaphragm pumps may generally be used in dust group IIIC at the installation site (potentially explosive area outside the pump; equipment category D).

ATTENTION! Inside the pump (equipment category G), the approved explosion group varies depending on the diaphragm material used:

When using *non-conductive diaphragms*, explosion group IIB applies inside the pump:

⊕ II 2/2 D Ex h IIB/IIIC T 70°C...130°C Gb/Db X (inside the pump/installation site)

When using *conductive diaphragms*, explosion group IIC applies inside the pump:

⊕ II 2/2 D Ex h IIC/IIIC T 70°C...130°C Gb/Db X (inside the pump/installation site)

TECHNICAL DATA

TECHNICAL DATA		C 10	C 15	C 25	C 40	C 50
Dimensions – mm (inch):	Length	110 (4.3)	156 (6.1)	206 (8.1)	272 (10.7)	352 (13.8)
	Width	155 (6.1)	203 (8.0)	273 (10.8)	368 (14.5)	452 (17.7)
	Height	179 (7.1)	253 (10.0)	353 (13.9)	453 (17.8)	567 (22.3)
Nominal port size (NPT)		3/8"	1/2"	1"	1 1/2"	2"
Air inlet (BSP)		R 1/8	R 1/4	R 1/4	R 1/2"	R 1/2"
Weight -kg (lbs.):	PE	2 (4.4)	6 (13.2)	14 (30.9)	30 (66)	57 (126)
	PTFE	4 (8.8)	10 (22.1)	23 (50.7)	57 (126)	104 (229)
Max. particle size of solids – mm (inch) for pumps with ball valves		3 (0.12)	4 (0.16)	6 (0.24)	9 (0.35)	11 (0.43)
Suction lift, dry – mWC (ftWC):		1 (3.3)	2 (6.6)	3 (9.8)	4 (13.1)	5 (16.4)
Suction lift, wetted – mWC (ftWC):		9 (29.5)	9 (29.5)	9 (29.5)	9 (29.5)	9 (29.5)
Theoretical displacement volume per single stroke – l/min (gpm)		22 (6)	52 (14)	117 (31)	390 (100)	695 (185)

The data listed refer to standard C-Series-pumps without optional equipment.

PERFORMANCE CHARTS

The data refer to water (20°C/68°F), under using of different variations (e.g. ball valve model, damper preparation etc.), a compressor Atlas Copco VSG30 and calibrated measuring equipment. The specified performance data are warranted by ALMATEC in accordance with DIN EN ISO 9906.

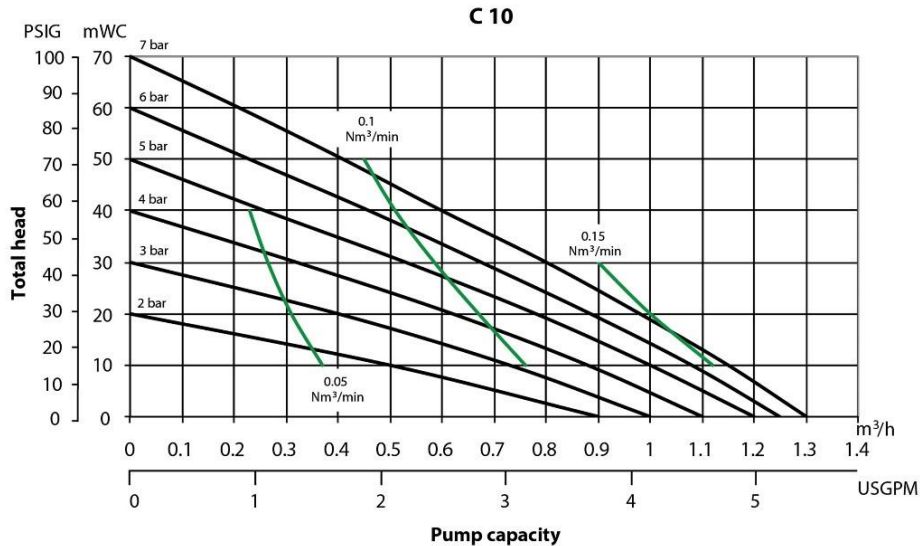

C 15

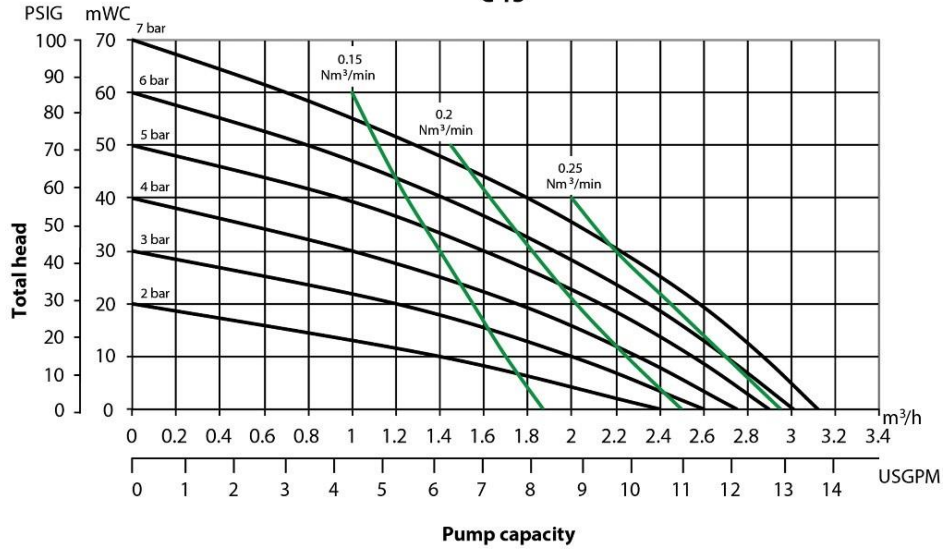

C 25

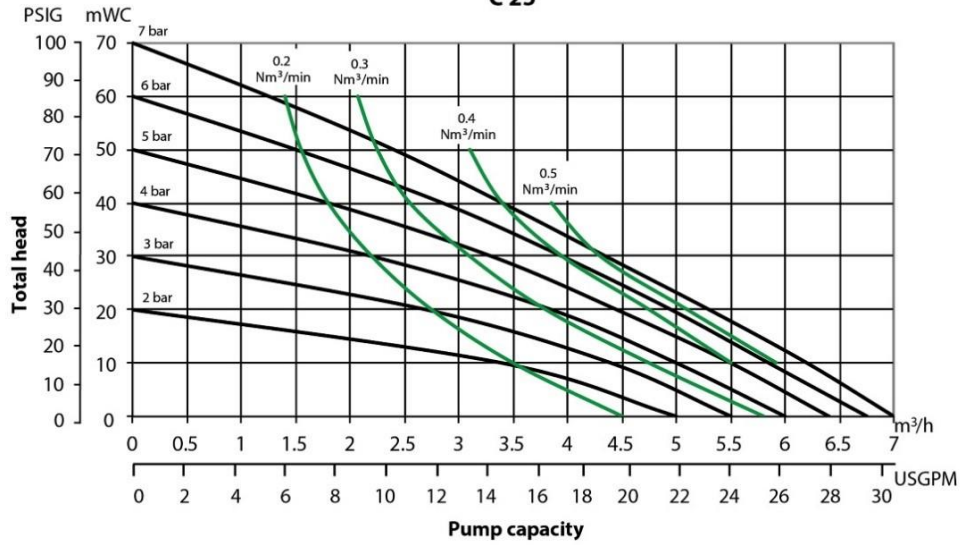

C 40

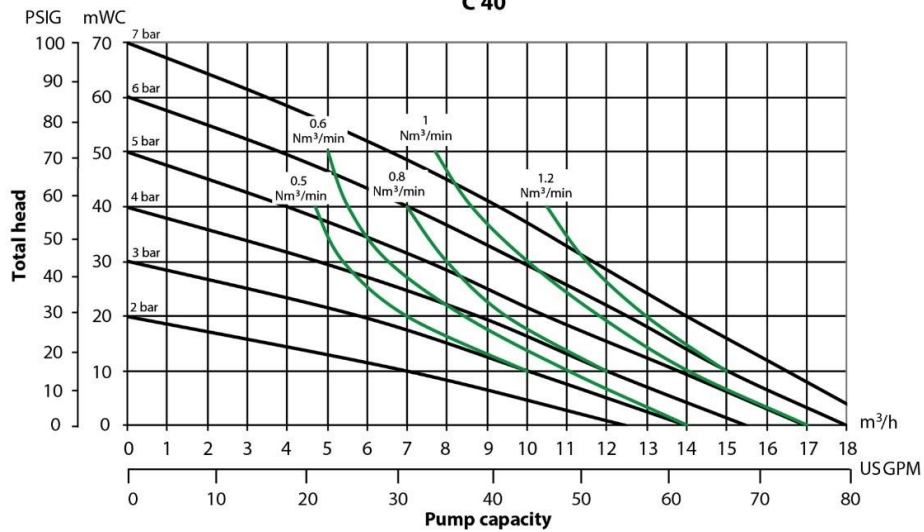

C 50

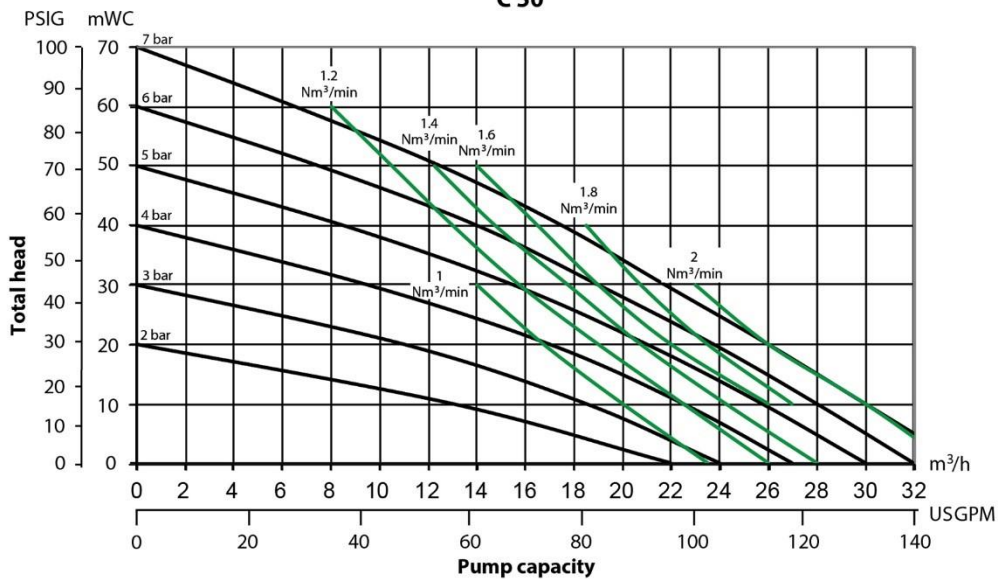

INSTALLATION

Recommended Installation

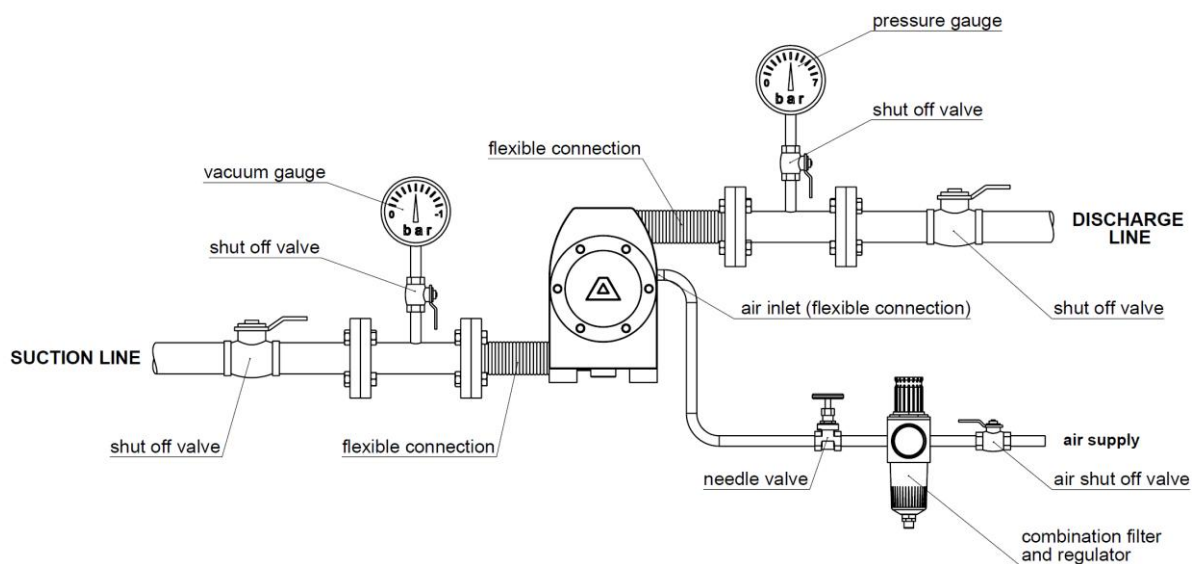

Product ports

The product ports are integrated into the discharge manifold [11] at the upper end and the suction manifold [12] at the lower end of the pump. The manifolds are not rotatable. At delivery, C-Series-pumps come with suction inlet and discharge outlet opposite to each other, both horizontal (Illus. 8.1).

If necessary, it is after taking off the side housings [1] possible to install one of the manifolds the other way round so that inlet and outlet are positioned on the same side.



Abb. 8.1

Startup operations

UV-radiation and elevated temperature by UV-radiation can damage the housing parts of pumps made of PE (material code E and F). In general, the pump has to be connected load free. Neglecting this causes leakage and maybe even damages. To avoid vibrations and temperature related dimension changes in piping systems, pulsation dampers and compensators are recommended. Before connecting the pump, take the yellow blind plugs out of the suction and discharge manifolds [11/12] as well as the air inlet [17]. The air inlet is located below the bilingual sticker with safety instructions. The connections of ALMATEC air-operated diaphragm pumps made of plastic have slightly tapered threads. Use thread seal only sparingly, otherwise the connections could be damaged.

The operator is responsible for an adequately stability and an appropriate fixation of the piping according to the state of the art. To facilitate the installation and maintenance shut off valves should be installed right before and after the pump. The nominal width of the connection pipes has to be chosen in accordance to the connections of the pump. A smaller piping can cause cavitation (suction line) as well as a loss of performance (suction and discharge line). In case the pipe is too big, the dry suction capacity of the pump can decrease. Connect the suction line to the suction manifold [12]. Seal the suction line diligently; hosepipes should be suitably armored. A suction line continuously rising will prevent the formation of air locks in the line which would affect the suction lift.

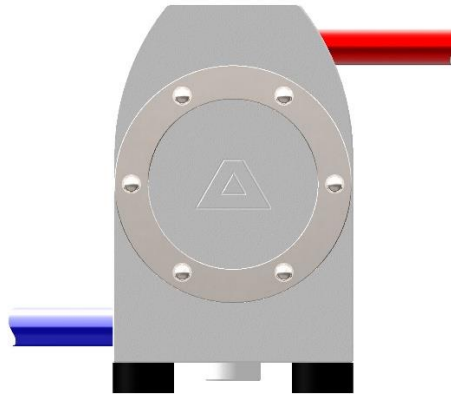
The air inlet [17] is located in the middle of the center block [15]. At delivered, it is covered by a bilingual sticker with safety instructions, which can be easily removed. Before installation, make sure that the air supply pipe is free of solids. To supply the pump with driving air sufficiently, the pipe diameter should match the size of the air inlet. Take care that no dirt or particles can intrude into the pump during the connection, as these can accumulate inside the pump and can cause malfunctions.

The integrated air control system *PERSWING P*® [16] is a precision-control that requires oil-free, dry and clean compressed air for optimal function. If humidity is expected, a water separator or air dryer has to be fitted to protect the pump from blocking by ice. The ideal condition is the dewpoint of air at -20°C (-4°F). In humid surroundings, icing from the outside may occur despite the driving air is dried. If so, a prolonged waste-air-exhaust (ca. 500 mm / 20 inch by pipe or hose) can be helpful. When installing the pump into boards or cabinets, it has to be ensured that cold air does not get caught behind the muffler. In applications with a

tendency to freezing at the waste air exhaust, good experiences in practise have been achieved by pre-heating the driving air to increase the distance to the dew point of the air. Doing so, it has to be considered that the driving air temperature generally may not exceed 50°C (122°F) to avoid expansion and sticking effects on the air side. This maximum air temperature is a well valid when using a compressor producing warm air which is e.g. often true for truck compressors.

The pressure of the driving air should be limited to the amount required to meet the performance needed. Excessive pressure increases both the air consumption and the wear of the pump. The pump is regulated by tuning the flow rate of the air. For a proper operation at the lower performance range the regulation via a needle valve is recommended. An empty pump has to be driven slowly (e.g. via a needle-valve). The pump starts automatically. Pumps of the C-Series are self-priming when dry, thus it is not necessary to fill the suction line of the pump. During slow operation of the pump the dry suction lift is better than during high stroke frequency. The suction lift capacity of a liquid-filled pump, however, is much higher.

The pump is appropriate for running dry during slow operation. Dry running at high stroke frequency causes premature wear. The pumps can briefly (up to max. one hour) be operated against a closed discharge line. Throttling on the suction side may damage the pump. When the pump operation has been stopped by a closed discharge, the pressure equilibrium of the diaphragms must be ensured. This can be achieved by keeping the pump connected to the air supply pressure; for longer stoppage, the pump must be released from the pressure within the system on both fluid side and air supply side.

Torque values



Immediately before putting the pump into operation as well as after some hours of pumping, the housing bolts [23] have to be fixed according to the torque data listed below. The valve stops discharge valve [2] and the plugs [8] have to be fixed too, as the elements of construction "settle" as well. As a reminder the air inlet [17] is covered by a corresponding sticker at delivery condition. Fixing all these parts is necessary as well after stoppage periods, at temperature variations, after transport and dismantling the pump. In case of temperature varying between extremes or high temperature difference between the liquid and the surrounding, the housing bolts should be controlled more frequently (interval proposals are available on request). The following schedule shows the recommended torque values of the pump housing bolts:

Size	C 10	C 15	C 25	C 40	C 50
Torque values for pump housing bolts – Nm (ft lbs):					
PE-pumps	5,5 (4.1)	8,5 (6.3)	14 (10.3)	18 (13.3)	23 (17)
PTFE-pumps	4,5 (3.3)	6,5 (4.8)	11 (8.1)	15 (11.1)	19 (14)

Safety instructions



- Installation, operation, and maintenance by qualified staff only.
- Before start-up of the pump anyone should acquaint oneself with the explanations of the chapter troubleshooting (see page 15). Only by this the defect quickly can be realized and eliminated in case of trouble. Problems which cannot be solved or with an unknown reason should be passed on to the manufacturer.
- Before any maintenance and service procedures arising on the pump or on the optional equipment, the complete installation has to be turned off and protected against accidental turn on. This is possible by a lockable emergency stop for the air supply of the pump. Additionally a danger sign against restart should be attached.
- Pressure tests of the plant a pump is included in may only be carried out with the pump disconnected from the pressure on both ports or by using the pressure the pump develops while operating. The load of a pressure in the plant may damage the pump.
- AODD pumps must not be operated with a positive suction pressure.
- Depending on the conditions of operation, the liquid conveyed might escape from the pump through the muffler in case of a diaphragm rupture (in this case muffler has to be replaced). For further safety requirements the optional equipment diaphragm monitoring and barrier chamber system are recommended.
- In case of a diaphragm rupture, it might be possible for the fluid pumped to intrude into the air side of the pump. In very adverse conditions - e.g. pressure within the fluid system during stopped air supply - the fluid might as well find its way into the air supply lines. To protect other devices like pulsation dampers or even pneumatic valves, it is recommended to protect the air supply line accordingly, e.g. via a non-return valve. This would as well avoid polluting the air supply line.
- The state of the muffler has to be inspected regularly, as a blocked muffler can be forced out of the pump. If this happens, damages of properties and/or persons cannot be excluded
- If the product tends to settle, the pump has to be flushed regularly. For larger solids a filter has to be installed in the suction line.
- In case of delivery of hot liquids the wetted pump must not standstill for a longer time, because it could lead to temporary leaks in the valve area and to a blockade of the air control system.
- The relevant effective security advises have to be respected.
- Pools of liquid which appear in the near outer area of the pump have to be inspected on danger potential, if necessary safety measures are to be taken.
- Chemical and biological reactions in the product chamber of the pump (mixture of different substances) and the freezing of the liquid have to be avoided.
- Before starting to disassemble the pump, take care that the pump has been emptied and rinsed. Both ports piping are to be closed and drained if applicable. Further the pump has to be cut off from any energy on the air and product side. If the pump is being deported from the plant, a reference about the delivered liquid has to be attached. A template is available on the Almatec website.
- Please respect the relevant additional security advises, if the pump has been used for aggressive, dangerous or toxic liquids (e.g. suitable protective equipment according to the safety data sheet of the liquid). In case of a diaphragm rupture, it is possible that residues of the liquid remain behind the diaphragms, in the area of the air control system and at the muffler, despite of several flushing processes. Hence, appropriate safety equipment according to the safety data sheet of the liquid is indispensable.
- Before putting the pump back into operation, the tightness of the pump has to be checked.
- Air-operated diaphragm pumps can lead to bruises when lifting, sinking or assembling them. Appropriate accessories and safety equipment are to be used. Big and heavy modules have to be fixed and secured to lifting gears when transporting/replacing them.
- Especially when deliver critical liquids, wear parts, like diaphragms, should be replaced within a preventive maintenance.
- The use of non-original ALMATEC spare parts and structural changes lead to the lapse of the warranty immediately. When operating such a pump, damages of properties and/or persons cannot be excluded.
- The operation of the pump with nitrogen as driving gas is possible. In closed rooms sufficient ventilation must be provided.
- Possible electrical connections (e.g. when using optional equipment with controllers) may be executed by a qualified person only. The regulations of the respective manufacturers are to be followed.



- At any work arising it has to be made sure that no explosive atmosphere can appear. Appropriate safety equipment is recommended.
- The pump is tested with water before shipment. Water residues inside the pump cannot be precluded. If the liquid, which is wanted to be conveyed, potentially interacts with water, please consult Almatec.
- Procedure for pump return: According to the requirements of our 14001-certification, every unit which is send to ALMATEC for diagnosis or maintenance reasons has to be accompanied by a filled out decontamination-sheet. Otherwise a processing is not possible. The decontamination-sheet is enclosed to this manual. **Please pay attention to the further safety regulations.**

Using as submersible pump

Consider the following advises when using a C-Series pump as a submersible pump: When immersing an air-operated diaphragm pump, it must generally be ensured that the waste air is deducted above the fluid level with a pipe or similar. The pump must be located vertically upright to guarantee proper function. Minute leakage on the air inlet or outlet can block the air valve. The pump must be disconnected from the pressure within the system during standstill. When choosing the pump type, it must be taken into consideration that all external parts - even those non-wetted during standard operation - like covers, shock absorbers, connections etc. must be resistant to the fluid pumped. Please consider as well that depending on the material, the pump must be weight down resp. fixed.

Additional temperature hints

The temperature and pressure limitations listed on page 5 are solely based on mechanical temperature limits of the housing material used. Depending on the fluid pumped, the maximum safe operating temperature of the housing material can be reduced significantly.

A general aspect of lower temperatures is, that below 0°C (32°F) cold-brittling of the elastomers used within the pumps can results in accelerated wear. Regarding the housing materials, please note that PE - other than PP - keeps its mechanical strengths at low temperatures and PTFE keeps mechanically stable as well for an extended temperature range. ALMATEC pumps of the E-Series can therefore be operated safely as well within low-temperature installations: However, with liquids below 0°C (32°F) accelerated wear of internal parts has to be accepted. Moreover, freezing, bogging or crystallisation of the fluid pumped must be avoided, especially within the pump. Emptying the pump via the drainage system (optional equipment code R) may be a useful tool to assist this.

Please consider, that viscosity and specific gravity of most fluids change with temperature (most often increasing at lower temperature). Depending on the application, this fact may not only result in result in a reduced flow rate, the pump may even be unable to prime the thicker and/or “heavier” fluid any more.

Providing spare parts

We recommend having spare part kits “S” on stock. These include the relevant spare parts for your pump.

Only use original ALMATEC spare parts for repairs and / or preventive maintenance work. If this is not observed, the CE and ATEX markings, the declaration of conformity (s) and the guarantee claim for the pump will expire.

All work on the pump may only be carried out with the appropriate tools and by trained specialist personnel.

MAINTENANCE

Required tools

The general design of the ALMATEC C-Series is simple. We recommend to take the explosion view in hand to identify the parts by item number that is mentioned in the following. Each pump is delivered a metallic tool to (dis-)assemble the ball valve seats [5]. For the (dis-)assembly of the air valve [16], we recommend to use the special plastic mounting tool that comes with each spare part kits "S" (and on request). Further special tools are not required

	Tool list	Pump size	C 10	C 15	C 25	C 40	C 50	
Item	Description	Tool	Tool-size					
2	Valve stop, discharge valve	Face pin spanner wrench	5 mm	6 mm	8 mm	8mm	10mm	
5	Valve seat	ALMATEC Tool*	2 10 901 10	2 15 901 10	2 25 901 10	2 40 901 10	2 50 901 10	
7	Thread bolt	Slot screwdriver ***	0,8 x 5,0	0,8 x 5,0	1,0 x 5,5	1,6 x 8,0	1,6 x 8,0	
8	Plug, side housing	Face pin spanner wrench	5 mm	6 mm	8 mm	8mm	10mm	
16	PERSWING P® air control system, cpl	ALMATEC Tool** + ring wrench	1 08 901 54 19 mm	1 15 901 54 24 mm				
17	Air inlet	Open-end spanner	13 mm	19 mm		27mm		
19	Set screw, shaft	Allen key	-	5 mm	6 mm	8mm	10mm	
23	Housing bolt, cpl.	Open-end spanner/ ring wrench/socket wrench	8 mm	10 mm	13 mm		17mm	

* Supplied with each pump ** Supplied with each spare part kit *** Examples, please check yourself



Face pin spanner wrench



Disassembly

When dismantling a pump the mentioned procedures and safety notes on the pages 9-11 have to be considered generally. Among the different sizes of the C-Series - C 10 to C 25 - only the number of housing bolts [23] varies. Besides, for the sizes C 10 the shaft [18] additionally functions as the pilot piston for the air-valve. In C10-pumps, there are no shaft piston rings [20] nor set screws [19]. Please keep these differences in construction in mind when reading the following dismantling instructions.

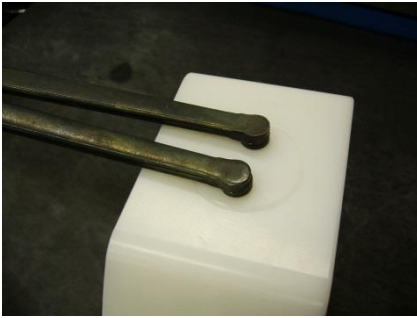

Figure. 13.1

Unscrew the housing bolts [23] on one side using two (socket) wrenches, remove tension disc [22] first and side housing [1] thereafter. Work carefully to ensure that the sealing surfaces in contact to the diaphragms are not damaged. Carefully draw the housing bolts [23] out of the pump and remove the second tension disc [22]. The centre housing [15]. Both side housings [1] and both manifolds [11/12] are removable now. Remove the manifold-O-rings [13] out of the side housings [1] for a possible renewal.

For further dismantling of the side housings [1], screw out the valve stop, discharge valve [2] with a face spin spanner wrench (figure 13.1). Alternatively, you can stick two housing bolts [23] into the holes in the valve stop [2] and loosen the valve stop with a third housing bolt [23] fixed in between the others. Take out the ball valve [4] and the O-ring, valve stop, discharge valve [3].



Figure. 13.2



Figure. 13.3

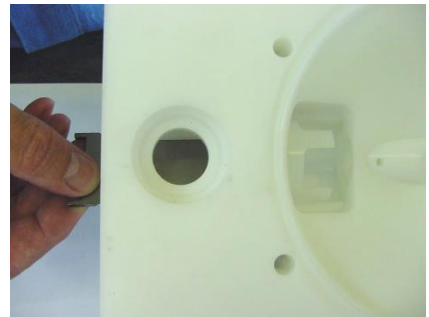

Figure. 13.4

Use the metallic mounting tool to unscrew the valve seat [5] (figure 13.2/13.3). The plug, side housing [8] can be unscrewed the same way as described for the valve stop [2]. Take care of O-ring plug side housing [9]. Loosen the thread bolt [7] with a slot screwdriver. Remove lock bolt [6] and afterwards valve ball [4]. Turn the mounting tool and screw the valve seat [5] into the side housing [1] (figure 13.4). The valve seat [5] can now be removed from inside the side housing.



Figure. 13.5

Screw one diaphragm [14] left-turning off the shaft [18] and pull the other diaphragm [14] together with the shaft [18] out of the center block [15]. Take out set screws shaft [19] of the diaphragms [14] by using an Allen key (figure 13.5). Remove both parts of the shaft piston rings [20] from their grooves carefully (figure 13.6); do not damage the edges in the center housing, a re-assembly of the same piston rings is impossible, they have to be replaced. Unscrew the muffler [21] and the air inlet [17] out of the center block [15]. To remove the *PERSWING P*® air control system [16], screw off both end caps – bets by using the ALMATEC plastic

mounting tool (figure 13.7). Take out main and pilot piston. Push out the air valve housing with the mounting tool turned around (figure 13.8).



Figure. 13.6



Figure. 13.7



Figure. 13.8

Assembly

The re-assembly of the components is principally carried out vice-versa to the dismantling. Here are some additional references.

For the installation of the *PERSWING P*® air control system [16], first screw in one end cap flushly into the center block [15]. Insert one of the six O-rings air-valve housing into the end cap from the inside. Moisture the four O-rings of the air-valve housing with a bit of water and push the housing into the center block [15] using the mounting tool. Take care that it slips in softly. Do never insert the housing violently with a hammer. In case the housing cocks or hardly gets in, take it out again completely and start again. Insert the main piston and the pilot piston. Lay the sixth O-ring on the edge of the air valve housing and screw in the second end cap.



Figure.14.1

To assemble new piston rings [20] (pump sizes C 15 -C 50 only), carefully shape them like kidneys with snap ring pliers and insert the rings into the grooves in the center block [15] (figure 14.1); completely press the rings into the grooves smoothly using some round tool.

Screw the set screws [19] into the diaphragms and tighten them. Fix the diaphragms [14] completely into the shaft [18] with the set screws [19]. Adjust the bores in the center block [15] to the diaphragm on both sides (turn slightly backwards if necessary). The sealing surfaces of the diaphragms and the side housings [1] have to be absolutely clean and undamaged; mere small scratches can cause leaking (if necessary,

smoothen the housing surfaces carefully with fine sandpaper).

Cautiously push the O-rings manifold [13] into the side housings [1] (avoid bending the rings by all means! If necessary, moisture and softly twist the rings). When installing the valve stop, discharge valve [2] always start with inserting the O-ring, valve stop discharge valve [3] into the side housing [1] carefully, do NOT shove the O-ring onto the valve stop [2]. It has to be ensured that the O-ring is in direct flat contact to the horizontal surface at the end of the thread (press in with an appropriate round stick if necessary). Afterwards insert lock bolt [6] and bolt together with the thread bolt [7]. Shove the shaft [18] on which one diaphragm [14] is mounted with set crew [19] into the center block [15], lay the side housing [1] and the tension disc [22] onto the diaphragm and fix its position with housing bolts [23]. After that, screw the other diaphragm [14] with set screw [19] onto the shaft [18] and carefully push the housing bolts [23] completely through the center block [15] [slightly turning the bolts helps them to find their way].

Adjust the second side housing [1] and the tension disc [22]. Fix the housing bolts [13] crosswise evenly according to the given torque values until the side housings [1] are situated on the center block [15]. Any further tightening of the bolts does not improve sealing but can deform the housing! Before putting the pump back into operation, the tightness of the pump has to be checked.

TROUBLE SHOOTING

Malfunction	Possible Reason	Solutions/Remarks
pump does not operate	air supply line blocked/closed muffler blocked working chambers blocked air control system defective discharge line blocked/closed	open air supply clean/replace muffler remove blockage replace air valve system clean/open line
pump operates unsteadily	piston rings worn air control system worn diaphragm rupture air control system soiled check valve blocked icing	replace piston rings replace air control system replace diaphragm, clean pump clean/replace air control system cleaning, removal of bulk particles improve air processing
air within liquid	suction line leaky container with liquid empty diaphragm rupture cavitation	seal suction line fill/new container replace diaphragm adapt suction lift, possibly install suction pressurized air chamber
insufficient discharge pressure	insufficient pressure/amount of driving air air supply line leaky air control system leaky check valve worn more air consuming components	increase air supply check/repair air supply replace air control system check/replace check valve increase pressure/amount of air
output decreases	air control system soiled icing air pressure drop suction line/inlet strainer soiled discharge line/outlet strainer soiled muffler blocked check valve worn change in viscosity more air consuming components	clean/replace air control system improve air processing: dryer/filter ensure sufficient supply of air cleaning cleaning replace the muffler replace valve change back/adjust pump increase pressure/amount of air
pump stops itself	icing of the air control system air pressure too low air pressure drop discharge line blocked air filter blocked valve closed air control system defective wear/leaking of air control system diaphragm rupture check valve blocked/worn	Improve air processing: dryer/heater etc. increase air pressure ensure sufficient air supply clean discharge line clean air filter open valve replace air control system replace air control system replace diaphragm, clean pump clean/replace check valve

Malfunction	Possible Reason	Solutions/Remarks
pumps operates, however suction capacity insufficient	<p>pump operates too fast</p> <p>operation beyond physical limits</p> <p>cavitation</p> <p>operation beyond pump capacity</p> <p>air cushion within suction/discharge line</p> <p>dry suction against discharge pressure</p> <p>valve filter within suction line closed</p> <p>valve filter within discharge line closed</p> <p>container with liquid empty</p> <p>vacuum inside the container</p> <p>wear of the check valves</p> <p>suction line leaky</p> <p>suction line blocked</p> <p>air pressure cushion at discharge</p> <p>check valve blocked</p>	<p>start more slowly</p> <p>adjust installation</p> <p>check, cool down</p> <p>adjust installation resp. install bigger pump</p> <p>bleed the line</p> <p>wet pump, start without pressure</p> <p>open valve/clean filter</p> <p>open valve/clean filter</p> <p>fill/new container</p> <p>bleed container</p> <p>replace valves</p> <p>seal suction line</p> <p>clean suction line</p> <p>bleed discharge line</p> <p>clean/replace valve</p>
insufficient suction capacity after pump repair	<p>connections tighten incompletely</p> <p>check valves inserted falsely</p>	<p>tighten/seal connections</p> <p>correct positioning of check valves</p>
diaphragm overstrained	<p>pressure within the plant/system</p> <p>inadmissible vacuum</p> <p>icing</p>	<p>ensure that pressure is only developed by the pump itself, check plant/valves,</p> <p>replace diaphragms</p> <p>check suction line, open valve</p> <p>improve air processing</p>
leaking between housing parts	<p>housing bolts loosened</p> <p>O-rings sleeve damaged</p> <p>diaphragms attacked chemically</p> <p>diaphragms overstrained</p> <p>tension installation/pipework</p>	<p>tighten bolts, check pump</p> <p>replace O-rings</p> <p>replace diaphragms</p> <p>replace diaphragms</p> <p>loosen, eliminate tension, use of a compensator</p>
muffler grey	driving air too humid, icing	improve quality of driving air
muffler black	soiled, oily air	improve quality of driving air, install sensitive filter in suction line
pump is connected to air but does not operate	<p>air control system blocked</p> <p>bulk particles/dirt</p> <p>chemical influence (O-rings swollen)</p> <p>valve closed in discharge line</p>	<p>clean/replace air control system</p> <p>clean pump, replace necessary parts, improve air quality</p> <p>check, replace damaged parts</p> <p>open valve</p>
liquid leaves the pump via the muffler	diaphragm rupture	replace diaphragms, clean pump

SPARE PART LISTS
Pump Code C 10 EEE – UVT

Pump Size				C 10	C 10-1	C 10-2
Item	Pc.	Description	Material	Part number	Part number	Part number
1	2	Side housing, code E	PE	17 10 010 51	17 10 010 51	17 10 010 51
		Side housing, code F	PE conductive	17 10 010 55	17 10 010 55	17 10 010 55
		Side housing, code T	PTFE	17 10 010 60	17 10 010 60	17 10 010 60
		Side housing, code U	PTFE conductive	17 10 010 65	17 10 010 65	17 10 010 65
2	2	Valve stop discharge valve, code E	PE	7 10 015 51	7 10 015 51	7 10 015 51
		Valve stop discharge valve, code F	PE conductive	7 10 015 56	7 10 015 56	7 10 015 56
		Valve stop discharge valve, code T	PTFE	7 10 015 60	7 10 015 60	7 10 015 60
		Valve stop discharge valve, code U	PTFE conductive	7 10 015 65	7 10 015 65	7 10 015 65
3	2	O-ring, valve stop discharge valve, code E	EPDM	9 19 624 72	9 19 624 72	9 19 624 72
		O-ring, valve stop discharge valve, code V	FKM	9 19 624 75	9 19 624 75	9 19 624 75
4	4	Ball valve, code E	EPDM	4 15 032 72	4 15 032 72	4 15 032 72
		Ball valve, code T	PTFE	4 15 032 60	4 15 032 60	4 15 032 60
5	4	Valve seat for ball valve, code E and F	PE	2 10 018 52	2 10 018 52	2 10 018 52
		Valve seat for ball valve, code T and U	PTFE	2 10 018 60	2 10 018 60	2 10 018 60
6	2	Lock bolt, code E and F	PE	7 10 013 52	7 10 013 52	7 10 013 52
		Lock bolt, code T and U	PTFE	7 10 013 60	7 10 013 60	7 10 013 60
7	4	Bolt valve stop, code E and F	PE	7 08 014 52	7 08 014 52	7 08 014 52
		Bolt valve stop, code T and U	PTFE	7 08 014 60	7 08 014 60	7 08 014 60
8	2	Plug side housing, code E	PE	7 10 017 51	7 10 017 51	7 10 017 51
		Plug side housing, code F	PE conductive	7 10 017 55	7 10 017 55	7 10 017 55
		Plug side housing, code T	PTFE	7 10 017 60	7 10 017 60	7 10 017 60
		Plug side housing, code U	PTFE conductive	7 10 017 65	7 10 017 65	7 10 017 65
9	2	O-ring, plug side housing, code E	EPDM	9 20 602 72	9 20 602 72	9 20 602 72
		O-ring, plug side housing, code V	FKM	9 20 602 75	9 20 602 75	9 20 602 75
10	4	<i>Shock absorbers</i>	<i>NR</i>	<i>1 08 322 85</i>	<i>17 10 322 85</i>	<i>17 10 422 85</i>
11	1	Manifold discharge side, code E	PE	17 10 011 51	17 10 011 51	17 10 011 51
		Manifold discharge side, code F	PE conductive	17 10 011 55	17 10 011 55	17 10 011 55
		Manifold discharge side, code T	PTFE	17 10 011 60	17 10 011 60	17 10 011 60
		Manifold discharge side, code U	PTFE conductive	17 10 011 65	17 10 011 65	17 10 011 65
12	1	Manifold suction side, code E	PE	17 10 011 51	17 10 012 51	17 10 012 51
		Manifold suction side, code F	PE conductive	17 10 011 55	17 10 012 55	17 10 012 55
		Manifold suction side, code T	PTFE	17 10 011 60	17 10 012 60	17 10 012 60
		Manifold suction side, code U	PTFE conductive	17 10 011 65	17 10 012 65	17 10 012 65
13	4	O-ring, manifold, code E	EPDM	9 15 630 72	9 15 630 72	9 15 630 72
		O-ring, manifold, code V	FKM	9 15 630 75	9 15 630 75	9 15 630 75
14	2	Diaphragm, code E	EPDM	1 10 031 72	1 10 031 72	1 10 031 72
		Diaphragm, code V	PTFE/EPDM	1 10 031 67	1 10 031 67	1 10 031 67
15	1	<i>Center block, code E and T</i>	<i>PE</i>	<i>17 10 040 51</i>	<i>17 10 040 51</i>	<i>17 10 040 51</i>
		<i>Center block, code F and U</i>	<i>PE conductive</i>	<i>17 10 040 55</i>	<i>17 10 040 55</i>	<i>17 10 040 55</i>
16	1	<i>Perswing P® air control system, cpl.</i>	<i>PETP</i>	<i>2 08 001 84</i>	<i>2 08 001 84</i>	<i>2 08 001 84</i>
17	1	<i>Air inlet</i>	<i>PETP</i>	<i>1 08 047 84</i>	<i>1 08 047 84</i>	<i>1 08 047 84</i>
18	1	<i>Shaft</i>	<i>1.4301</i>	-	-	-
19	2	<i>Set screw shaft</i>	<i>1.4305</i>	-	-	-
20	2	<i>Shaft piston ring, cpl.</i>	<i>PTFE</i>	-	-	-
21	1	<i>Muffler, cpl.</i>	<i>PE</i>	<i>1 08 244 51</i>	<i>1 08 244 51</i>	<i>1 08 244 51</i>
22	2	<i>Tension disc</i>	<i>1.4301</i>	<i>7 10 008 22</i>	<i>7 10 008 22</i>	<i>7 10 008 22</i>
23	4	<i>Housing bolt, cpl.</i>	<i>1.4305</i>	<i>17 10 020 22</i>	<i>17 10 020 22</i>	<i>17 10 020 22</i>

All parts in italics are **not** product wetted.

Please see page 4 for explanation of the pump code.

When ordering please state the serial number of the pump.

For spare part lists for special equipment please see page 21 and the following ones.

Pump Code C 15 EEE – UVT

Pump Size				C 15	C 15-1	C 15-2
Item	Pc.	Description	Material	Part number	Part number	Part number
1	2	Side housing, code E	PE	17 15 010 51	17 15 010 51	17 15 010 51
		Side housing, code F	PE conductive	17 15 010 55	17 15 010 55	17 15 010 55
		Side housing, code T	PTFE	17 15 010 60	17 15 010 60	17 15 010 60
		Side housing, code U	PTFE conductive	17 15 010 65	17 15 010 65	17 15 010 65
2	2	Valve stop discharge valve, code E	PE	7 15 015 51	7 15 015 51	7 15 015 51
		Valve stop discharge valve, code F	PE conductive	7 15 015 56	7 15 015 56	7 15 015 56
		Valve stop discharge valve, code T	PTFE	7 15 015 60	7 15 015 60	7 15 015 60
		Valve stop discharge valve, code U	PTFE conductive	7 15 015 65	7 15 015 65	7 15 015 65
3	2	O-ring, valve stop discharge valve, code E	EPDM	9 24 625 72	9 24 625 72	9 24 625 72
		O-ring, valve stop discharge valve, code V	FKM	9 24 625 75	9 24 625 75	9 24 625 75
4	4	Ball valve, code E	EPDM	1 15 032 72	1 15 032 72	1 15 032 72
		Ball valve, code T	PTFE	1 15 032 60	1 15 032 60	1 15 032 60
5	4	Valve seat for ball valve, code E and F	PE	2 15 018 52	2 15 018 52	2 15 018 52
		Valve seat for ball valve, code T and U	PTFE	2 15 018 60	2 15 018 60	2 15 018 60
6	2	Lock bolt, code E and F	PE	7 15 013 52	7 15 013 52	7 15 013 52
		Lock bolt, code T and U	PTFE	7 15 013 60	7 15 013 60	7 15 013 60
7	4	Bolt valve stop, code E and F	PE	2 08 014 52	2 08 014 52	2 08 014 52
		Bolt valve stop, code T and U	PTFE	2 08 014 60	2 08 014 60	2 08 014 60
8	2	Plug side housing, code E	PE	7 15 017 51	7 15 017 51	7 15 017 51
		Plug side housing, code F	PE conductive	7 15 017 55	7 15 017 55	7 15 017 55
		Plug side housing, code T	PTFE	7 15 017 60	7 15 017 60	7 15 017 60
		Plug side housing, code U	PTFE conductive	7 15 017 65	7 15 017 65	7 15 017 65
9	2	O-ring, plug side housing, code E	EPDM	9 25 610 72	9 25 610 72	9 25 610 72
		O-ring, plug side housing, code V	FKM	9 25 610 75	9 25 610 75	9 25 610 75
10	4	Shock absorbers	NR	1 15 322 85	1 15 322 85	1 15 322 85
11	1	Manifold discharge side, code E	PE	17 15 011 51	17 15 011 51	17 15 111 51
		Manifold discharge side, code F	PE conductive	17 15 011 55	17 15 011 55	17 15 111 55
		Manifold discharge side, code T	PTFE	17 15 011 60	17 15 011 60	17 15 111 60
		Manifold discharge side, code U	PTFE conductive	17 15 011 65	17 15 011 65	17 15 111 65
12	1	Manifold suction side, code E	PE	17 15 112 51	17 15 012 51	17 15 112 51
		Manifold suction side, code F	PE conductive	17 15 112 55	17 15 012 55	17 15 112 55
		Manifold suction side, code T	PTFE	17 15 112 60	17 15 012 60	17 15 112 60
		Manifold suction side, code U	PTFE conductive	17 15 112 65	17 15 012 65	17 15 112 65
13	4	O-ring, manifold, code E	EPDM	9 20 631 72	9 20 631 72	9 20 631 72
		O-ring, manifold, code V	FKM	9 20 631 75	9 20 631 75	9 20 631 75
14	2	Diaphragm, code E	EPDM	1 15 031 72	1 15 031 72	1 15 031 72
		Diaphragm, code V	PTFE/EPDM	1 15 031 67	1 15 031 67	1 15 031 67
15	1	Center block, code E and T	PE	25 15 040 51	25 15 040 51	25 15 040 51
		Center block, code F and U	PE conductive	25 15 040 55	25 15 040 55	25 15 040 55
16	1	Perswing P® air control system, cpl.	PETP	2 15 001 84	2 15 001 84	2 15 001 84
17	1	Air inlet	PETP	1 15 047 84	1 15 047 84	1 15 047 84
18	1	Shaft	1.4301	2 15 030 22	2 15 030 22	2 15 030 22
19	2	Set screw shaft	1.4305	9 10 220 22	9 10 220 22	9 10 220 22
20	2	Shaft piston ring, cpl.	PTFE	1 15 041 64	1 15 041 64	1 15 041 64
21	1	Muffler, cpl.	PE	1 15 244 51	1 15 244 51	1 15 244 51
22	2	Tension disc	1.4301	7 15 008 22	7 15 008 22	7 15 008 22
23	4	Housing bolt, cpl.	1.4305	17 15 020 22	17 15 020 22	17 15 020 22

All parts in italics are **not** product wetted.

Please see page 4 for explanation of the pump code.

When ordering please state the serial number of the pump.

For spare part lists for special equipment please see page 21 and the following ones.

Pump Code C 25 EEE – UVT

Pump Size				C 25	C 25-1	C 25-2
Item	Pc.	Description	Material	Part number	Part number	Part number
1	2	Side housing, code E	PE	17 25 010 51	17 25 010 51	17 25 010 51
		Side housing, code F	PE conductive	17 25 010 55	17 25 010 55	17 25 010 55
		Side housing, code T	PTFE	17 25 010 60	17 25 010 60	17 25 010 60
		Side housing, code U	PTFE conductive	17 25 010 65	17 25 010 65	17 25 010 65
2	2	Valve stop discharge valve, code E	PE	7 25 015 51	7 25 015 51	7 25 015 51
		Valve stop discharge valve, code F	PE conductive	7 25 015 56	7 25 015 56	7 25 015 56
		Valve stop discharge valve, code T	PTFE	7 25 015 60	7 25 015 60	7 25 015 60
		Valve stop discharge valve, code U	PTFE conductive	7 25 015 65	7 25 015 65	7 25 015 65
3	2	O-ring, valve stop discharge valve, code E	EPDM	9 38 626 72	9 38 626 72	9 38 626 72
		O-ring, valve stop discharge valve, code V	FKM	9 38 626 75	9 38 626 75	9 38 626 75
4	4	Ball valve, code E	EPDM	1 25 032 72	1 25 032 72	1 25 032 72
		Ball valve, code T	PTFE	1 25 032 60	1 25 032 60	1 25 032 60
5	4	Valve seat for ball valve, code E and F	PE	2 25 018 52	2 25 018 52	2 25 018 52
		Valve seat for ball valve, code T and U	PTFE	2 25 018 60	2 25 018 60	2 25 018 60
6	2	Lock bolt, code E and F	PE	7 25 013 52	7 25 013 52	7 25 013 52
		Lock bolt, code T and U	PTFE	7 25 013 60	7 25 013 60	7 25 013 60
7	4	Bolt valve stop, code E and F	PE	2 10 014 52	2 10 014 52	2 10 014 52
		Bolt valve stop, code T and U	PTFE	2 10 014 60	2 10 014 60	2 10 014 60
8	2	Plug side housing, code E	PE	7 25 017 51	7 25 017 51	7 25 017 51
		Plug side housing, code F	PE conductive	7 25 017 55	7 25 017 55	7 25 017 55
		Plug side housing, code T	PTFE	7 25 017 60	7 25 017 60	7 25 017 60
		Plug side housing, code U	PTFE conductive	7 25 017 65	7 25 017 65	7 25 017 65
9	2	O-ring, plug side housing, code E	EPDM	9 40 613 72	9 40 613 72	9 40 613 72
		O-ring, plug side housing, code V	FKM	9 40 613 75	9 40 613 75	9 40 613 75
10	4	<i>Shock absorbers</i>	<i>NR</i>	<i>1 15 322 85</i>	<i>1 15 322 85</i>	<i>17 15 322 85</i>
11	1	Manifold discharge side, code E	PE	17 25 011 51	17 25 011 51	17 25 011 51
		Manifold discharge side, code F	PE conductive	17 25 011 55	17 25 011 55	17 25 011 55
		Manifold discharge side, code T	PTFE	17 25 011 60	17 25 011 60	17 25 011 60
		Manifold discharge side, code U	PTFE conductive	17 25 011 65	17 25 011 65	17 25 011 65
12	1	Manifold suction side, code E	PE	17 25 212 51	17 25 012 51	17 25 012 51
		Manifold suction side, code F	PE conductive	17 25 212 55	17 25 012 55	17 25 012 55
		Manifold suction side, code T	PTFE	17 25 212 60	17 25 012 60	17 25 012 60
		Manifold suction side, code U	PTFE conductive	17 25 212 65	17 25 012 65	17 25 012 65
13	4	O-ring, manifold, code E	EPDM	9 33 632 72	9 33 632 72	9 33 632 72
		O-ring, manifold, code V	FKM	9 33 632 75	9 33 632 75	9 33 632 75
14	2	Diaphragm, code E	EPDM	1 25 031 72	1 25 031 72	1 25 031 72
		Diaphragm, code V	PTFE/EPDM	1 25 031 67	1 25 031 67	1 25 031 67
15	1	<i>Center block, code E and T</i>	<i>PE</i>	<i>25 25 040 51</i>	<i>25 25 040 51</i>	<i>25 25 040 51</i>
		<i>Center block, code F and U</i>	<i>PE conductive</i>	<i>25 25 040 55</i>	<i>25 25 040 55</i>	<i>25 25 040 55</i>
16	1	<i>Perswing P® air control system, cpl.</i>	<i>PETP</i>	<i>2 15 001 84</i>	<i>2 15 001 84</i>	<i>2 15 001 84</i>
17	1	<i>Air inlet</i>	<i>PETP</i>	<i>1 15 047 84</i>	<i>1 15 047 84</i>	<i>1 15 047 84</i>
18	1	<i>Shaft</i>	<i>1.4301</i>	<i>2 25 030 22</i>	<i>2 25 030 22</i>	<i>2 25 030 22</i>
19	2	<i>Set screw shaft</i>	<i>1.4305</i>	<i>9 12 221 22</i>	<i>9 12 221 22</i>	<i>9 12 221 22</i>
20	2	<i>Shaft piston ring, cpl.</i>	<i>PTFE</i>	<i>1 25 041 64</i>	<i>1 25 041 64</i>	<i>1 25 041 64</i>
21	1	<i>Muffler, cpl.</i>	<i>PE</i>	<i>1 15 244 51</i>	<i>1 15 244 51</i>	<i>1 15 244 51</i>
22	2	<i>Tension disc</i>	<i>1.4301</i>	<i>7 25 008 22</i>	<i>7 25 008 22</i>	<i>7 25 008 22</i>
23	4	<i>Housing bolt, cpl.</i>	<i>1.4305</i>	<i>17 25 020 22</i>	<i>17 25 020 22</i>	<i>17 25 020 22</i>

All parts in italics are **not** product wetted.

Please see page 4 for explanation of the pump code.

When ordering please state the serial number of the pump.

For spare part lists for special equipment please see page 21 and the following ones.

Pump Code C 40 EEE – UVT

Pump Size				C 40	C 40-1	C 40-2
Item	Pc.	Description	Material	Part number	Part number	Part number
1	2	Side housing, code E	PE	17 40 010 51	17 40 010 51	17 40 010 51
		Side housing, code F	PE conductive	17 40 010 55	17 40 010 55	17 40 010 55
		Side housing, code T	PTFE	17 40 010 60	17 40 010 60	17 40 010 60
		Side housing, code U	PTFE conductive	17 40 010 65	17 40 010 65	17 40 010 65
2	2	Valve stop discharge valve, code E	PE	7 40 015 51	7 40 015 51	7 40 015 51
		Valve stop discharge valve, code F	PE conductive	7 40 015 56	7 40 015 56	7 40 015 56
		Valve stop discharge valve, code T	PTFE	7 40 015 60	7 40 015 60	7 40 015 60
		Valve stop discharge valve, code U	PTFE conductive	7 40 015 65	7 40 015 65	7 40 015 65
3	2	O-ring, valve stop discharge valve, code E	EPDM	9 57 627 72	9 57 627 72	9 57 627 72
		O-ring, valve stop discharge valve, code V	FKM	9 57 627 75	9 57 627 75	9 57 627 75
4	4	Ball valve, code E	EPDM	1 40 032 72	1 40 032 72	1 40 032 72
		Ball valve, code T	PTFE	1 40 032 60	1 40 032 60	1 40 032 60
5	4	Valve seat for ball valve, code E and F	PE	2 40 018 52	2 40 018 52	2 40 018 52
		Valve seat for ball valve, code T and U	PTFE	2 40 018 60	2 40 018 60	2 40 018 60
6	2	Lock bolt, code E and F	PE	7 40 013 52	7 40 013 52	7 40 013 52
		Lock bolt, code T and U	PTFE	7 40 013 60	7 40 013 60	7 40 013 60
7	4	Bolt valve stop, code E and F	PE	2 15 014 52	2 15 014 52	2 15 014 52
		Bolt valve stop, code T and U	PTFE	2 15 014 60	2 15 014 60	2 15 014 60
8	2	Plug side housing, code E	PE	7 40 017 51	7 40 017 51	7 40 017 51
		Plug side housing, code F	PE conductive	7 40 017 55	7 40 017 55	7 40 017 55
		Plug side housing, code T	PTFE	7 40 017 60	7 40 017 60	7 40 017 60
		Plug side housing, code U	PTFE conductive	7 40 017 65	7 40 017 65	7 40 017 65
9	2	O-ring, plug side housing, code E	EPDM	9 62 634 72	9 62 634 72	9 62 634 72
		O-ring, plug side housing, code V	FKM	9 62 634 75	9 62 634 75	9 62 634 75
10	4	<i>Shock absorbers</i>	<i>NR</i>	<i>1 40 322 85</i>	<i>17 40 322 85</i>	<i>17 40 322 85</i>
11	1	Manifold discharge side, code E	PE	17 40 011 51	17 40 011 51	17 40 111 51
		Manifold discharge side, code F	PE conductive	17 40 011 55	17 40 011 55	17 40 111 55
		Manifold discharge side, code T	PTFE	17 40 011 60	17 40 011 60	17 40 111 60
		Manifold discharge side, code U	PTFE conductive	17 40 011 65	17 40 011 65	17 40 111 65
12	1	Manifold suction side, code E	PE	17 40 112 51	17 40 012 51	17 40 112 51
		Manifold suction side, code F	PE conductive	17 40 112 55	17 40 012 55	17 40 112 55
		Manifold suction side, code T	PTFE	17 40 112 60	17 40 012 60	17 40 112 60
		Manifold suction side, code U	PTFE conductive	17 40 112 65	17 40 012 65	17 40 112 65
13	4	O-ring, manifold, code E	EPDM	9 50 633 72	9 50 633 72	9 50 633 72
		O-ring, manifold, code V	FKM	9 50 633 75	9 50 633 75	9 50 633 75
14	2	Diaphragm, code E	EPDM	1 40 031 72	1 40 031 72	1 40 031 72
		Diaphragm, code V	PTFE/EPDM	1 40 031 67	1 40 031 67	1 40 031 67
15	1	<i>Center block, code E and T</i>	<i>PE</i>	<i>25 40 040 51</i>	<i>25 40 040 51</i>	<i>25 40 040 51</i>
		<i>Center block, code F and U</i>	<i>PE conductive</i>	<i>25 40 040 55</i>	<i>25 40 040 55</i>	<i>25 40 040 55</i>
16	1	<i>Perswing P® air control system, cpl.</i>	<i>PETP</i>	<i>2 40 001 84</i>	<i>2 40 001 84</i>	<i>2 40 001 84</i>
17	1	<i>Air inlet</i>	<i>PETP</i>	<i>1 40 047 84</i>	<i>1 40 047 84</i>	<i>1 40 047 84</i>
18	1	<i>Shaft</i>	<i>1.4301</i>	<i>2 40 030 22</i>	<i>2 40 030 22</i>	<i>2 40 030 22</i>
19	2	<i>Set screw shaft</i>	<i>1.4305</i>	<i>9 16 222 22</i>	<i>9 16 222 22</i>	<i>9 16 222 22</i>
20	2	<i>Shaft piston ring, cpl.</i>	<i>PTFE</i>	<i>1 40 041 64</i>	<i>1 40 041 64</i>	<i>1 40 041 64</i>
21	1	<i>Muffler, cpl.</i>	<i>PE</i>	<i>1 40 244 51</i>	<i>1 40 244 51</i>	<i>1 40 244 51</i>
22	2	<i>Tension disc</i>	<i>1.4301</i>	<i>7 40 008 22</i>	<i>7 40 008 22</i>	<i>7 40 008 22</i>
23	4	<i>Housing bolt, cpl.</i>	<i>1.4305</i>	<i>17 40 020 22</i>	<i>17 40 020 22</i>	<i>17 40 020 22</i>

All parts in italics are **not** product wetted.

Please see page 4 for explanation of the pump code.

When ordering please state the serial number of the pump.

For spare part lists for special equipment please see page 21 and the following ones.

Pump Code C 50 EEE – UVT

Pump Size				C 50	C 50-1	C 50-2
Item	Pc.	Description	Material	Part number	Part number	Part number
1	2	Side housing, code E	PE	17 50 010 51	17 50 010 51	17 50 010 51
		Side housing, code F	PE conductive	17 50 010 55	17 50 010 55	17 50 010 55
		Side housing, code T	PTFE	17 50 010 60	17 50 010 60	17 50 010 60
		Side housing, code U	PTFE conductive	17 50 010 65	17 50 010 65	17 50 010 65
2	2	Valve stop discharge valve, code E	PE	7 50 015 51	7 50 015 51	7 50 015 51
		Valve stop discharge valve, code F	PE conductive	7 50 015 56	7 50 015 56	7 50 015 56
		Valve stop discharge valve, code T	PTFE	7 50 015 60	7 50 015 60	7 50 015 60
		Valve stop discharge valve, code U	PTFE conductive	7 50 015 65	7 50 015 65	7 50 015 65
3	2	O-ring, valve stop discharge valve, code E	EPDM	9 76 628 72	9 76 628 72	9 76 628 72
		O-ring, valve stop discharge valve, code V	FKM	9 76 628 75	9 76 628 75	9 76 628 75
4	4	Ball valve, code E	EPDM	1 50 032 72	1 50 032 72	1 50 032 72
		Ball valve, code T	PTFE	1 50 032 60	1 50 032 60	1 50 032 60
5	4	Valve seat for ball valve, code E and F	PE	2 50 018 52	2 50 018 52	2 50 018 52
		Valve seat for ball valve, code T and U	PTFE	2 50 018 60	2 50 018 60	2 50 018 60
6	2	Lock bolt, code E and F	PE	7 50 013 52	7 50 013 52	7 50 013 52
		Lock bolt, code T and U	PTFE	7 50 013 60	7 50 013 60	7 50 013 60
7	4	Bolt valve stop, code E and F	PE	2 15 014 52	2 15 014 52	2 15 014 52
		Bolt valve stop, code T and U	PTFE	2 15 014 60	2 15 014 60	2 15 014 60
8	2	Plug side housing, code E	PE	7 50 017 51	7 50 017 51	7 50 017 51
		Plug side housing, code F	PE conductive	7 50 017 55	7 50 017 55	7 50 017 55
		Plug side housing, code T	PTFE	7 50 017 60	7 50 017 60	7 50 017 60
		Plug side housing, code U	PTFE conductive	7 50 017 65	7 50 017 65	7 50 017 65
9	2	O-ring, plug side housing, code E	EPDM	9 79 353 72	9 79 353 72	9 79 353 72
		O-ring, plug side housing, code V	FKM	9 79 353 75	9 79 353 75	9 79 353 75
10	4	<i>Shock absorbers</i>	<i>NR</i>	<i>1 40 322 85</i>	<i>17 40 322 85</i>	<i>17 40 322 85</i>
11	1	Manifold discharge side, code E	PE	17 50 111 51	17 50 011 51	17 50 111 51
		Manifold discharge side, code F	PE conductive	17 50 111 55	17 50 011 55	17 50 111 55
		Manifold discharge side, code T	PTFE	17 50 111 60	17 50 011 60	17 50 111 60
		Manifold discharge side, code U	PTFE conductive	17 50 111 65	17 50 011 65	17 50 111 65
12	1	Manifold suction side, code E	PE	17 50 012 51	17 50 012 51	17 50 112 51
		Manifold suction side, code F	PE conductive	17 50 012 55	17 50 012 55	17 50 112 55
		Manifold suction side, code T	PTFE	17 50 012 60	17 50 012 60	17 50 112 60
		Manifold suction side, code U	PTFE conductive	17 50 012 65	17 50 012 65	17 50 112 65
13	4	O-ring, manifold, code E	EPDM	9 62 634 72	9 62 634 72	9 62 634 72
		O-ring, manifold, code V	FKM	9 62 634 75	9 62 634 75	9 62 634 75
14	2	Diaphragm, code E	EPDM	1 50 031 72	1 50 031 72	1 50 031 72
		Diaphragm, code V	PTFE/EPDM	1 50 031 67	1 50 031 67	1 50 031 67
15	1	<i>Center block, code E and T</i>	<i>PE</i>	<i>17 50 040 51</i>	<i>17 50 040 51</i>	<i>17 50 040 51</i>
		<i>Center block, code F and U</i>	<i>PE conductive</i>	<i>17 50 040 55</i>	<i>17 50 040 55</i>	<i>17 50 040 55</i>
16	1	<i>Perswing P® air control system, cpl.</i>	<i>PETP</i>	<i>2 50 201 84</i>	<i>2 50 201 84</i>	<i>2 50 201 84</i>
17	1	<i>Air inlet</i>	<i>PETP</i>	<i>1 40 047 84</i>	<i>1 40 047 84</i>	<i>1 40 047 84</i>
18	1	<i>Shaft</i>	<i>1.4301</i>	<i>2 50 030 22</i>	<i>2 50 030 22</i>	<i>2 50 030 22</i>
19	2	<i>Set screw shaft</i>	<i>1.4305</i>	<i>9 20 223 22</i>	<i>9 20 223 22</i>	<i>9 20 223 22</i>
20	2	<i>Shaft piston ring, cpl.</i>	<i>PTFE</i>	<i>1 50 041 64</i>	<i>1 50 041 64</i>	<i>1 50 041 64</i>
21	1	<i>Muffler, cpl.</i>	<i>PE</i>	<i>1 50 244 51</i>	<i>1 50 244 51</i>	<i>1 50 244 51</i>
22	2	<i>Tension disc</i>	<i>1.4301</i>	<i>7 50 008 22</i>	<i>7 50 008 22</i>	<i>7 50 008 22</i>
23	4	<i>Housing bolt, cpl.</i>	<i>1.4305</i>	<i>17 50 020 22</i>	<i>17 50 020 22</i>	<i>17 50 020 22</i>

All parts in italics are **not** product wetted.

Please see page 4 for explanation of the pump code.

When ordering please state the serial number of the pump.

For spare part lists for special equipment please see page 21 and the following ones.

EXPLODED VIEW

C-Series

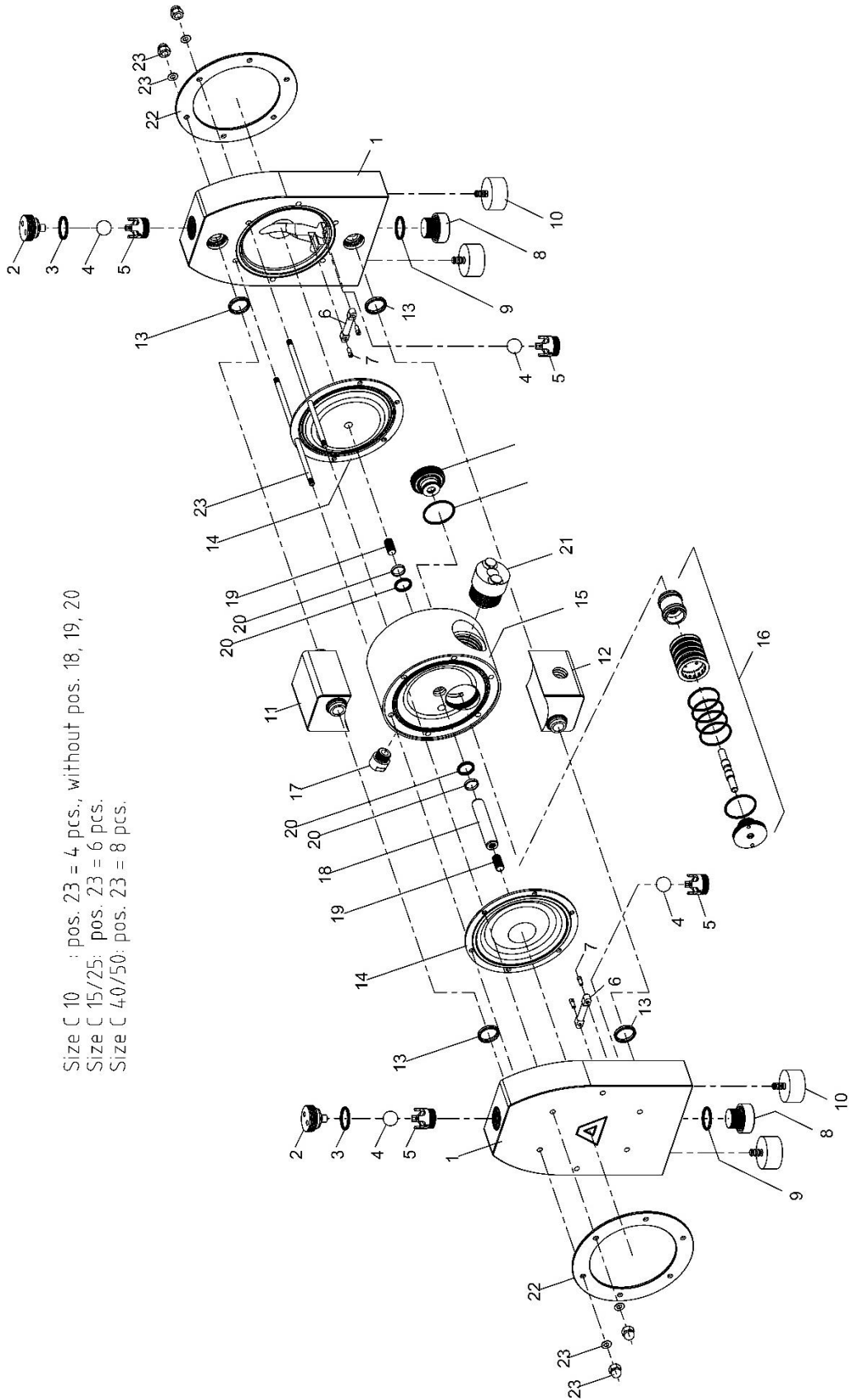

Size C 10 : pos. 23 = 4 pcs., without pos. 18, 19, 20

Size C 15/25: pos. 23 = 6 pcs.

Size C 40/50: pos. 23 = 8 pcs.

OPTIONAL EQUIPMENT

For special requirements ALMATEC air-operated double diaphragm pumps of the C-Series can be furnished with several optional equipment. The pump code informs which of these are included in the pump. The code is noted on the identification plate on the pump. In the spare part lists all non-wetted parts are in italics.

Stroke counting (option code C 2, C 3, C 4, C 9, C 10)

Code C 2 / C 3 / C 4 – Capacitive stroke counting

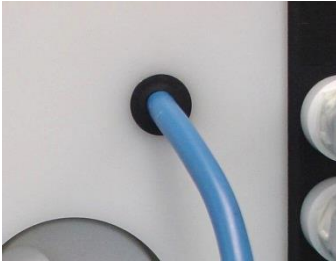

A sensor [50] is installed in the center block [15] to count the strokes. The diaphragm movement is scanned without contact by this sensor: a safe form of monitoring totally independent of external influences and the pump's mode of operation. The issued sensor pulses can be output to existing detectors or to a stroke counter (can also be supplied). When the preset value is reached, the stroke counter outputs a signal which can then be processed further, for instance in order to shut down the pump via a solenoid valve.

The stroke counting system is available in three variations:

- C 2 Stroke sensor (Namur), also for explosion-proof zone
- C 3 Stroke counting system complete with sensor and stroke counter
- C 4 Stroke counting system complete with sensor, stroke counter and controller for explosion-proof zone

In case only the sensor is included (code C 2), it has to be connected to an existing controller with Namur inlet. For applications an explosion-proof device is required for (code C 4) the intrinsically safe controller has to be installed between the sensor and the counter. The wiring diagram and technical data can be found on the electric units themselves. For further details, please refer to the data delivered by the manufacturers of the components. The controllers have to be installed in a suitable cabinet.

Code C 9 / C 10 – Pneumatic stroke counting

Differently from the optional equipment codes C 2 - C 4, the strokes of the pump are registered pneumatically on the codes C 9 / C 10. The pressure sensor registers the changes in pressure within the air chamber behind one of the diaphragms and it converts the pneumatic impulse into an electrical signal.

- C 9 consisting of:
 - Pressure sensor incl. 2,5 m cable and plug for pressure sensor
 - 2,5 m connection hose DN 4/6 with screwed connectors (pump side & sensors side) for hose 4/6
 - Mounting bracket with screws
- C 10 consisting of:
 - As C 9 however including stroke counter

For assembly screw the adaptor elbow (or adaptor straight for pump sizes E 08 / E 10) into the additional air connection of the pump (it is possible that the adaptor is already installed). The position of the air inlet varies depending on the pump type and the pump size (see comments below). Link up the adaptor and the pressure switch with the hose. Connect the socket to the electrical connection plug of the pressure switch and the cable to existing registering devices (code C 9) resp. to the enclosed stroke counter (code C 10). Technical data, connection schemes and further details can be found in the technical documentation delivered by the manufacturers of the pressure switch and the stroke counter.



The pneumatic stroke counting system requires a minimum air pressure of 1.5 bar for optimal function!

The air inlet for the pneumatic stroke counting system must not be confused with the actual pump air inlet.

Spare part list stroke counting					C 10	C 15	C 25	C40	C50
Code	Pos	Qty.	Description	Material	Part-No.	Part-No.	Part-No.	Part-No.	Part-No.
C2	4	1	Center block for Sensor: - Code E.. and T.. - Code F.. and U..	PE PE-conduct.	- -	25 15 240 51 25 15 240 55	25 25 240 51 25 25 240 55	25 40 240 51 25 40 240 55	17 50 240 51 17 50 240 55
	50 -	1 1	Stroke sensor, Namur O-ring, stroke sensor	diverse NBR	- -	1 00 072 99 9 25 535 71	1 00 072 99 9 25 535 71	1 00 072 99 9 25 535 71	1 00 072 99 9 25 535 71
C3	-	1	as C 2, but additional: Clamp amplifier	diverse	-	1 00 171 99	1 00 171 99	1 00 171 99	1 00 171 99
	-	1	Stroke counter	diverse	-	10007199-01	10007199-01	10007199-01	10007199-01
C4	-	1	as C 2, but additional: Controller	diverse	-	1 00 370 99	1 00 370 99	1 00 370 99	1 00 370 99
	-	1	Stroke counter	diverse	-	10007199-01	10007199-01	10007199-01	10007199-01
C9	4*	1	Center block with additional air inlet R ¼:	PE PE-conduct.	- -	25 15 140 51 25 15 140 55	25 25 140 51 25 25 140 55	25 40 140 51 25 40 140 55	17 50 140 51 17 50 140 55
	-	1	Adapter elbow (C 10 with straight adapter)	PP	1 00 877 51	1 00 875 51	1 00 875 51	1 00 875 51	1 00 875 51
	-	1	Hose	PE	1 00 876 51	1 00 876 51	1 00 876 51	1 00 876 51	1 00 876 51
	-	1	Pressure swith, cpl.	diverse	1 00 972 99	1 00 972 99	1 00 972 99	1 00 972 99	1 00 972 99
	-	1	Socket with cable	diverse	1 00 973 99	1 00 973 99	1 00 973 99	1 00 973 99	1 00 973 99
C10	-	1	as C 9, but additional: Stroke counter	diverse	10007199-01	10007199-01	10007199-01	10007199-01	10007199-01

All parts are non-wetted

Diaphragm monitoring (Extra equipment code D 1, D 3)



Although ALMATEC diaphragms with integrated metal core are designed for an optimum service life, the diaphragm remains a wear part. If it breaks, liquid can leak into the center housing and possibly emerge through the muffler. This can be prevented simply and effectively with the ALMATEC diaphragm monitoring.

A capacitive diaphragm sensor is mounted in the muffler [25] of the pump, which registers any liquid approaching the sensor, no matter whether the liquid is conductive or not. Hence, a fast reaction to a damage of a diaphragm becomes possible. However, it has to be considered, that the diaphragm monitoring possibly cannot prevent that liquid can leave the pump via the muffler. For higher safety requirements the ALMATEC barrier chamber system (optional equipment code BS) is recommended. In case of humid surrounding air a false alert may occur despite operating the pump with dried compressed air.

The diaphragm monitoring system is available in two variations:

- D 1 Diaphragm sensor (Namur), also for explosion proof area
- D 3 Diaphragm monitoring system complete with sensor and controller

The diaphragm sensor can either be connected to an existing controller with Namur inlet (code D 1) or to the controller included (code D 3). The wiring diagram and technical data can be found on the controller itself. For further details, please refer to the data delivered by the manufacturers of the components.

The controllers have to be installed in a suitable cabinet.

Spare part list Diaphragm monitoring					C 10	C 15	C 25	C 40	C 50
Code	Pos	Qty.	Description	Material	Part-No.	Part-No.	Part-No.	Part-No.	Part-No.
D1	51	1	Diaphragm sensor, Namur	diverse	1 00 773 99	1 00 773 99	1 00 773 99	1 00 773 99	1 00 773 99
D3	51	1	Diaphragm sensor, Namur	diverse	1 00 773 99	1 00 773 99	1 00 773 99	1 00 773 99	1 00 773 99
	-	1	Controller	diverse	1 00 370 99	1 00 370 99	1 00 370 99	1 00 370 99	1 00 370 99

Pumps with PTFE-diaphragms and FEP gaskets (Extra equipment code FP)

FEP/FKM-Gaskets cover a very wide range of applications via their wide-spread chemical resistance (please check chemical resistance).

Spare part list for Extra equipment code FP					C 10	C 15	C 25	C 40	C 50
Code	Pos	Qty.	Description	Material	Part-No.	Part-No.	Part-No.	Part-No.	Part-No.
FP	3	2	O-ring, valve stop discharge valve	FEP/FKM	9 19 624 59	9 24 625 59	9 38 626 59	9 57 627 59	9 76 628 59
	9	2	O-ring, plug side housing	FEP/FKM	9 20 602 59	9 25 610 59	9 40 613 59	9 62 634 59	9 79 353 59
	13	4	O-ring, manifold	FEP/FKM	9 15 630 59	9 20 631 59	9 33 632 59	9 50 633 59	9 62 634 59

Centre block in PA-conductive (Extra equipment code A)

For using PTFE-pumps from C-Series beyond 80°, pumps with extra option Code “A” are equipped with a centre block in conductive PA.

Spare part list for Extra equipment code A					C 10	C 15	C 25	C 40	C 50
Code	Pos	Qty.	Description	Material	Part-No.	Part-No.	Part-No.	Part-No.	Part-No.
A	15	1	Center block	PA-conductive	17 10 040 53X	17 15 040 53X	17 25 040 53X	17 40 040 53X	17 50 040 53X

NPT-threaded air inlet (Extra equipment code AN)

C-Series-Pumps with option Code “AN” are equipped with an alternative air inlet with female NPT-thread.

Spare part list for Extra equipment code AN					C 10	C 15	C 25	C 40	C 50
Code	Pos	Qty.	Description	Material	Part-No.	Part-No.	Part-No.	Part-No.	Part-No.
AN	17	1	Air inlet, NPT-threaded	PETP	1 08 147 84	1 15 147 84	1 15 147 84	1 40 147 84	1 40 147 84

DIMENSIONAL DRAWING

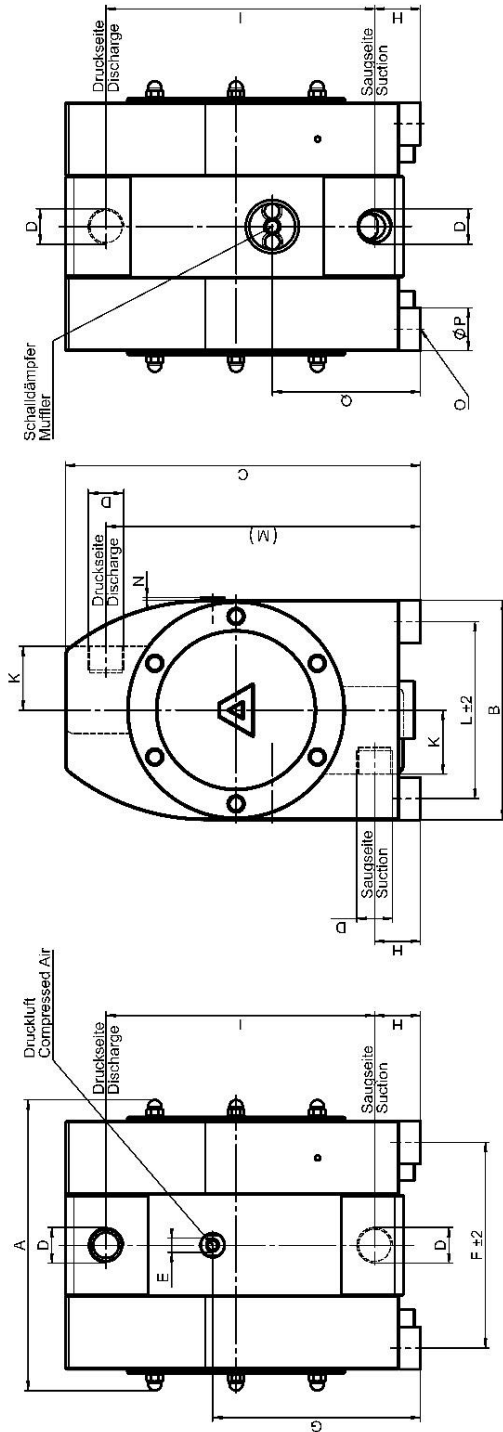

	A	B	C	D	E	F	G	H	I	K	L	M	N	O	P	Q
C 10	155	110	177	NPT 3/8"	R 1/8"	92	94	30	128	30	80	158	-	M6	25	94
C 10-1	155	110	174	NPT 3/8"	R 1/8"	92	91	23	132	30	80	155	-	-	25	91
C 10-2	155	110	179	NPT 3/8"	R 1/8"	92	96	28	132	30	80	160	-	-	25	96
C 15	203	156	253	NPT 1/2"	R 1/4"	131	155,5	43	162	46	116	225	-	M8	40	105,5
C 15-1	203	156	253	NPT 1/2"	R 1/4"	131	155,5	35	190	46	116	225	-	M8	40	105,5
C 15-2	203	156	253	NPT 1/2"	R 1/4"	131	155,5	43	162	46	116	235	-	M8	40	105,5
C 25	273	206	333	NPT 1"	R 1/4"	193	195	52	243	60	166	295	3	M8	40	139
C 25-1	273	206	333	NPT 1"	R 1/4"	193	195	43	252	60	166	295	3	M8	40	139
C 25-2	273	206	353	NPT 1"	R 1/4"	193	215	63	252	60	166	315	3	M8	40	159
C 40	368	272	448	NPT 1.5"	R 1/2"	278	230	67	359	75	222	406	7	M10	50	230
C 40-1	368	272	453	NPT 1.5"	R 1/2"	278	235	68	343	75	222	411	7	M10	50	235
C 40-2	368	272	453	NPT 1.5"	R 1/2"	278	235	72	344	75	222	416	7	M10	50	235
C 50	452	352	562	NPT 2"	R 1/2"	354	295	73	437	83	302	510	7	M10	50	285
C 50-1	452	352	567	NPT 2"	R 1/2"	354	291	76	440	83	302	518	7	M10	50	291
C 50-2	452	352	567	NPT 2"	R 1/2"	354	291	75	440	83	302	515	7	M10	50	291

	A	B	C	D	E	F	G	H	I	K	L	M	N	O	P	Q
C 10	6.1	4.3	7	NPT 3/8"	BSP 1/8"	3.6	3.7	1.2	5	1.2	3.1	6.2	-	M6	1	3.7
C 10-1	6.1	4.3	6.9	NPT 3/8"	BSP 1/8"	3.6	3.6	0.9	5.2	1.2	3.1	6.1	-	-	1	3.6
C 10-2	6.1	4.3	7	NPT 3/8"	BSP 1/8"	3.6	3.8	1.1	5.2	1.2	3.1	6.3	-	-	1	3.8
C 15	8	6.1	10	NPT 1/2"	BSP 1/4"	5.2	6.1	1.7	7.2	1.8	4.6	8.9	-	M8	1.6	4.2
C 15-1	8	6.1	10	NPT 1/2"	BSP 1/4"	5.2	6.1	1.4	7.5	1.8	4.6	8.9	-	M8	1.6	4.2
C 15-2	8	6.1	10	NPT 1/2"	BSP 1/4"	5.2	6.1	1.7	7.6	1.8	4.6	9.3	-	M8	1.6	4.2
C 25	10.7	8.1	13.1	NPT 1"	BSP 1/4"	7.6	7.7	2	9.8	2.4	6.5	11.6	0.1	M8	1.6	5.5
C 25-1	10.7	8.1	13.1	NPT 1"	BSP 1/4"	7.6	7.7	1.7	9.9	2.4	6.5	11.6	0.1	M8	1.6	5.5
C 25-2	10.7	8.1	13.9	NPT 1"	BSP 1/4"	7.6	8.5	2.5	9.9	2.4	6.5	12.4	0.1	M8	1.6	6.3
C 40	14.5	10.7	17.8	NPT 1.5"	BSP 1/2"	10.9	9.1	2.8	13.3	3	8.7	16	0.3	M10	2	9.1
C 40-1	14.5	10.7	17.8	NPT 1.5"	BSP 1/2"	10.9	9.3	2.7	13.5	3	8.7	16.2	0.3	M10	2	9.3
C 40-2	14.5	10.7	17.8	NPT 1.5"	BSP 1/2"	10.9	9.3	2.8	13.5	3	8.7	16.4	0.3	M10	2	9.3
C 50	17.8	13.9	22.1	NPT 2"	BSP 1/2"	13.9	11.3	2.9	17.2	3.3	11.9	20.1	0.3	M10	2	11.3
C 50-1	17.8	13.9	22.3	NPT 2"	BSP 1/2"	13.9	11.5	3.1	17.3	3.3	11.9	20.4	0.3	M10	2	11.5
C 50-2	17.8	13.9	22.3	NPT 2"	BSP 1/2"	13.9	11.5	3	17.3	3.3	11.9	20.3	0.3	M10	2	11.5



Subject to change without notice, 2022/01

PSG Germany GmbH
 Hochstraße 150-152 · 47228 Duisburg · Germany
 Telephone +49 (0) 20 65 / 89 2 05 - 0 · Telefax +49 (0) 20 65 / 89 2 05 - 40
<http://www.psgdover.com> · e-mail: psg-germany@psgdover.com