

Liquid Traps

Compressors handling gasses that contain condensates or other liquids must be protected from entry of the liquid. **LIQUID IN A COMPRESSOR CYLINDER CAN CAUSE DESTRUCTION OF THE COMPRESSOR.**

A liquid trap should be installed in the suction line near the compressor to stop liquid before it can enter the compressor. The trap provides a volume in which the liquid may collect. A mechanical float may be used to physically block the suction line in the event of high liquid, or an electrical float switch may be used to stop the compressor motor.

Blackmer offers a variety of liquid traps.

1. Standard on -TU and -LU mounting styles:

A non-code vessel fitted with a stainless steel float which will shut off the intake line to the compressor in the event of an excessive liquid level. A vacuum breaking valve is provided on the liquid trap head in case the trap closes and a vacuum develops between the compressor and the trap. A manual drain valve is provided.

2. Optional on -TU and -LU mounting styles:

The above trap may be fitted with an optional electric float switch to protect the compressor by stopping the compressor motor when a high liquid level is present in the liquid trap. The electric float switch may be used with or without the mechanical float described above.

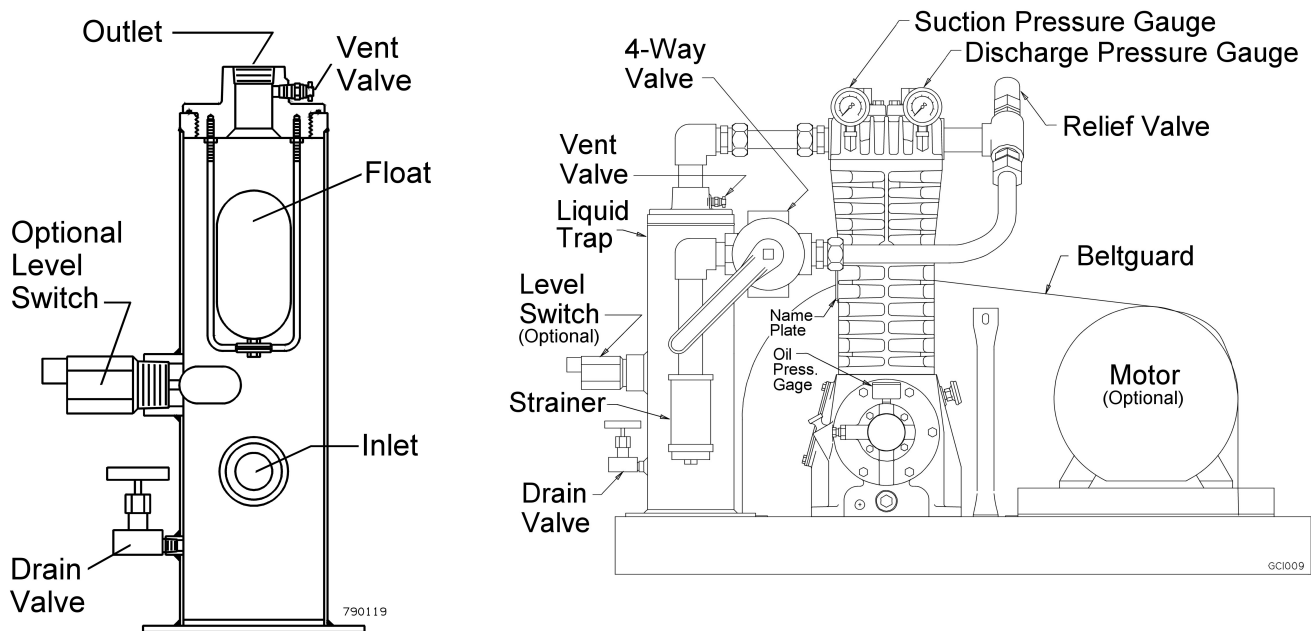

3. Standard on -LW, -LC, -TW and -TC mounting styles (see CB218):

For additional protection, a larger ASME code stamped vessel is used on these mounting styles. This liquid trap is typically fitted with two electric float switches for both a high liquid level alarm and shut down signal, a relief valve, and a 1" manual drain valve.

The ASME code vessel is particularly useful in systems with long suction lines which might accumulate too much liquid to be handled by one of the smaller traps. It is also needed if level gauges or automatic drain systems are required or if the customer insists on a code stamped vessel.

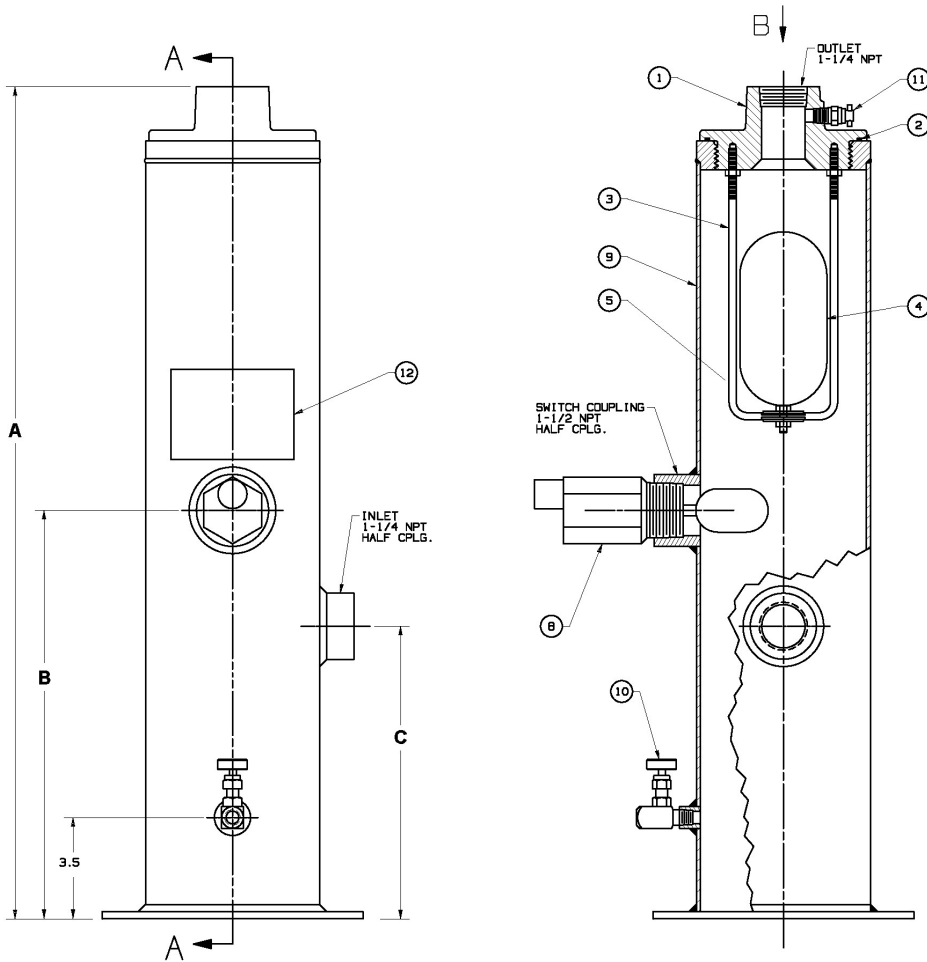

	Trap Part No.	
Dim	790039	790179
A	22.77"	30.87"
B	10.00"	16.25"
C	6.5"	12.25"
Total Volume	2.45 gal.	3.42 gal.
Volume to Switch Level	1.13 gal.	1.46 gal.

All traps are hydrostatically tested to 500 psi.

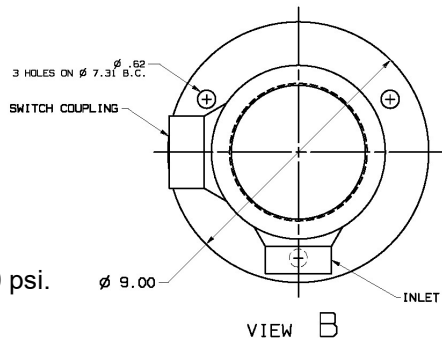

Ref.	Part No.	Description
1	--	Cage Adapter (Ductile Iron)
2	790071	O-Ring (Buna) (790239 PTFE, 790241 FKM 794171 Neoprene, 790245 EPR)
3	--	Float Cage Assembly (Steel)
4	790054	Float (Stainless Steel for 0.4 Specific Gravity)
8	790017	Optional Float Switch (Stainless Steel Float, 0.4 Specific Gravity)
9	--	Shell Assembly, 6" O.D. x 0.120" Hot Rolled, Electric Resistance Weld Grade 1010 Carbon Steel, ASTM 513, Type 1
10	790583	Needle Valve (Steel, 1/4" NPT)
11	790022	Vent Valve (Steel, 1/4" NPT)
12	790046	Label