

ML Series

HEAVY-DUTY MODULAR SLIDING VANE PUMPS | PRODUCT BROCHURE



Blackmer

Where Innovation Flows

THE FLEXIBLE PUMP SOLUTION

Blackmer®



Blackmer® ML Series Sliding Vane Pump Heavy-Duty Customizable Transfer Pumps

The ML Series Sliding Vane Pumps are heavy-duty, and highly customizable transfer pumps. These 4-inch pumps feature a flow rate of 35 to 590 gpm (132 to 2,233 L/min) and feature an open rotor design that aids in the transfer of high viscosity fluids. The ML Series come in two base models that feature different interchangeable hub assemblies– MLX Model, an external sleeve bearing pump and MLN Model an internal sleeve bearing pump. The removable hub assembly allows quick access to the bearing and sealing areas for routine inspection, without removing the entire pump head.

Due to their ductile iron construction, ML Series Sliding Vane Pumps are capable of handling heavy-duty applications and continuous operation. The ML Series is highly customizable and offers several optional configurations, such as:

- Hardened end discs, and liners components for increased durability against premature wear from particulates transfer
- Jacketed pump head, for transfer of higher temperature fluids
- Relief valve with internal inlet return or external return connection
- Variety of mechanical seal options for both models and also shaft packing option for the MLN Model
- Reduced flow liner allows for a larger range of applications by lowering flow rates without decreasing the pump's operating speed
- Various vane options optimized for specific fluid handling needs

The ML Series also allows for use of any third-party commercial mechanical seals to be used for specific sealing requirements. ML Series Pumps are fitted with many replaceable wear parts like vanes, push rods, liners, and end discs, allowing for easy rebuilding of the pump, without removing the pump from the piping.

ML Series Sliding Vane Pumps | Design Features

MLX

Modular, Replaceable Liner, External Bearing Pump

Offering four different mechanical seal options, MLX Model Pumps are well suited for single mechanical seal use and excel in the transfer of clean liquids from light non-lubricating to medium viscosity fluids, up to 21,000 cSt (100,000 ssu). External sleeve bearings reduce pump wear due to balanced shaft load, and decrease required maintenance because the greased bearing housing is external from the working fluid.

MLN

Modular, Replaceable Liner, Internal Sleeve Bearing Pump

Based on your needs, MLN Model Pumps offer three different sealing options – packing, single mechanical seal, and triple lip seal. Third party mechanical seals can also be used for specific sealing requirements. The MLN Model Pumps are best used for transfer of demanding liquids, meaning fluids with solids and abrasives up to 0.4 mm, ranging up to high viscosity fluids. Some configurations allow for viscosity levels up to 108,000 cSt (500,000 ssu) and have a max temperature limit of 400°F (204°C).

Design Features, Options and Specifications

- **Vanes:** Available in a wide range of materials to match your fluid service. Standard pin lock design automatically alerts operator when vane replacement is needed, before excessive wear can occur.
- **Liner:** Replaceable for easy rebuilding of the pump chamber if ever necessary.
Optional: Hardened, wear-resistant liner is available for handling abrasive fluids.
- **End Discs:** Protect the heads from wear. Can easily be replaced if ever needed.
Optional: Wear-resistant end discs are available for highly abrasive fluids.
- **Rotor & Shaft:** Double ended for convenience of driving the pump in either direction.
- **Elastomers:** FKM is standard. Also available with PTFE.
- **Casing:** Thermal shock-resistant ductile iron is standard.
- **ANSI Compatible Flanges:** Standard on all models.
- **Drain Plugs:** Standard, allow for easy draining.
- **Jacketed Heads:** For circulation of steam or hot oil for heating highly viscous fluids, or circulation of coolant for controlling bearing temperature.
- **2-Way Relief Valve:** Detachable, with special back-to-tank feature or internal bypassing.
- **Base Mounted Unit Assemblies:** Complete with pump, base, gear reducer, couplings and coupling guards, ready to accept a standard NEMA motor. All units are available with or without motors or drives.

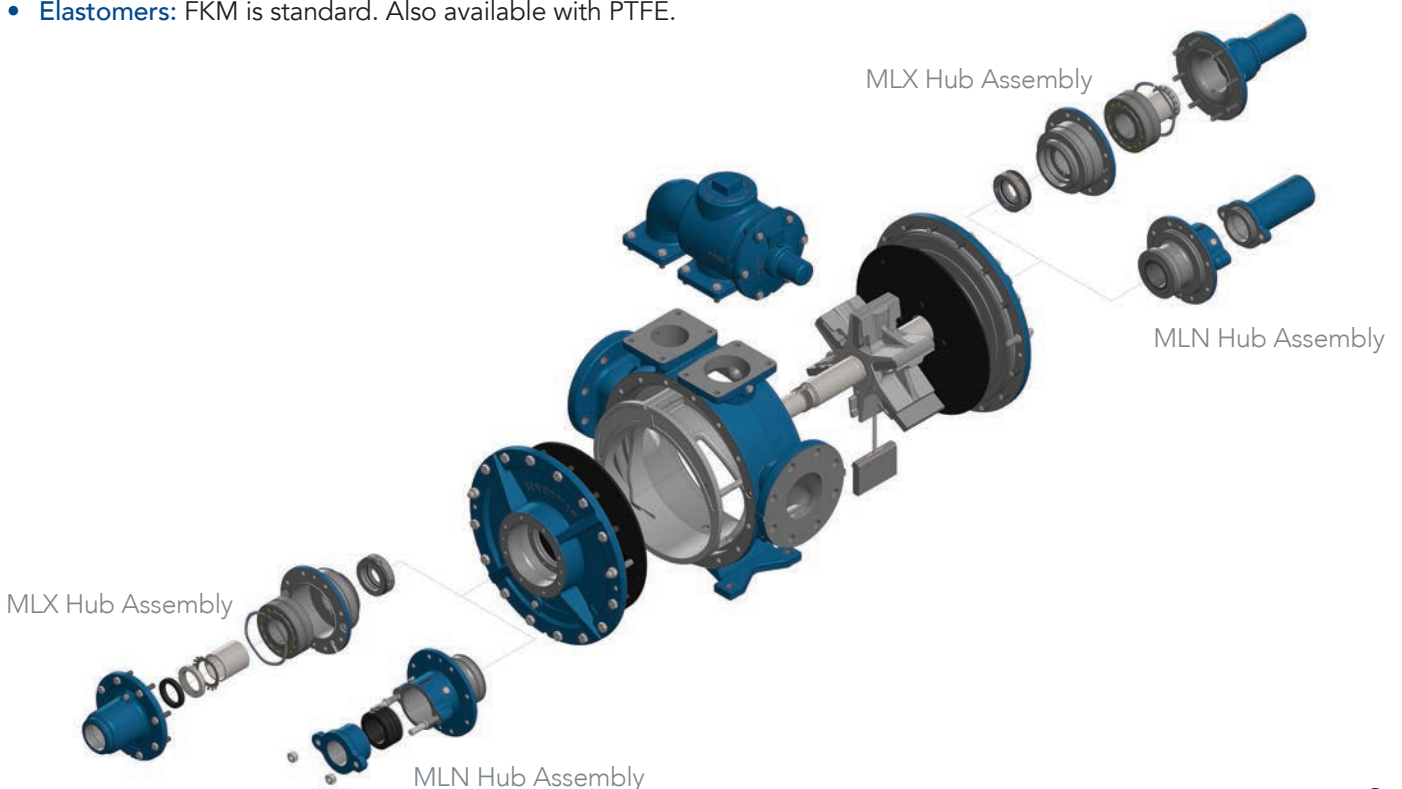

THE FLEXIBLE PUMP SOLUTION

Blackmer® | Sliding Vane Technology

About Sliding Vane Technology

Utilizing the unique sliding vane design of Blackmer, these positive displacement rotary vane pumps offer the best combined characteristics of sustained high level performance, energy efficiency, trouble-free operation and low maintenance cost.

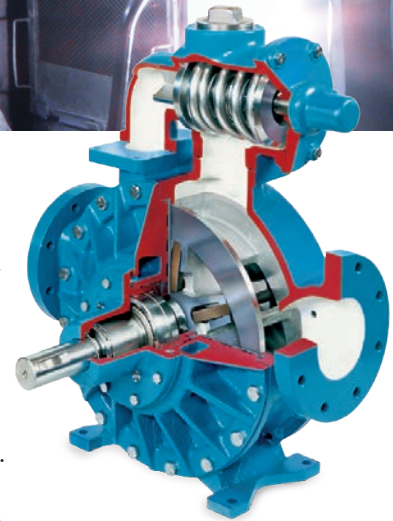

How Blackmer Sliding Vane Pumps Achieve High Efficiency

Blackmer Sliding Vane Pumps use a rotor with sliding vanes that draw the liquid in behind each vane, through the inlet port and into the pumping chamber. As the rotor turns, the liquid is transferred between the vanes to the outlet where it is discharged as the pumping chamber is squeezed down. Each vane provides a positive mechanical push to the liquid before it.

Vane contact with the chamber wall is maintained by three forces: (1) centrifugal force from the rotor's rotation, (2) push rods moving between opposing pairs of vanes, and (3) liquid pressure entering through the vane grooves and acting on the rear of the vanes.

Each revolution of a Blackmer Sliding Vane Pump displaces a constant volume of fluid. Variance in pressure has minimal effect. Energy-wasting turbulence and slippage are minimized and high volumetric efficiency is maintained.

Advantages Of Sliding Vane Technology:

- Unique sliding vane pump design self-adjusts for wear to maintain flow rates
- Excellent at self-priming, eliminates expensive priming systems
- Extended dry-run capability, eliminates nuisance current monitoring systems
- Sliding vane design provides sustained performance and trouble-free operation
- Easy maintenance: vanes, liners, and discs can be easily replaced without removing the pump from the piping system
- High suction lift abilities that exceed 25 feet (7.6 meters)
- and line-stripping capabilities to completely empty tanks, and piping of fluid
- Low maintenance and low life-cycle costs, pumps are renewable and repairable
- Solids handling, provided by large displacement and slow internal velocities
- Thin to thick fluid viscosity flexibility, eliminates expensive heating systems
- Highly efficient, sliding vane pumps require less horsepower than other pumps, meaning spending less on motors initially and less on electricity to power the pump

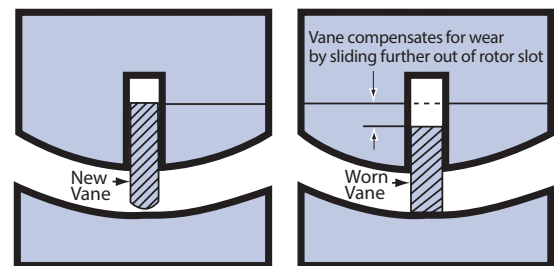
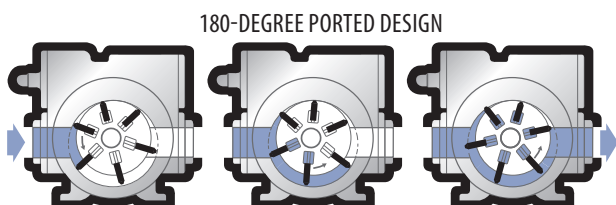

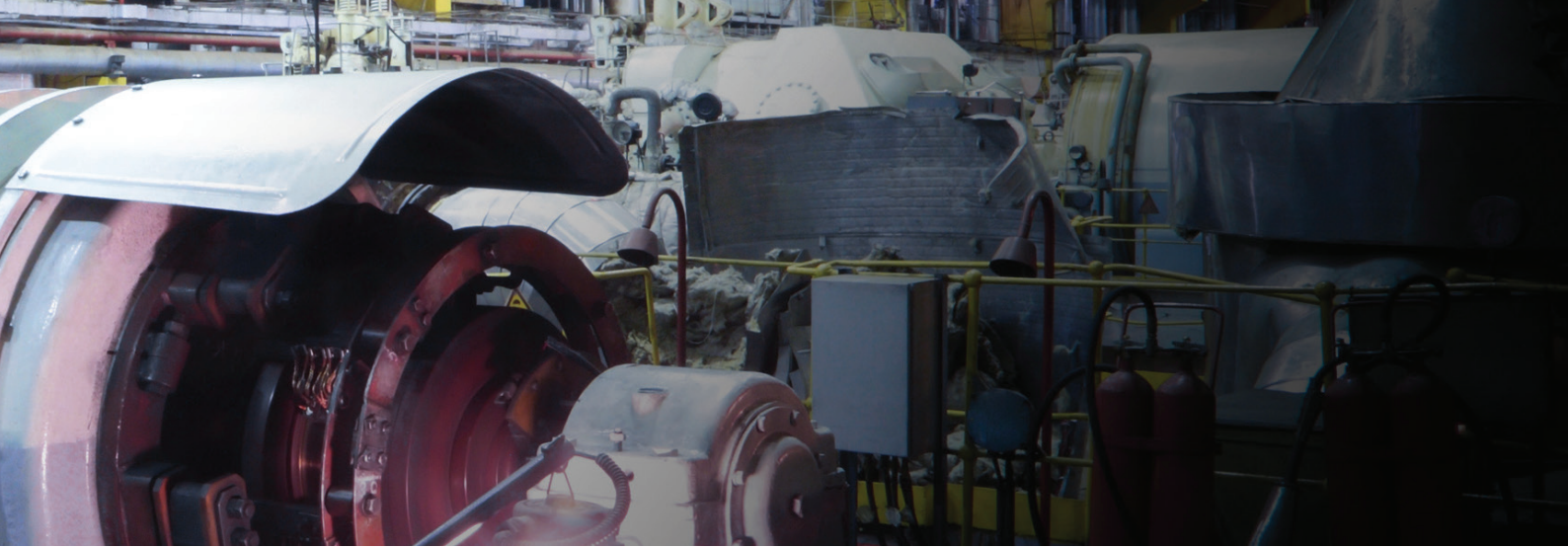

ML Series | Performance & Specifications

Performance Data

	30	500	2,000	5,000	20,000	50,000	100,000	200,000 ²	500,000 ²
ssu	30	500	2,000	5,000	20,000	50,000	100,000	200,000 ²	500,000 ²
cSt	1.0	110	630	2,200	4,250	10,500	21,000	44,000	108,000
rpm	600	600	600	600	500	300	200	155	68
gpm ¹	550	583	583	583	485	291	193	149	64
m ³ /h ¹	125	132	132	132	110	66	44	34	14
hp ¹	21.4	24.2	28.6	35.0	31.7	23.1	14.1	15.6	6.5

Horsepower (hp) and nominal flow rates are for the conditions specified at 50 psi (3.5 bar) differential pressure.

Refer to performance curves for capacities and horsepower at other operating conditions.

¹ Reduced liner models are available with flow and hp of about 75% of the standard models.

² Note: Viscosity for the MLX4 pump model is limited to 100,000 ssu (21,000 cS).

Operating Limits

Pump Model	Nominal Flow Rate Range	Viscosity	Maximum Operating Temperature	Min./Max. Speed	Maximum Working Pressure	Maximum Differential Pressure
MLX4	35 - 590 gpm (132 - 2,233 L/min)	21,000 cSt (100,000 ssu)	-25°F to 300°F (-32°C to 149°C)	68 - 600 rpm	250 psi (17.2 bar)	200 psi (13.8 bar)
MLN4	35 - 590 gpm (132 - 2,233 L/min)	108,000 cSt (500,000 ssu)	-25°F to 400°F (-32°C to 204°C)	68 - 600 rpm	225 psi (15.5 bar)	200 psi (13.8 bar)

Maintenance and Rebuild Kit Part Numbers

Pump Model	Maintenance Kit	Rebuild Kit	
MLX4	898982	899082	Not available for Reduced Flow or Wear Resistant Hardened configurations
MLN4	899218	899118	Not available for Reduced Flow Configurations

ML Series | Performance & Specifications

Nominal Flow Rate Range @ 60 Hz

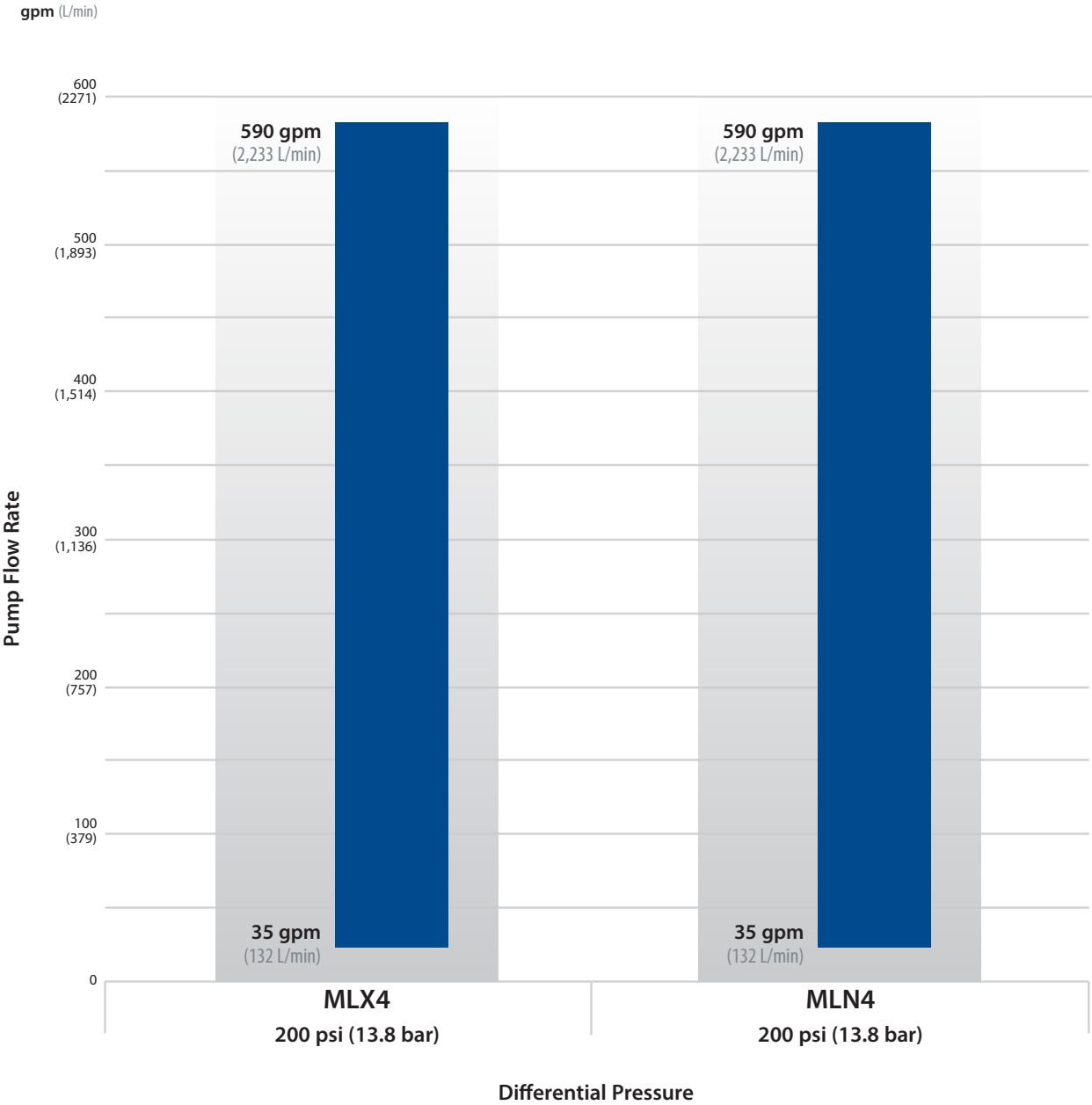

ML Series | Dimensions

ML4

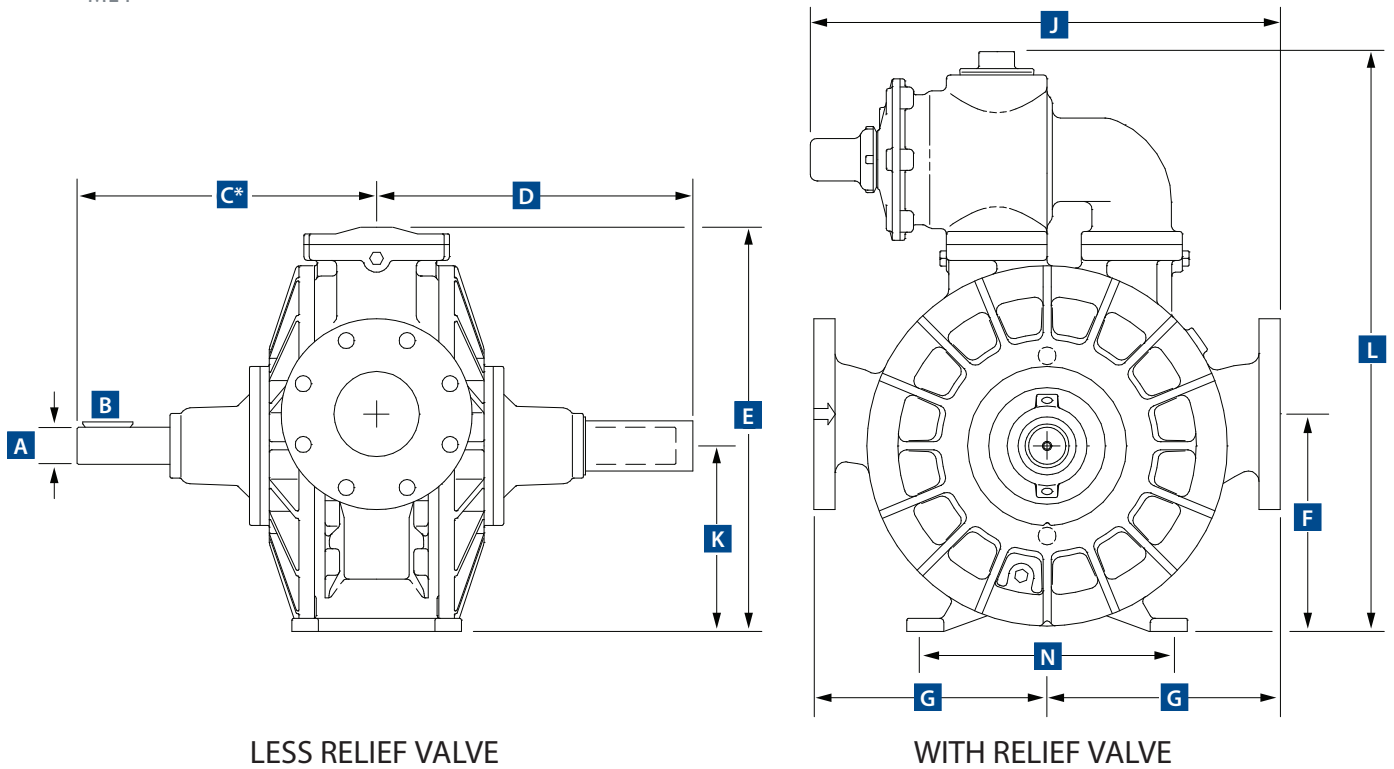

LESS RELIEF VALVE

WITH RELIEF VALVE

Pump Model		A	B	C*	D	E	F	G	J	K	L	M	N
ML4	in.	1 ³ / ₄	³ / ₈	14 ¹ / ₈	15 ¹ / ₄	19 ¹ / ₁₆	10 ¹ / ₄	11	22 ¹ / ₄	8 ³ / ₄	27 ³ / ₈	6 ¹ / ₂	12
	mm	-	-	359	403	484	260	279	565	222	695	165	305

* All ML4 pumps have double ended shafts.

Pump Model	Approx. Wt. With Relief Valve	Approx. Wt. Less Relief Valve
ML4	445 lbs.	393 lbs.
	202 kg	179 kg

Note: ANSI compatible flanges.



PSG Grand Rapids
1809 Century Avenue SW
Grand Rapids, MI 49503-1530
USA
P: +1 (616) 241-1611
F: +1 (616) 241-3752
info@blackmer.com
blackmer.com



Where Innovation Flows

106-001_A4 12/20

Authorized PSG® Partner:

Copyright 2020 PSG®, a Dover company