

Centrifugal Pumps

HEAVY-DUTY LARGE VOLUME PUMPS | PRODUCT BROCHURE

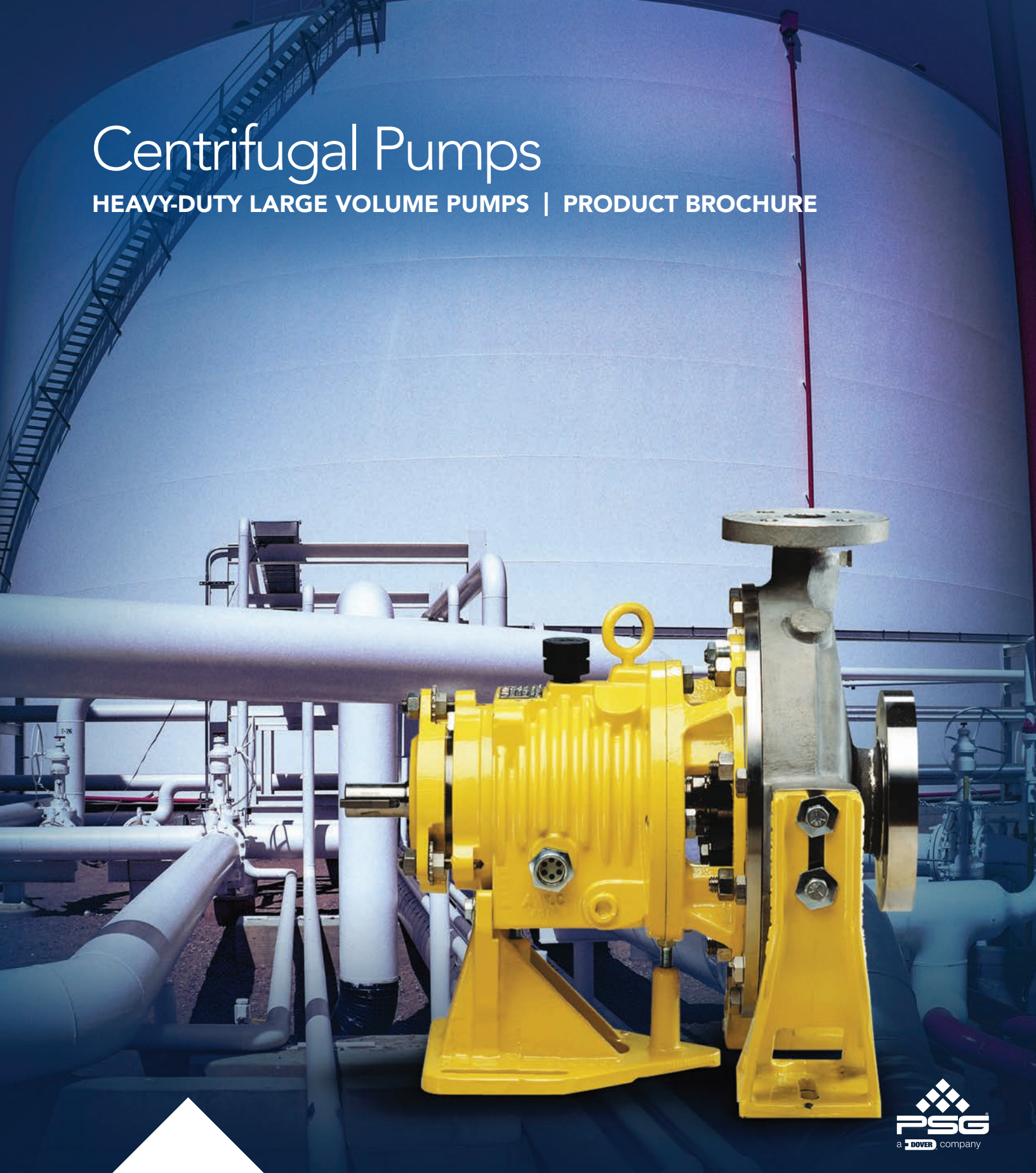

Blackmer

Where Innovation Flows



Blackmer® Centrifugal Pumps stand alone in the crowded centrifugal space. Why? Because Blackmer Centrifugal Pumps are **ANSI PLUS** pumps. That means that they are ANSI pumps that comply with key parts of the API 610 standard, bringing a full set of reliability and ease-of-use features not found in any other ANSI pump.

HEAVY-DUTY
CENTRIFUGAL PUMPS
FOR SEVERE &
CONTINUOUS DUTY

Blackmer® Centrifugal Pumps

Designed and built to exacting standards, heavy-duty Blackmer Centrifugal Pumps are highly reliable and perform exceptionally well in safely transferring critical and valuable fluids in the harshest of service conditions. Blackmer guarantees our centrifugal pumps with our unmatched performance assurance guarantee – five years for the power end and one year for the mechanical seal.

Blackmer is confident in offering these performance assurance guarantees because our centrifugal pumps are designed and constructed to meet the API 610 standard of a minimum 20-year service life and three years of uninterrupted operation. With this standard applied, Blackmer Centrifugal Pumps were overbuilt to protect and support the mechanical seal. This is achieved by providing the stiffest solid shaft on the market, oversized bearings, and numerous other features that protect the pump in even the most aggressive operating conditions. By offering maximum reliability, uptime and extended pump life, Blackmer Centrifugal Pumps are the pumps to turn to when all others fail.

Designed for full curve operation, Blackmer Centrifugal Pumps offer the widest window of operations off the Best Efficiency Point (BEP) of any conventional centrifugal pump. With flow rates up to 4,500 gpm (17,034 L/min) and a standard temperature range of -40° to 400°F (-40° to 204°C), Blackmer Centrifugal Pumps can withstand severe and continuous operating conditions, where uptime is vital for operations with factory consultation.



Blackmer® Centrifugal Pumps | Key Differentiators

Wider Window of Operation Off the BEP (Best Efficiency Point)

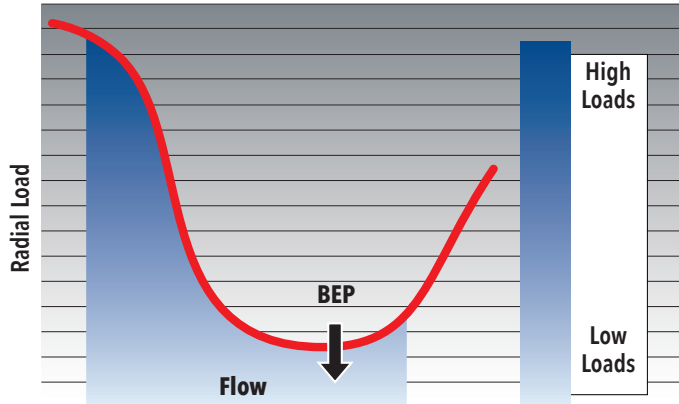

Many processes demand operation off the BEP where higher loads can create damaging vibration.

Process Pump Challenges:

- Due to process changes and variations, the majority of process pumps operate off the BEP where radial loads create high stresses
- Conventional pumps are prone to damaging shaft vibration under off-BEP conditions
- Seal and bearing failures result from vibration damage

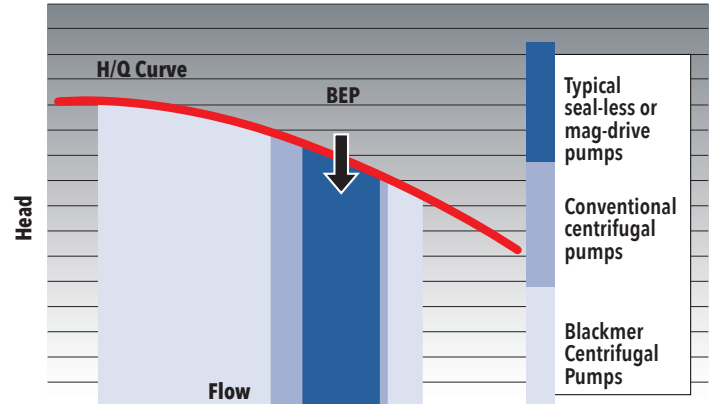

Blackmer Centrifugal Pumps resist vibration for a larger operational window off the BEP and greater reliability.

Blackmer® Centrifugal Pumps Are The Solution:

- Heavy-duty design for the toughest applications in the process industry
- Blackmer Centrifugal Pumps are designed to prevent vibration under high radial loads
- Blackmer Centrifugal Pumps offer the widest operational window off the BEP of any standard process pump
- Seals and bearings last longer for greater system reliability
- When your process demands that pumps vary from the BEP, Blackmer Centrifugal Pumps will save you money and prevent lost production

Warranty & Performance Assurance

Blackmer offers a five-year power end, and one-year mechanical seal performance assurance guarantee – If any centrifugal pump power end component fails, a free replacement component will be provided, and if a mechanical seal fails, a spare parts kit will be provided. Blackmer stands behind our Centrifugal Pumps because we know they were built to last and operate in the most severe environments without failing.

Design Standards

Blackmer Centrifugal Pumps are used by Military and Naval marine vessels around the world, on land and sea – Under the most difficult conditions imaginable. Blackmer Centrifugal and Vane Pumps are approved by the US Military. In fact, these pumps can be found in all US Navy Surface Combatant Vessels providing rock-solid reliability when and where it is needed the most. Our pumps have met numerous military standards for over 50 years.

Meets the following military specifications standards:

- MIL-S-901-D
- MIL-STD-167
- MIL-P-19131
- ASTM DF1510

BLACKMER® CENTRIFUGAL PUMPS

Reliability Features

Blackmer® Centrifugal Pumps are designed specifically to operate in severe applications and resist vibration that would otherwise cause frequent maintenance shutdowns.

- 1 Solid Shaft** (no sleeve) with minimal overhang provides superior resistance to deflection. Lowest L3/D4 ratio in the industry.
- 2 Labyrinth Seals** provide non-wearing lifetime protection for radial and thrust bearings
- 3 Oversized 7310 (pair) Angular Contact Thrust Bearings** are standard for high thrust capability, as required by **API 610** specifications
- 4 Positive Locking Thrust Bearing Retainer Cover** for maximum bearing holding power and minimum axial movement
- 5 Large Bore Seal Chamber** available with optional throat bushing
- 6 Optional Seal Chamber Jacket** for cooling the mechanical seal
- 7 Centerline Casing Support Legs** are adjustable for pipe variations and minimize heat effects, as required by **API 610** specifications
- 8 Rabbet for C-Frame (NEMA) or D-Flange (IEC) Motor Adaptor** provides for automatic mechanical motor alignment without special tools or excessive labor
- 9 Standard Mechanical Seals Can Be Installed On All Blackmer Centrifugal Pump Frames.** Frame A offers an optional seal chamber jacket for cooling the mechanical seal
- 10 Impeller** is a single piece casting with solid hub, while also threaded to the shaft. Impeller lock bolts and keyed impellers available as options – **API 610**
- 11 Bushing** options include carbon, polyurethane and SpiralTrac¹

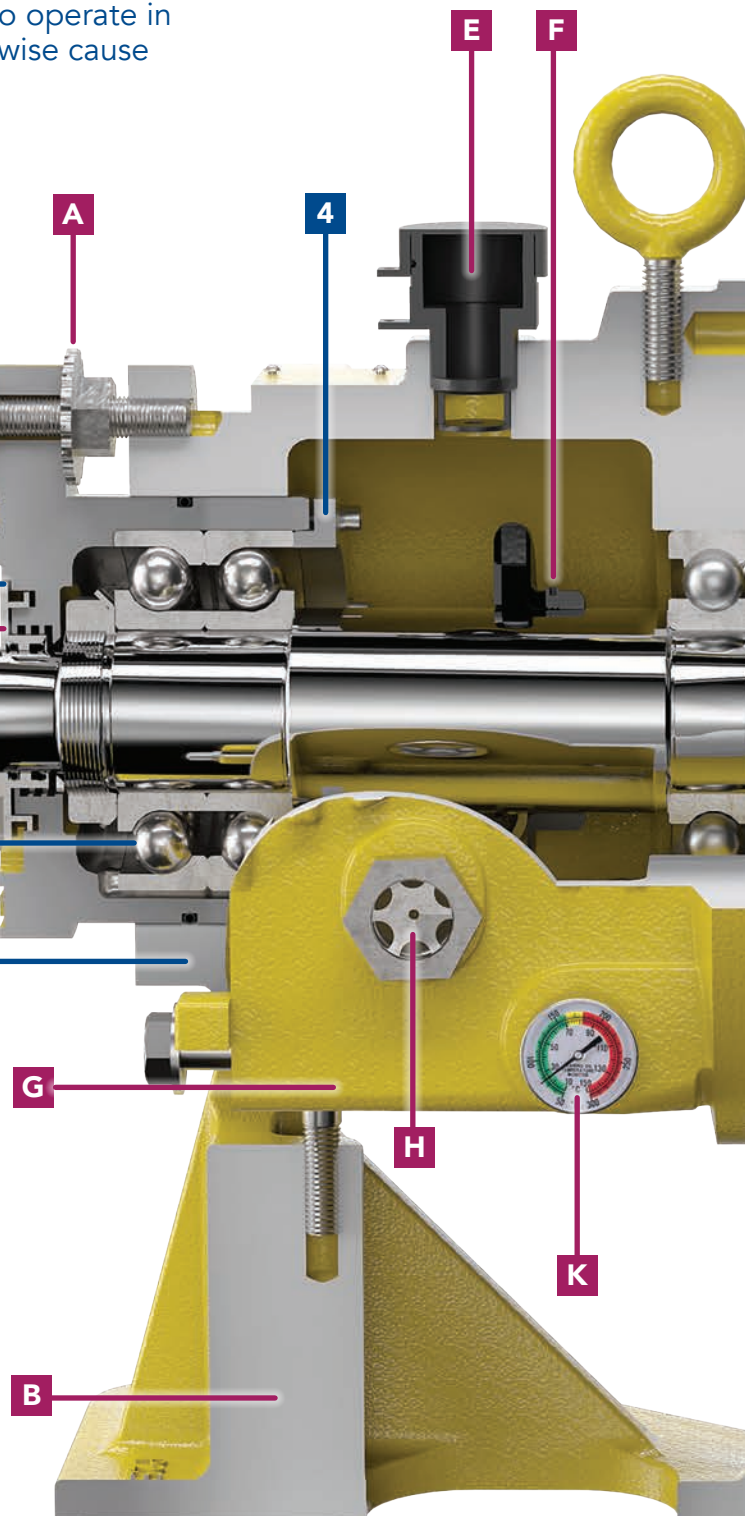

¹SpiralTrac is a registered trademark of the manufacturer, EnviroSeal Engineering Products Ltd., Waverly, Nova Scotia

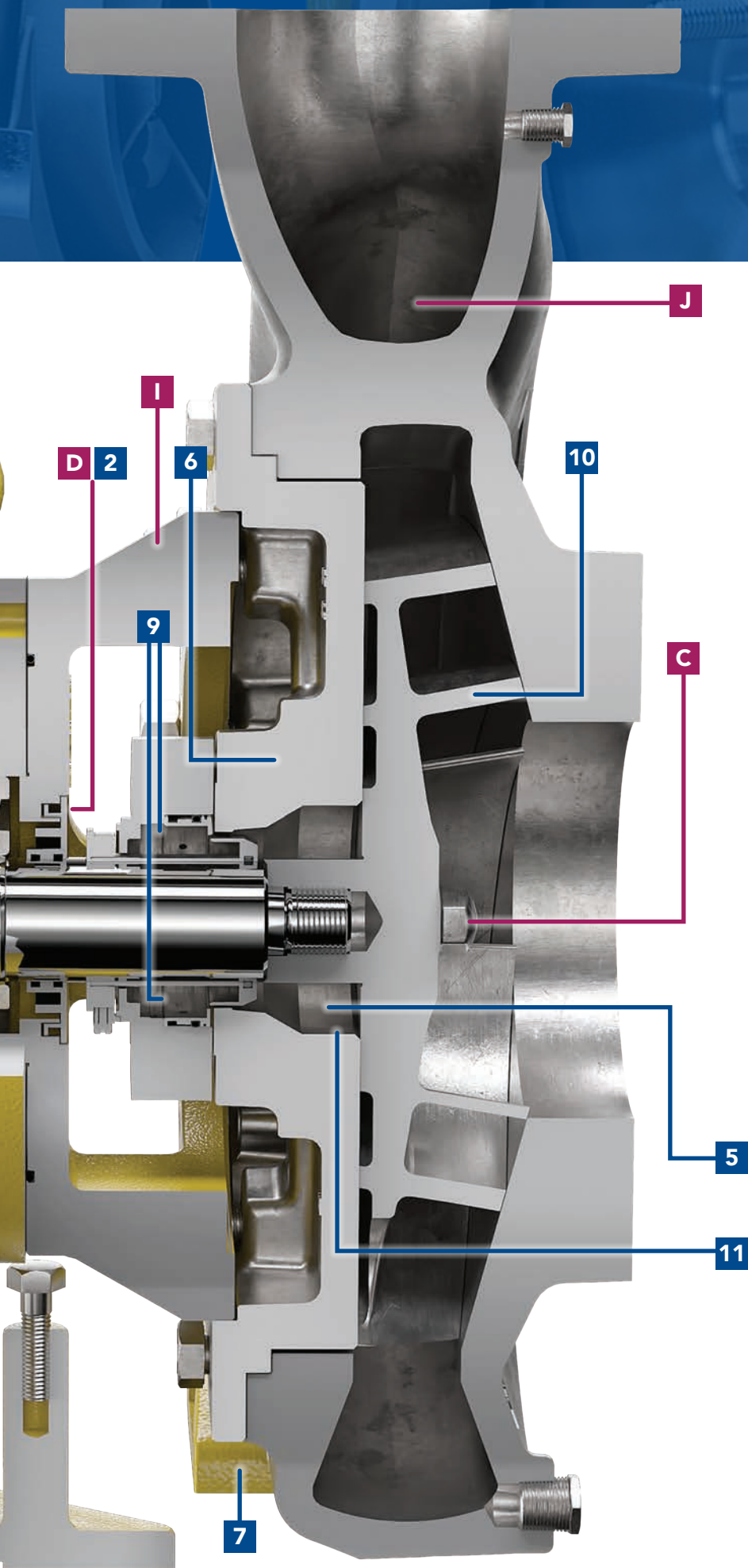

Ease of Use Features

Designed for pump operators, Blackmer® Centrifugal Pumps makes operation, maintenance, and repair simple with these ease of use features.

- A Micrometer Adjustment Nuts** simplify and ensure precise impeller setting for maximum efficiency
- B Full Support Rear Leg** assures bearing frame remains upright during pump disassembly
- C Cast-In Impeller Nut** makes removal easy
- D Labyrinth Seals** provide non-wearing lifetime protection for radial and thrust bearings
- E Large Oil Inlet** for easy filling of oil. Close fitting cover minimizes dirt and moisture entry
- F Flinger Filter** constantly cleans oil during pump operation – **API 610**
- G Two Magnetic Drain Plugs** are provided to maintain clean oil and are removable for insertion of cooling coil – **API 610**
- H Oil Sight Glass** for constant monitoring of oil level and condition
- I Frame A Adapter** has a 180° unobstructed opening for ease of maintenance
- J Casting Methods** State-of-the-art casting methods provide smoothest possible surfaces for highest efficiency
- K Optional Bearing Oil Temperature Monitor** indicates potential failure of bearings and/or lubrication by an increase in oil temperature

CENTRIFUGAL FOCUS AREAS

Blackmer® Centrifugal Pumps are designed around the seal, bearing and shaft, which account for 90% of failures for generic pumps.

Addresses, Solves, Fixes Common Centrifugal Pain Areas

About 90% of Centrifugal Pump failures are with the seal, bearing and shaft

Packing & Seal

We offer a 1-year mechanical seal guarantee. We are confident in our mechanical seals not failing because Blackmer® Centrifugal Pumps are designed and built to prevent this from happening:

- Our low to no deflection shafts are shorter and thicker than competing shafts, saving the mechanical seals from violent wear due to shaft deflection
- Large bore seal chamber lubricates, cleans and cools the seal to prevent premature seal failures. Our seal chambers are designed without a backstop, which eliminates dead space and allows the fluid to move in and move out keeping the mechanical seal face in a cleaner and cooler environment. Unlike traditional ANSI pumps where fluid and debris get trapped right in front of the mechanical seal face, building up with debris and heat which negatively impact the mechanical seal

Seal Chamber Jacket

This optional feature provides an API Plan 2 external cooling to the pump. This will prevent seal failure due to thermal shock, with sudden and drastic temperature changes which can crack the brittle mechanical seal faces.

Centerline Casing Support Legs

The centerline casing support legs allow Blackmer Centrifugal Pumps to operate in high temperatures of up to 400°F. The centerline casing support legs allow the pump to “float,” this design feature gives the pump room to expand both vertically and horizontally due to thermal expansion. This prevents the questionable thermal growth on the casing that happens with many other ANSI pumps which reduces the life and reliability of the mechanical seal.

C-Frame (NEMA) or D-Flange (IEC) Motor Adapter

The design of the C-Frame adapter eliminates any misalignment concerns, removing any unnecessary strain on the pumping elements – especially the mechanical seal. It increases pump reliability by reducing vibration and prolonging mechanical seal life.

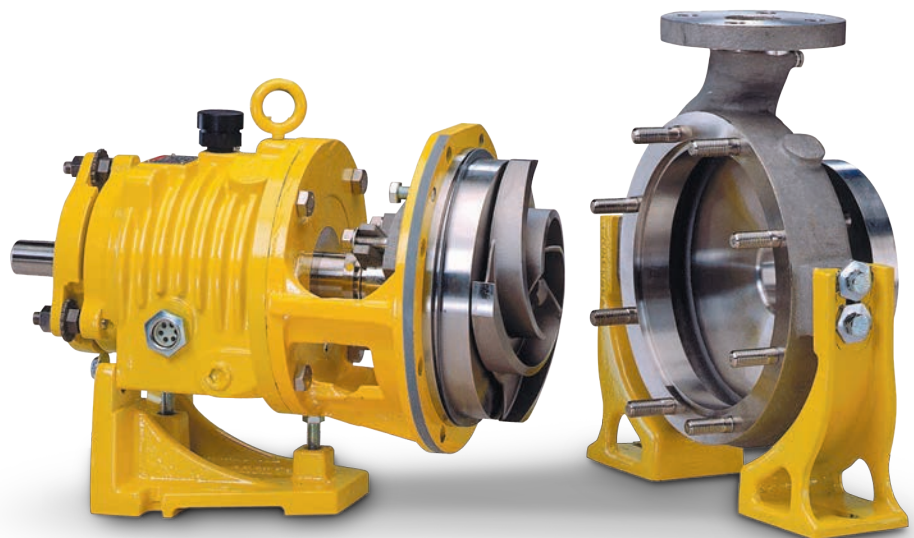



Bearings

Heavy-duty bearings with longer bearing life

- Blackmer® Centrifugal Pump bearings are one to two times size larger than generic bearings in ANSI centrifugal pumps
- Larger bearings, allow for greater load capacity and longer bearing life
- Bearings are retained, meaning the lock collar bolted retainer features eight bolts securing it to the thrust cartridge. This positively engages the thrust bearing and eliminates all the dynamic loads on the bearing.
- Bolt retainer cover locks thrust bearing into a cartridge for enhanced reliability
- Blackmer Centrifugal Pump angular collar thrust bearings are the same ones specified by API 610
- We are so confident our bearings will last, we offer a five year bearing guarantee

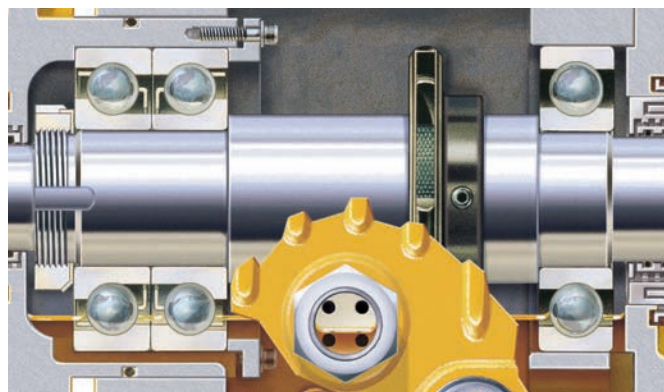

Shafts & Shaft Sleeve

- Blackmer Centrifugal Pump shafts are of one-piece solid design, which means no sleeves are used
- Shafts of Blackmer Centrifugal Pumps are much shorter and much thicker than competing ANSI pump shafts
- A shorter and thicker shaft, means low deflection (the degree to which a shaft is displaced under a load):
 - This prevents very common damage due to vibration
 - Increases stability at the seal area, improving operating life of the seal by reducing wear and pressure on the mechanical seal
 - Extends bearing life, because a short shaft overhang reduces bearing load

Blackmer Centrifugal Pumps feature the lowest shaft deflection ratios of all ANSI centrifugal pumps.

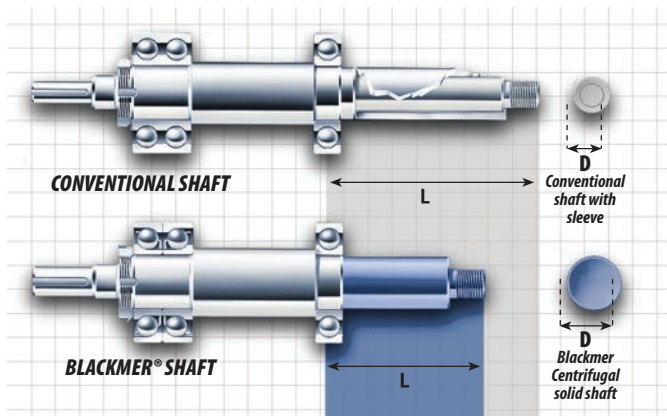

API 610 Features

Heavy-duty Blackmer Centrifugal Pumps are designed and constructed to provide maximum service life, comply with key parts of the API 610 standard for centrifugal pumps, and can be a cost-effective alternative to pumps that are in full compliance with the standard.

- Designed and constructed to meet the minimum standard of a 20-year service life and three years uninterrupted operation
- ANSI/ASME class 300 flanges option
- Self-venting top discharge with threaded casing drains are available as an option. Additional available options include flanged drains and side discharge. Flanged drains also an option. Optional side discharge is also available.
- Bearing housings can be removed from service without disturbing the driver. Sufficient cooling is achieved with a large oil sump and deep cooling fins. For extreme temperature operations, a copper coiling coil is an available option, and labyrinth seals are standard equipment.
- Offered with standard and optional materials that comply with the material classes

Blackmer® Centrifugal Pumps

Frame A/LD17 Pump

- LD17 configuration available for severe duty applications
- Lowest L3/D4 stiffness ratio of any competitive size pump 17 (.65) Frame LD17
- Frame A meets ASME/ANSI dimensional specifications

- Capacities up to 1,400 gpm (320 m³/hr)
- Operating temperature range from -40° to 400°F (-40° to 204°C)
- Military shock standard S901 Grade A
- High Temperature Series configurations available with some Frame A/LD17 sizes

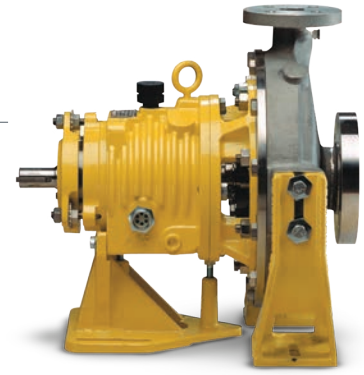

Frame A/LD17 (ASME/ANSI)

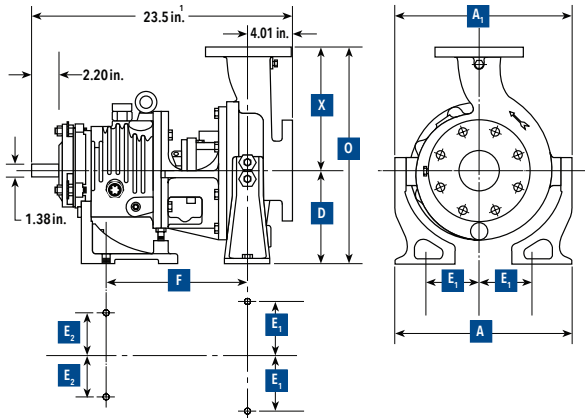

Frame A/LD17 (Metric)

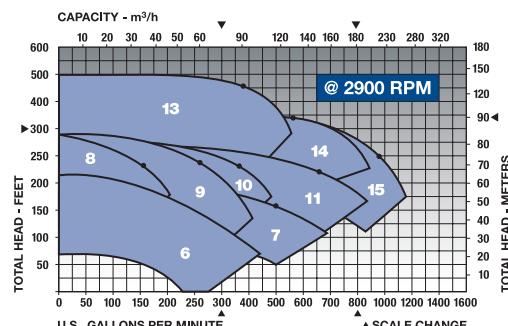
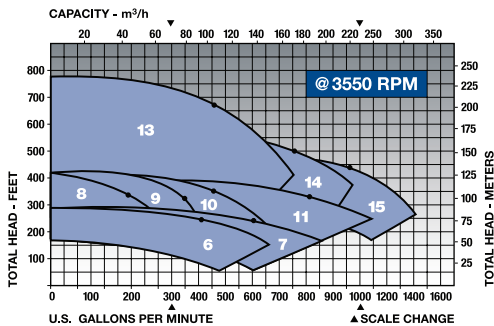
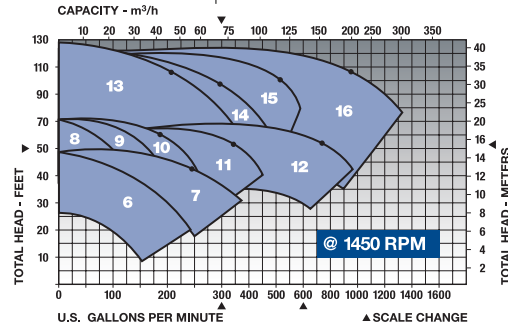
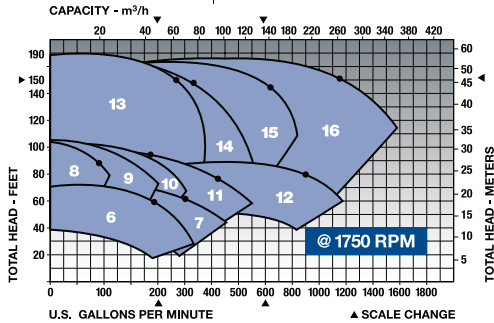
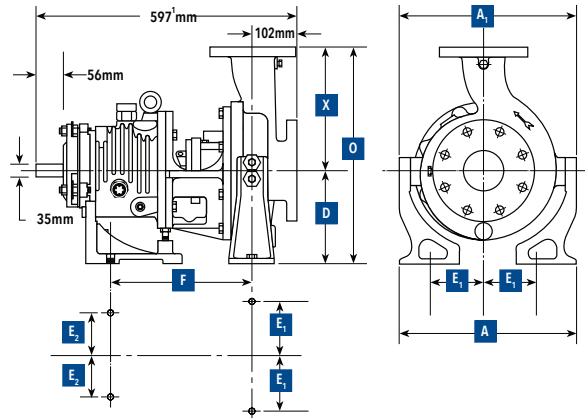

LD17 Pump - ASME/ANSI

Pump Size	Discharge	Suction	X	D	O	F	2E ₁	2E ₂	A	A ₁	
6	2 x 3-8	2.0	3.0	9.50	8.25	17.75	9.81	9.75	7.25	15.00	15.00
7	3 x 4-8	3.0	4.0	11.00	8.25	19.25	9.81	9.75	7.25	15.75	15.75
8	1 x 2-10	1.0	2.0	8.50	8.25	16.75	9.81	9.75	7.25	15.75	15.75
9	1.5 x 3-10	1.5	3.0	8.50	8.25	16.75	9.81	9.75	7.25	16.13	16.13
10	2 x 3-10	2.0	3.0	9.50	8.25	17.75	9.81	9.75	7.25	16.38	16.38
11	3 x 4-10	3.0	4.0	11.10	8.25	19.25	9.81	9.75	7.25	13.63	17.63
12	4 x 6-10	4.0	6.0	13.50	10.00	23.50	9.81	9.75	7.25	14.44	19.94
13	1.5 x 3-13	1.5	3.0	10.50	10.00	20.50	9.81	9.75	7.25	15.00	20.50
14	2 x 3-13	2.0	3.0	11.50	10.00	21.50	9.81	9.75	7.25	15.38	20.88
15	3 x 4-13	3.0	4.0	12.50	10.00	22.50	9.81	13.00	7.25	16.63	22.13
16	4 x 6-13	4.0	6.0	13.50	10.00	23.50	9.81	13.00	7.25	17.56	23.07

All dimensions are in inches.

LD17 Pump - Metric

Pump Size	Discharge	Suction	X	D	O	F	2E ₁	2E ₂	A	A ₁	
6	2 x 3-8	50	80	241	200	441	249	250	184	279	381
7	3 x 4-8	80	100	279	200	479	249	250	184	298	400
8	1 x 2-10	25	50	216	200	416	249	250	184	298	400
9	1.5 x 3-10	40	80	216	200	416	249	250	184	318	419
10	2 x 3-10	50	80	241	200	441	249	250	184	314	416
11	3 x 4-10	80	100	279	200	479	249	250	184	346	448
12	4 x 6-10	100	150	343	250	593	249	250	184	367	506
13	1.5 x 3-13	40	80	267	250	517	249	250	184	381	521
14	2 x 3-13	50	80	292	250	542	249	250	184	391	530
15	3 x 4-13	80	100	318	250	568	249	330	184	422	562
16	4 x 6-13	100	150	343	250	593	249	330	184	460	586

All dimensions are in millimeters.

Blackmer® Centrifugal Pumps

Frame S Pump

- Mid size frame strength and reliability in small frame space
- Heavy duty alternative to standard small frame pumps
- Lowest L3/D4 stiffness ratio of any competitive size pump 26 (1.9) Frame S
- Meets ASME/ANSI dimensional specifications
- Capacities up to 450 gpm (102 m³/hr)
- Operating temperature range from -40° to 400°F (-40° to 204°C)
- Military shock standard S901 Grade A

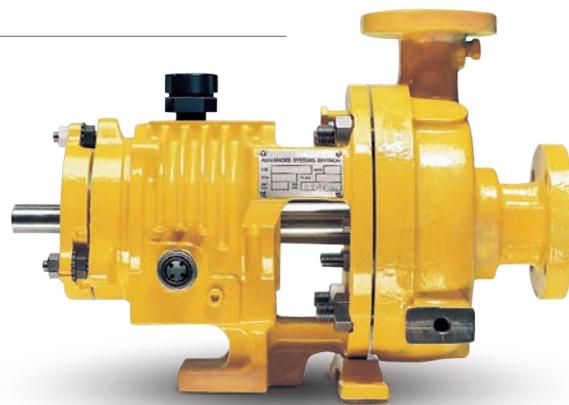

Frame S (ASME/ANSI)

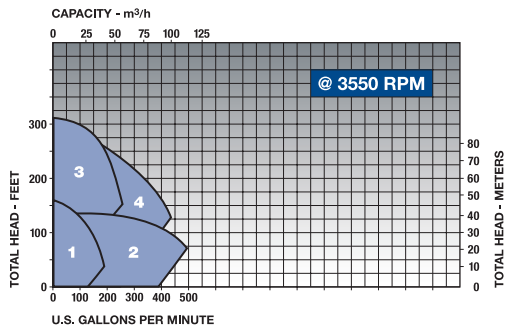
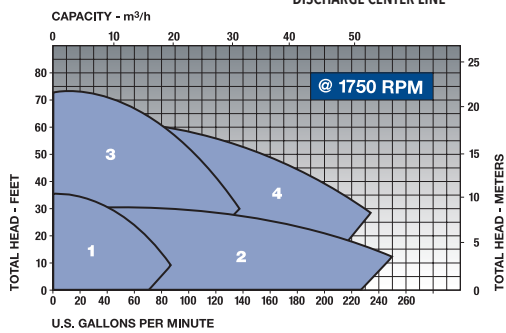
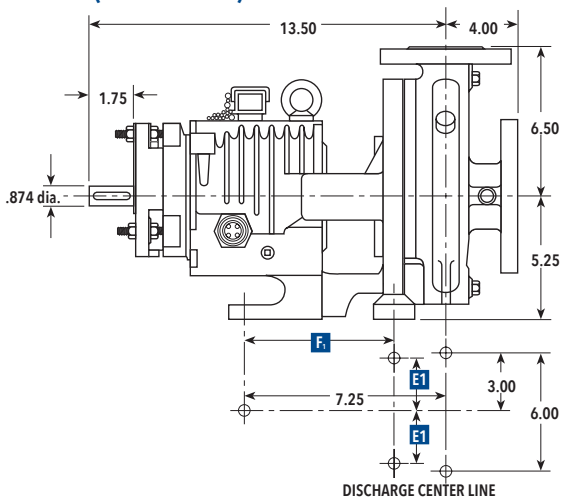

Frame S (Metric)

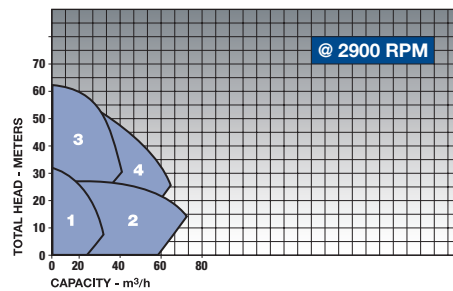
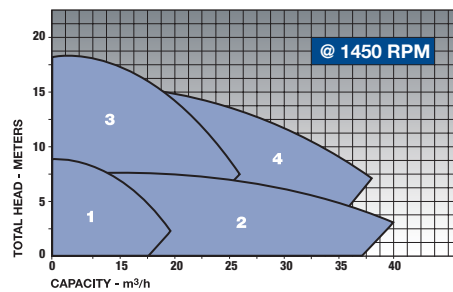
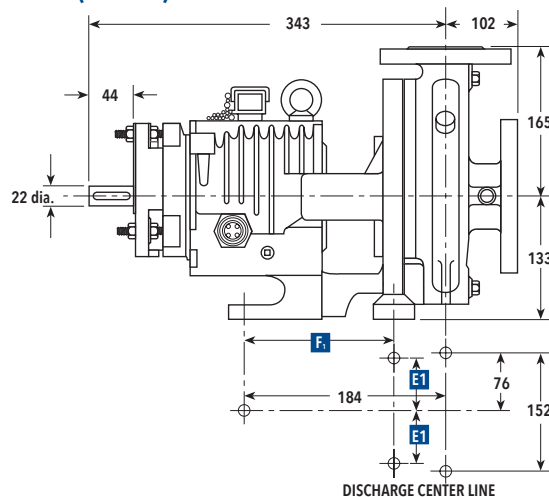

Frame S Pump – ASME/ANSI

	Pump Size	F ₁	2E ₁
1	1 x 1.5-6	4.88	5.50
2	2 x 3-6	4.88	5.50
3	1 x 1.5-8	4.25	7.50
4	1.5 x 3-8	4.25	7.50

All dimensions are in inches.

Frame S Pump – Metric

	Pump Size	F ₁	2E ₁
1	1 x 1.5-6	124	140
2	2 x 3-6	124	140
3	1 x 1.5-8	101	191
4	1.5 x 3-8	108	191

All dimensions are in millimeters.

Blackmer® Centrifugal Pumps

Frame M Pump

- Large Frame Pump
- Lowest L3/D4 stiffness ratio of any pump in this size range at 19 (.87) Frame M
- Only AMSE/ANSI B73.1 pump of its size that offers centerline mount for high temperature applications
- Capacities up to 4,500 gpm
- Operating temperature range from -40° to 400°F (-40° to 204°C)
- Military shock standard S901 Grade A
- High Temperature Series configurations available with some Frame M sizes



Frame M (ASME/ANSI)

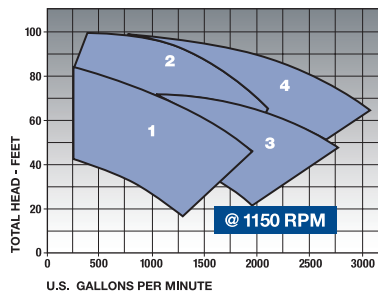
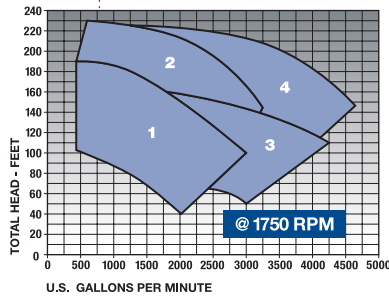
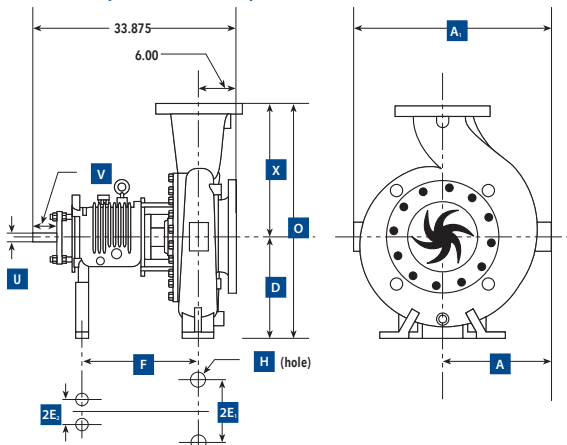

Frame M (Metric)

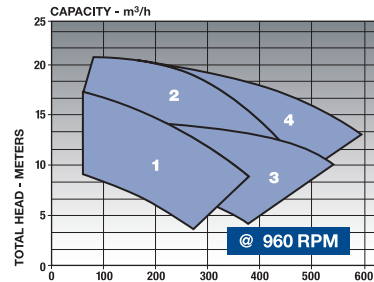
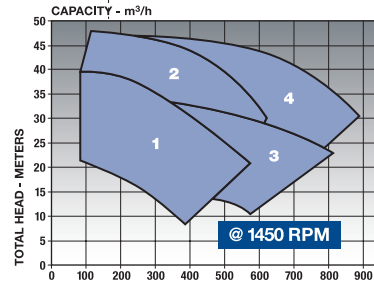
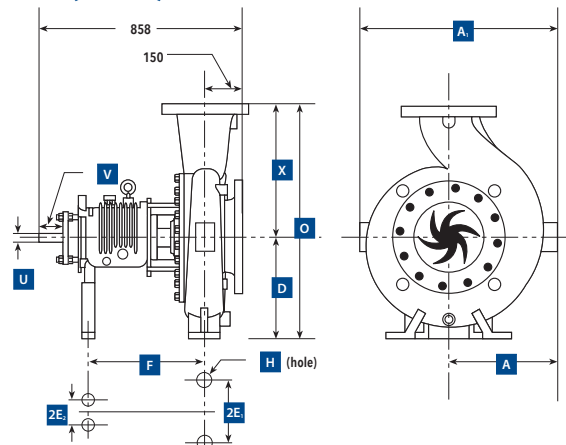

Frame M Pump – ASME/ANSI

Pump Size	A ₁	A	D	2E ₁	2E ₂	F	H	O	U	V	X	
1	6 x 8-13	25.50	14.00	14.50	16.00	9.00	18.75	0.875	30.50	2.375	4.00	16
2	6 x 8-15	27.25	14.75	14.50	16.00	9.00	18.75	0.875	32.50	2.375	4.00	18
3	8 x 10-13	27.25	15.25	14.50	16.00	9.00	18.75	0.875	32.50	2.375	4.00	18
4	8 x 10-15	28.75	15.75	14.50	16.00	9.00	18.75	0.875	33.50	2.375	4.00	19

All dimensions are in inches.

Frame M Pump – Metric

Pump Size	A ₁	A	D	2E ₁	2E ₂	F	H	O	U	V	X	
1	6 x 8-13	648	356	368	406	229	476	22	775	60	102	406
2	6 x 8-15	692	375	368	406	229	476	22	826	60	102	457
3	8 x 10-13	692	387	368	406	229	476	22	826	60	102	457
4	8 x 10-15	730	400	368	406	229	476	22	851	60	102	483

All dimensions are in millimeters.

Blackmer® Centrifugal Pumps

High Temperature Series

Available in the 450°F Line & 650°F Line

Pre-configured to meet your high temperature requirements of 450°F, 650°F and even 750°F, the Blackmer® Centrifugal High Temp Series is available for some Frame A and Frame M Centrifugal Pump models sizes.

Now able to exceed the 400°F (204°C) standard temperature limit, the Blackmer Centrifugal High Temp Series allows for maximum temperatures of up to 450°F (232°C) with **450°F Line**, 650°F (343°C) with the **650°F Line** or even up to 750°F (398°C) with a special stainless steel frame. Utilizing high temperature flanges and elastomers, along with the unique centerline mount that supports high temperatures, the Blackmer Centrifugal High Temp Series further entrenches these pumps ability to safely transfer critical and valuable fluids reliability in the harshest of service conditions.

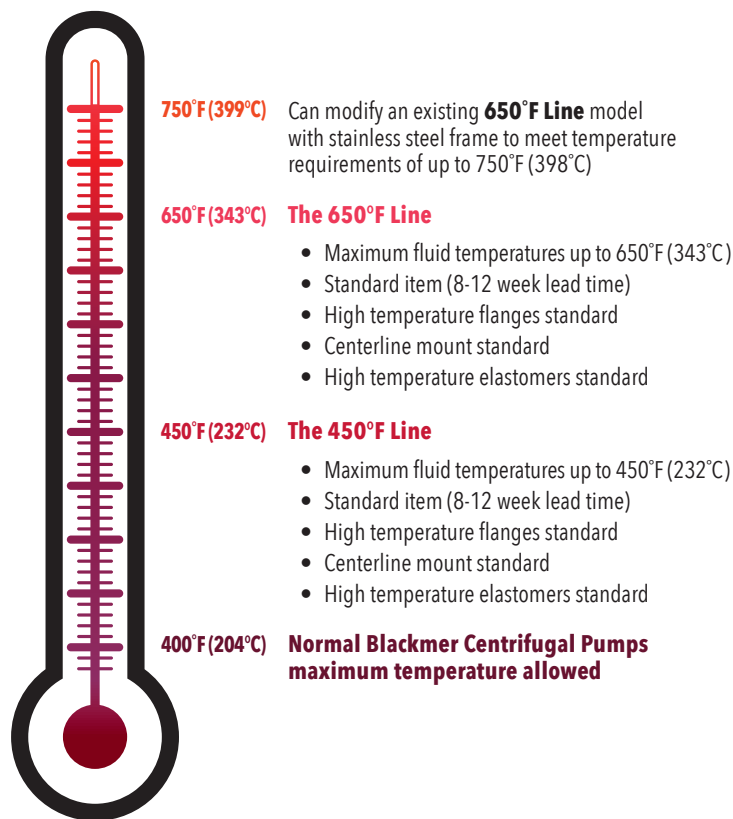
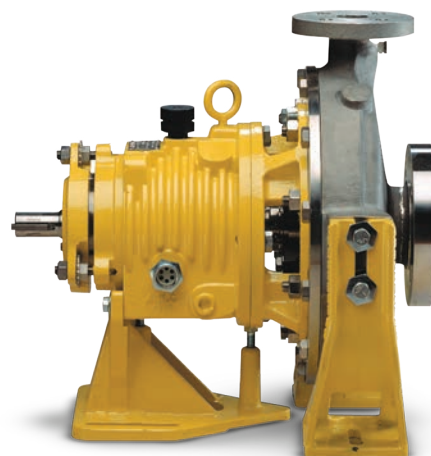

	SIZE	450°F Line	650°F Line
Frame A	2x3-8	✓	✓
	3x4-8	✓	✓
	1x2-10	✓	✓
	1.5x3-10	✓	✓
	2x3-10	✓	✓
	3x4-10	✓	✓
	4x6-10	✓	✓
	1.5x3-13L	✓	✓
	2x3-13L	✓	✓
	3x4-13L	✓	✓
Frame M	6x8-13	✓	✓
	8x10-13	✓	✓
	6x8-15	✓	✓
	8x10-15	✓	✓



PSG Grand Rapids
1809 Century Avenue SW
Grand Rapids, MI 49503-1530
USA

P: +1 (616) 241-1611

F: +1 (616) 241-3752

info@blackmer.com

blackmer.com



Where Innovation Flows

1301-007 01/22

Authorized PSG® Partner:

Copyright 2022 PSG®, a Dover company