

Significant Model Changes: LB Compressors

Date	Description	Models
Mar 2023	Rolling Bearing	LB362
Dec 2009	S3R Seal	LB602
Feb 2007	Roller Bearings & S3R Seal	LB942
Jan 1999	Flanged Heads	LB300 Series
Jan 1999	Baseplate	LB160 Series
Jan 1998	Oil Filters	All LB Compressors
Aug 1994	Crankcases	All LB Compressors
Oct. 1991	O-ring head gaskets, cartridge style packing boxes & elimination of center head bolt gaskets	LB300 & LB600 Series
Mar 1991	Packing Box Change	LB362
Feb 1991	Valve Caps	LB160 Series
Nov 1989	Crankcases And Crankshafts	LB600 Series

New Wrist Pin Bearing: LB362 (March 2023)

LB362 now has a roller bearing on the wrist pin in place of a brass bushing as standard construction.

To note this change, this model is now revision code 'D', **LB362D**

ADVANTAGES

Free of all yellow metals.

Roller bearings provide longer life under high rod load applications.

Adequate wrist pin lubrication is assured under all load conditions.

PARTS INTERCHANGEABILITY CONSIDERATIONS

In addition to the roller bearings, these units now have a 1" wrist pin in place of the 7/8" wrist pin used previously. Upgrading a previous model will require replacing the connecting rod assemblies, wrist pins, wrist pin plugs, and X-Head/Piston Rod Assemblies. All parts for previous models will continue to be available except the crosshead assembly part number 793429.

S3R SEAL: LB602 (Dec 2009)

The LB602 compressor now have a new oil control seal (S3R) incorporated into the lower packing box. These changes are now standard construction. Parts lists and IOM's are available from the Blackmer website.

The current model number is now LB602C, replacing the previous version (LB602B).

Advantages of upgrades

- Enhanced oil control with the addition of the S3R seal

Parts Interchangeability Considerations

The previous LB602B compressors can use the new S3R seal by replacing the Packing Box assemblies. Previous design packing boxes will continue to be available as repair parts.

ROLLER BEARINGS & S3R SEAL: LB942 (Feb 2007)

Effective immediately, all Blackmer LB900 series compressors now have a split roller bearing on the wrist pin in place of a brass bushing. In addition, a new oil control seal (S3R) has been incorporated into the lower packing box. These changes are now standard construction. Parts lists and IOM's are available from the Blackmer website.

The current model number is now LB942B, replacing the previous version (LB942A).

Advantages of upgrades

- These models are now free of all yellow metals
- Roller bearings provide longer life under high rod load applications
- Superior wrist pin lubrication is assured under all load conditions
- Enhanced oil control with the addition of the S3R seal

Parts Interchangeability Considerations

The previous LB942A compressors can use the new roller bearing and S3R seal by replacing the Connecting Rod Assemblies and Packing Boxes. The S3R seal **must** be installed if converting to the roller bearing design. A roller bearing may not be installed in place of a bushing; the entire connecting rod **must** be replaced. No other changes are needed. Connecting rod assemblies with bronze bushings and previous design packing boxes will continue to be available as repair parts.

New Flanged Heads: LB361B and LB362C (Jan 1999)

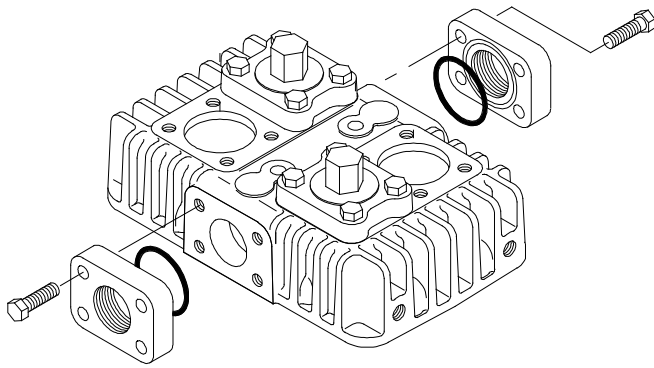

Flanged head

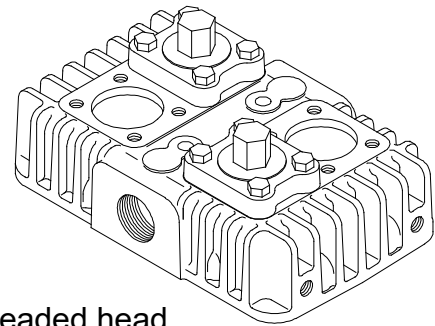

Threaded head
previously used

150-1002x2

The cylinder head used on the LB361B and the LB362C is being changed from a threaded design to a flanged design. Flanges are available in various sizes in both standard NPT and optional weld types. The use of flanges offers much greater flexibility in meeting the various piping connections requested by our customers.

The model numbers remain LB361B and LB362C.

Although the head is seldom ordered as a repair part, only the flanged style will be available. The new design flanged head will bolt into the place of the old design threaded head, although some small changes to the piping will be needed to accommodate the flanges.

This change will take place about Jan. 1999.

New Baseplate For All 160 and 170 Series Compressors (Jan 1999)

The baseplate used on all 160 and 170 series compressors is being lengthened from 42" (107 cm) to 44" (112 cm). The extra 2" is being added at the motor end to better accommodate the mounting of the motor slide base.

No part numbers will change as the 42" version will no longer be available except as a special order part. This change will take place in January 1999.

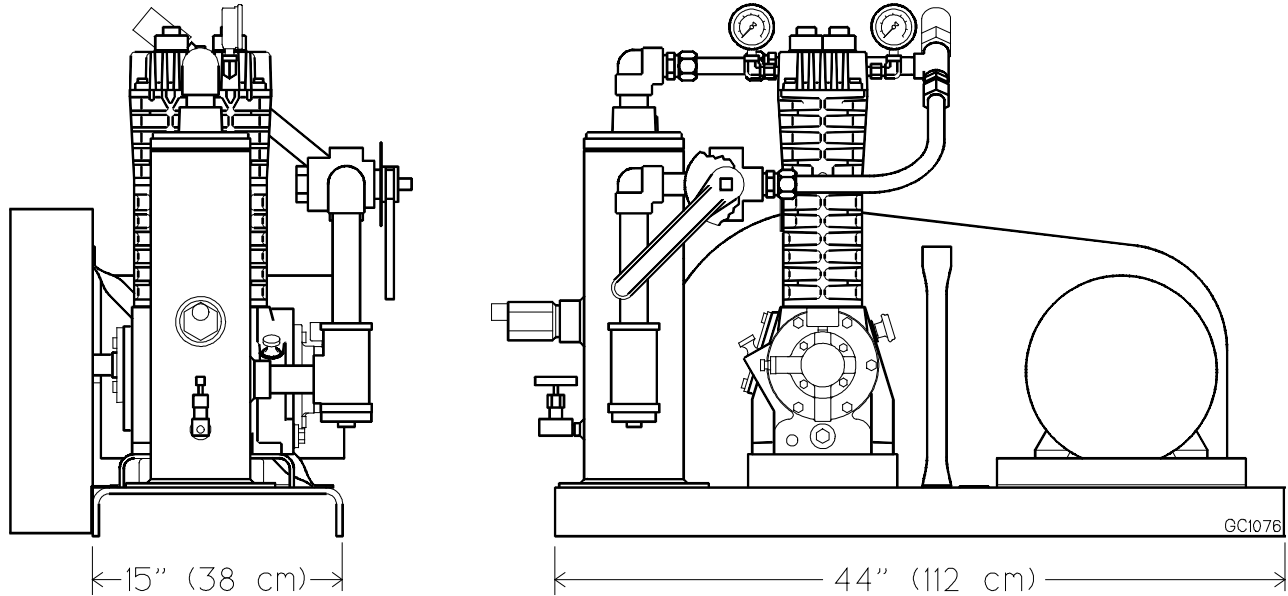

'LB' COMPRESSOR OIL FILTERS (Jan 1998)

All Blackmer 'LB' compressors are now fitted with an external automotive type spin-on oil filter as standard equipment. The filter provides extended protection in severe duty service and will normally double the time between oil changes.

The 10th position of the 11 character ID number shown on the compressor nameplate indicates whether an external oil filter is installed. Code 'C' is now standard on all 'LB' compressors.

Code	Description
A	Standard Crankshaft (no Oil Filter)
B	Extended Crankshaft (no Oil Filter)
C	Standard Crankshaft with Oil Filter
D	Extended Crankshaft with Oil Filter

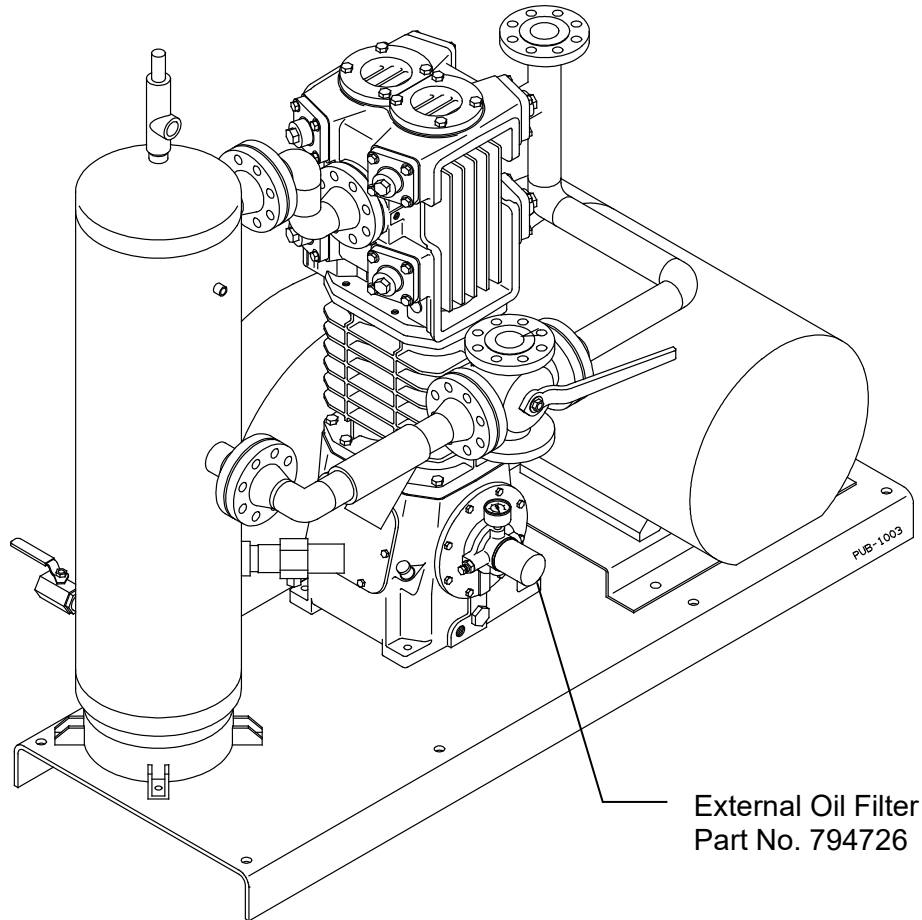

NEW CRANKCASES for 'LB' SERIES COMPRESSORS (Aug. 1994)

All Blackmer 'LB' series compressors are now (Aug. 94) being fitted with a new style crankcase. New model numbers will be as shown in the following table:

	MODELS		
Single-Seal	LB161B	LB361B	LB601B
Double-Seal	LB162B	LB362C	LB602B

The new crankcases offer a number of benefits:

- **Self reversing oil pump** with optional external filter.
- Oil pump drive design eliminates the bronze oil pump bushing.
- Larger main bearings for longer life.
- Common bearings, oil pump, and other parts mean more complete interchangeability and fewer parts to stock.

Mounted units (B, TU, TC, LU and LC) will have the same dimensions as previous versions. If a new LB160 or LB360 series compressor is to be mounted in place of an existing unit, no changes to the baseplate or piping should be required. Replacing an LB600 series compressor will require redrilling the baseplate holes as the compressor footprint is larger, but no piping changes should be required.

All Models: Top end wear parts such as valves, piston rings, seals and gasket sets are completely interchangeable between older and newer styles. Individual crankcase parts are **not** interchangeable. An entire new style crankcase assembly may be fitted to an older machine.

LB161, LB361A, LB362B: Parts such as crosshead/piston rod assemblies, cylinders, pistons, guides, packing boxes, connecting rods, wrist pin bushings, rod bearings, etc. are also fully interchangeable with the new models.

LB162: The crosshead/piston rod assemblies, connecting rods, wrist pin bushings, and rod bearings, are fully interchangeable with the new models. Cylinders, packing boxes, guides, and distance pieces are **not** interchangeable.

LB601A, LB602A: The crosshead/piston rod assemblies, cylinders, pistons, connecting rods, wrist pin bushings, rod bearings, etc. are **not** interchangeable with the new models.

Most parts for the previous versions will continue to be offered.

ANCHOR BOLT LOCATIONS
 600A VS 600B SERIES
 COMPRESSORS

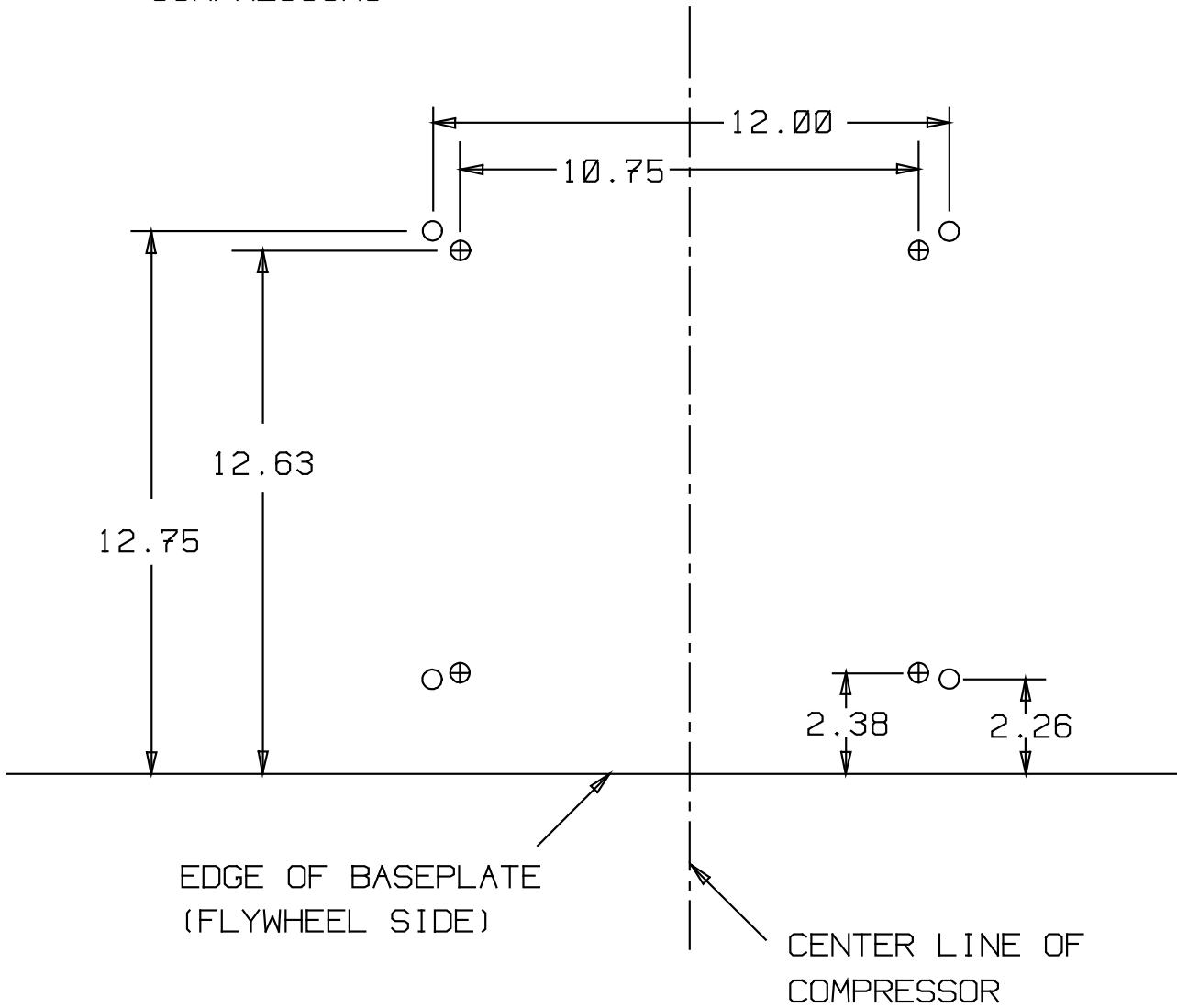

- ⊕ 600A SERIES
- 600B SERIES

MODEL CHANGES: LB361A, LB362B, LB601A, LB602A (Oct. 1991)

O-ring head gaskets, cartridge style 2-seal packing boxes & elimination of center head bolt gaskets

Beginning with Serial Number 102391-L (Oct. 91) all of these models will be built with a number of improved features designed to eliminate possible leakage paths and ensure leak-free operation under all conditions. The heads and cylinders have been redesigned to replace the flat gasket between them with an O-ring and to eliminate the center head bolt gaskets. In addition, the LB601A and LB602A flanges use O-rings instead of flat gaskets.

The double seal models (LB362B and LB602A) now feature a single cartridge on each rod that contains both seals. This design is simpler, easier to assemble, and ensures proper alignment for more even packing wear and longer packing life.

Model:	LB361A	LB362B	LB601A	LB602A
Main Bearings	Same	Same	Same	Same
Journal Bearings				
Wrist Pin & Bushing				
Crosshead				
Valves				
Piston Rings & Expanders				
Packing	Same	New	Same	New
Gasket Sets	Same ¹	New	Same ¹	New

Typical wear parts are much the same as before, particularly for the standard LP-Gas and NH₃ compressors (LB361 & LB601).

¹ The standard gasket sets (Buna-N, Aluminum) include both the older flat head gasket and the O-rings used on the newer styles. Gaskets sets with Iron, PTFE, or FKM have a different number for the newer units.

Most major castings such as Crosshead Guides, Distance Pieces, Cylinders, and Heads are available for the older styles in limited quantities. Here is a chart outlining those major parts that will need to be replaced if an older style unit is to be upgraded to the current construction. Please note that if any one of these components is to be upgraded on an older machine, all must be upgraded.

Old Model #	Crosshead Guide & Packing Cartridges	Head & Cylinder
LB361*	Reuse	New
LB362	New	New
LB362A	Reuse	New
LB601	Reuse	New
LB602	New	New

* The 793101 LB361 cylinder is no longer available. Please substitute the following parts: 793045 cylinder, 793044 head, 793055 (qty 2) flanges, 794096 (qty 8) flange bolts, 793099 gasket set.



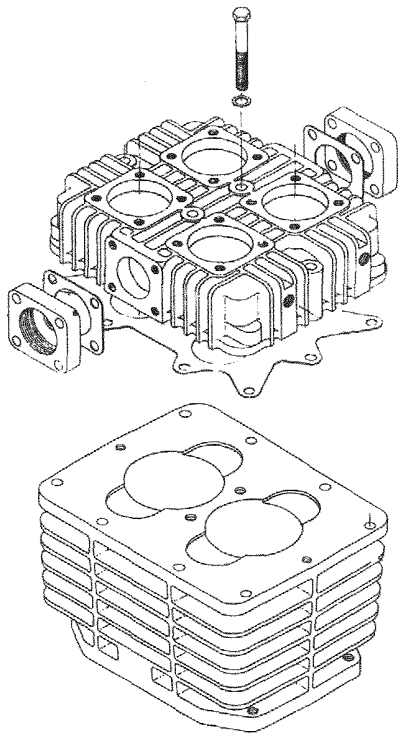

**Typical Older Version with
Flat Gaskets and
Center Head Bolt Gasket**

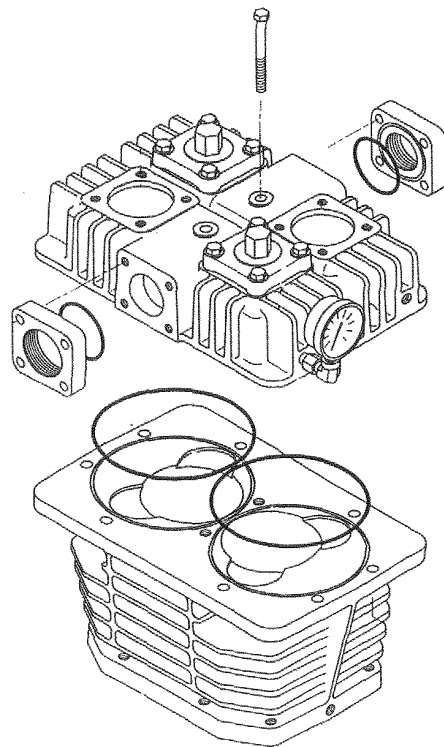

**New Version with
O-rings and
No Center Head Bolt Gaskets**

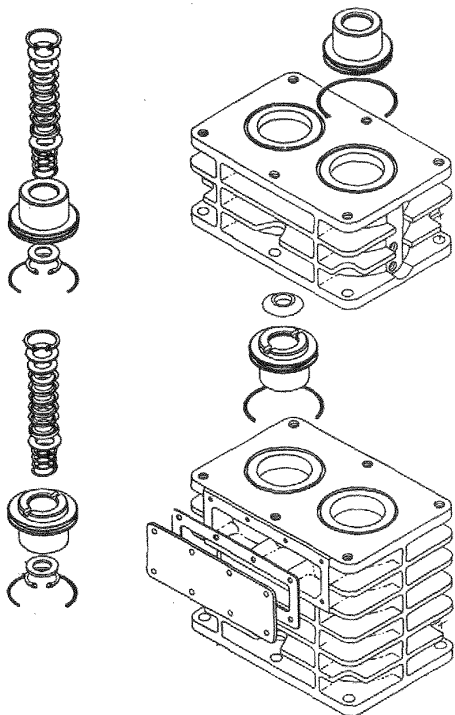

**Typical Older Version with
Separate Packing Boxes**

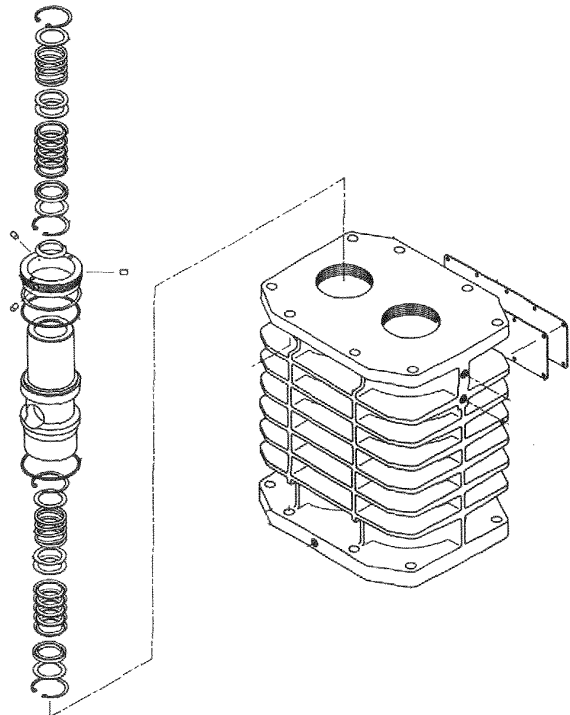

**New Version with
Single Packing Cartridge**

LB362 PACKING BOX CHANGE (March 1991)

Beginning with Serial Number 032072-L (built March 1991 and later) all model LB362 compressors use a new packing cartridge that contains both upper and lower sets of packing. The single cartridge design provides better alignment of the packing and the piston rod resulting in more even packing wear and longer packing life. Maintenance will be simpler since both sets of packing are removed at once with the packing cartridge. There are now several fewer parts so assembly and disassembly are easier. The change is based on a crosshead guide that has been extended to include the distance piece, thus combining two parts into one. The change also involves a different compressor cylinder. The LB361 and LB362 now use the same cylinder.

Major parts such as crosshead guides, distance pieces and cylinders for old style compressors will be available in limited quantities. Parts that are more likely to need replacement such as packing sets and packing boxes will be readily available. The cylinder, packing cartridges, and crosshead guide will all have to be replaced as a group to convert an older LB362 to the new style.

The packing set part number has been changed to 793499. Some of the washers used are different but the packing itself is the same. The new packing set can be used in old style compressors by reusing the old washers. The new packing cartridge takes different O-rings than the old packing boxes. These new O-rings were added to the LB362 gasket set so it can be used in either type compressor.

Like the old style, the new version has provisions to vent, purge, or drain the distance piece. The LB362 still has no rod overtravel from one packing set to the other. This prevents oil contamination of the process gas stream.

With this change, the proper model number becomes LB362A.

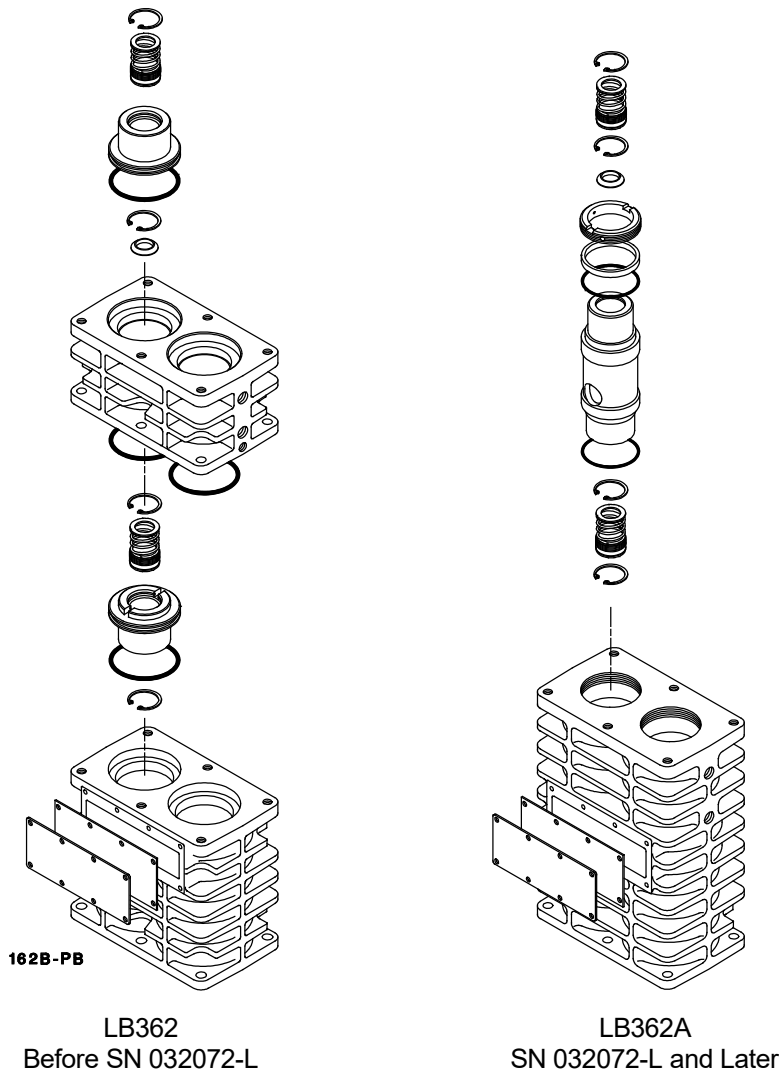

NEW VALVE CAPS FOR LB161 AND LB162 COMPRESSORS (Feb 1991)

Blackmer Model LB161 and LB162 compressors are now being built with a new style valve cap. The new cap uses an O-ring rather than a metal gasket. The O-ring provides superior sealing compared to the metal gasket.

This change took place in January, 1991 with serial number 011987-L.

Since the two valve caps are completely interchangeable, the old cap is no longer available. The metal gaskets will still be available for parts orders. Gasket sets will contain both the metal gaskets and the O-rings. All other parts remain unchanged.

PART NUMBERS INVOLVED:

OLD VALVE CAP	792001	NEW VALVE CAP	792003
METAL GASKET (ALUM.)	792108	O-RING (BUNA-N)	792306
METAL GASKET (IRON)	792202	O-RING (PTFE)	792307
		O-RING (FKM)	792308

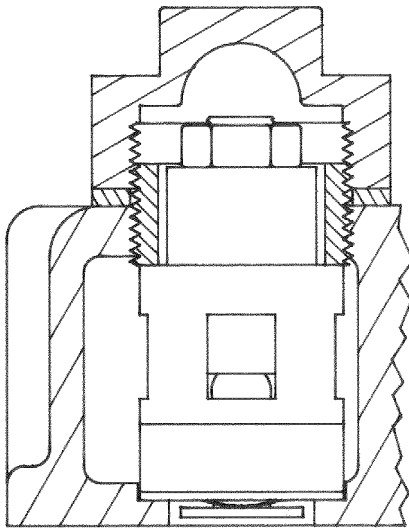

792001
(With Gasket)

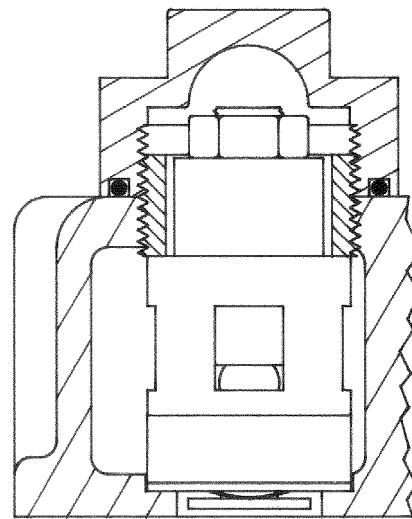

792003
(With O-Ring)

LB601 AND LB602 CRANKCASES AND CRANKSHAFTS (Nov 1989)

Beginning with serial number 111751-J (Nov. 1989), all LB601 and LB602 compressors were shipped with different crankcases and crankshafts. The major change was made to the crankshaft. The change consisted of removing the center counterweight and making the two end counterweights larger. The crankcase was changed to accept the larger counterweights. Specifically, the bearing carrier opening was modified and there were some other internal changes for clearance purposes. All other parts including the connecting rods, bearing carrier, bearings, etc remain unchanged.

Compressors with the old style crankcase **must** use the old style crankshaft as there will not be adequate clearance for the new style shaft. Compressors with the new style crankcase can use either crankshaft. To eliminate the possibility of someone getting the wrong crankshaft, only the previous style will be used for parts shipments.

Part numbers involved:

794159 standard length

794209 extended length

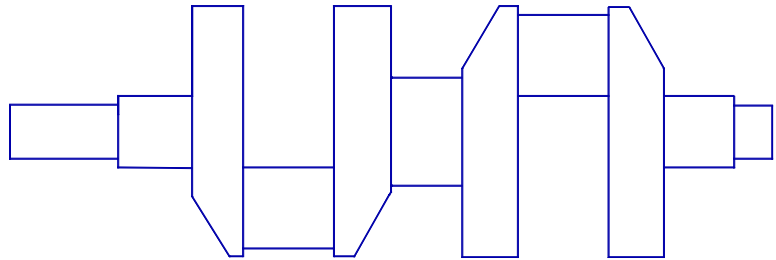

OLD STYLE

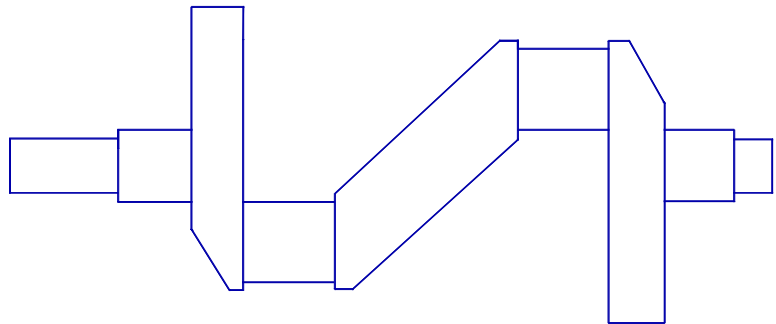

NEW STYLE