

TYPE	SIZE	UNIT STYLE
X	2.5B	PO

**DIMENSIONS 101-110**

Section	101
Effective	Sep 2023
Replaces	Feb 2003
Page	1/8

RIGHT HAND ROTATION. FOR LEFT HAND ROTATION, SHAFT PROJECTION IS OPPOSITE THAT SHOWN.

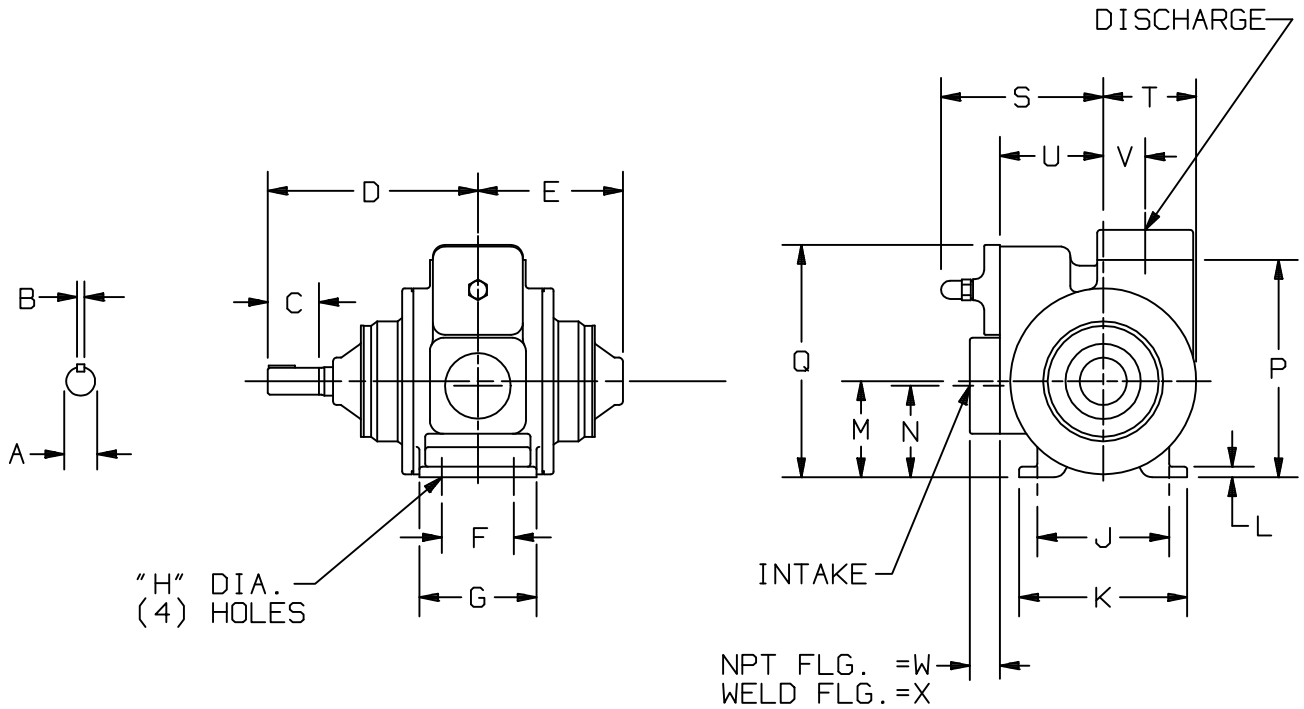

MOTOR			UNITS	DIMENSIONS									
FRAME SIZE				A	B	C	D	E	F	G	H	J	K
			IN	1 1/8	1/4	2 1/4	8 3/4	6	3	4 7/8	7/16	5 1/2	7
			MM	28,6	6,4	57,2	222,3	152,4	76,2	123,8	11,1	139,7	177,8
				L	M	N	P	Q	R	S	T	U	V
			IN	7/16	4	3 3/4	9 1/16	9 5/8	—	6 13/16	3 7/8	4 5/16	1 3/4
			MM	11,1	101,6	95,3	230,2	244,5	—	173	98,4	109,5	44,4
				W	X	Y	Z	AA	BB	CC	DD	EE	FF
			IN	1 3/16	1 1/4	—	—	—	—	—	—	—	—
			MM	30,2	31,8	—	—	—	—	—	—	—	—
				GG	HH					PUMP WEIGHT	WITH STD. FLANGES		
			IN	—	—					LBS	93		
			MM	—	—					KG	42		



TYPE	SIZE	UNIT STYLE
X	2.5B	HROF

DIMENSIONS 101-110	
Section	101
Effective	Sep 2023
Replaces	Feb 2003
Page	3/8

RIGHT HAND ROTATION

(4)  $\varnothing \frac{5}{8}$  ANCHOR HOLES

DISCHARGE SPECIAL BLACKMER FLANGE REQ'D

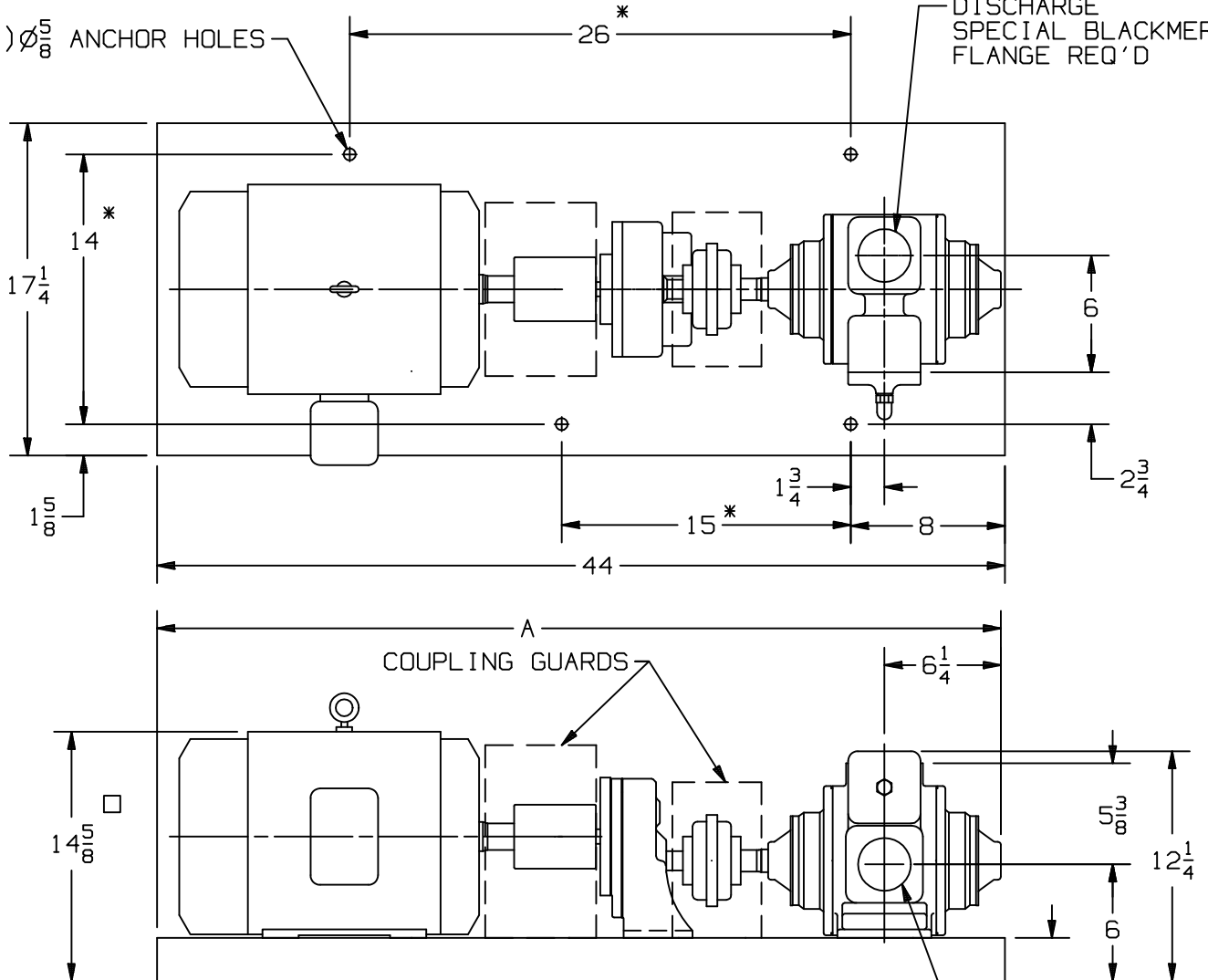

UNIT DIMENSION LESS FLANGES

\* TOLERANCE  $\pm \frac{1}{8}$

TOLERANCE ON OTHER DIMENSIONS  $\pm \frac{1}{4}$

□ DIMENSION LESS EYEBOLT

INTAKE SPECIAL BLACKMER FLANGE REQ'D

FLG HGT: 2 1/2" NPT - 1 3/16  
2 1/2" WELD - 1 1/4

MOTOR			BASE NO.	DIMENSIONS	
FRAME SIZE		UNITS		A	
213T		901579	IN	44 3/4	
			MM	1136.7	
215T		901579	IN	44 3/4	
			MM	1136.7	

DIMENSIONS 101-110

Section 101  
 Effective Sep 2023  
 Replaces Feb 2003  
 Page 4/8

TYPE

SIZE

UNIT  
 STYLE

X

2.5B

HROF



www.blackmer.com

LEFT HAND ROTATION

(4)  $\varnothing \frac{5}{8}$  ANCHOR HOLES

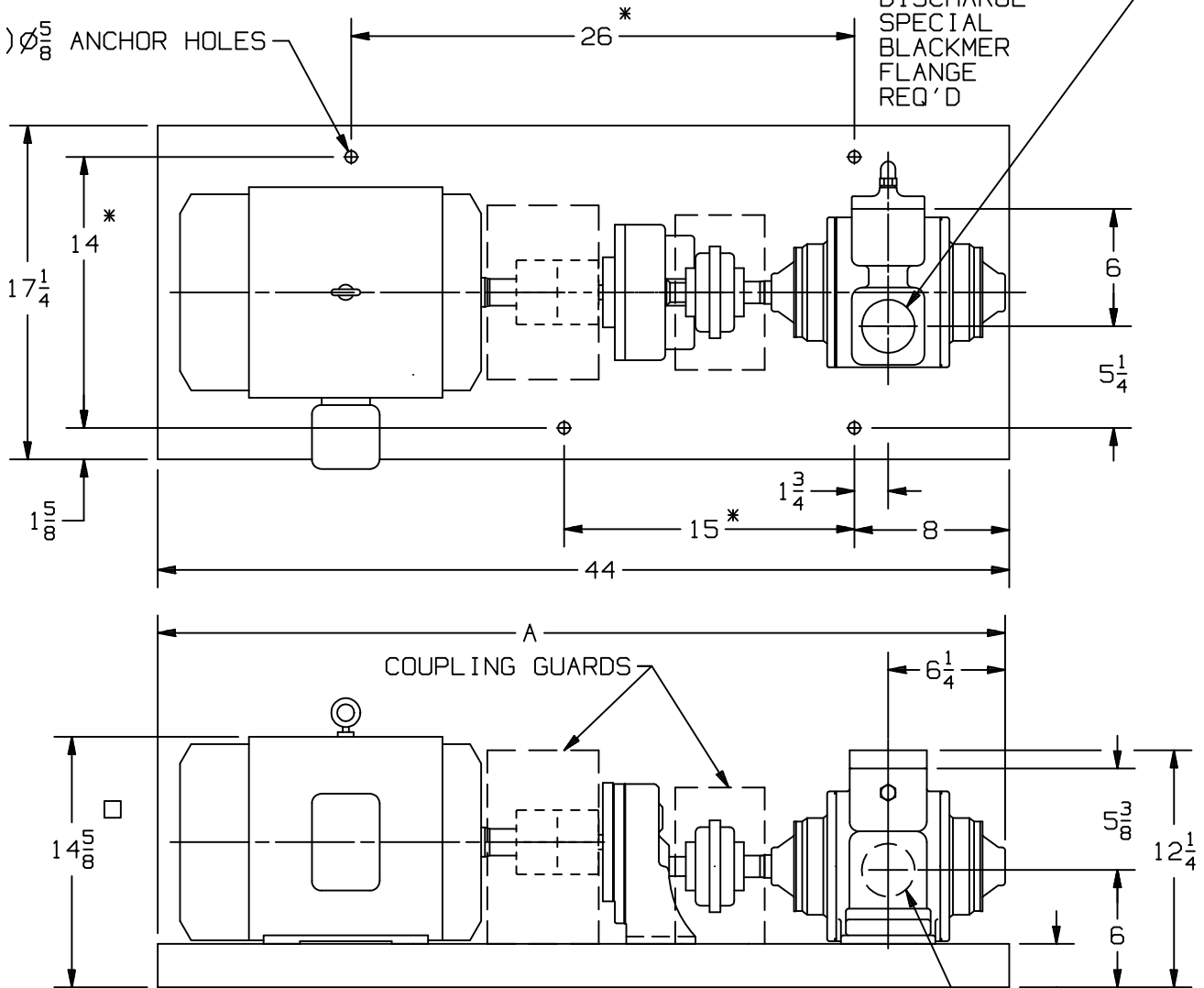

UNIT DIMENSION LESS FLANGES

\* TOLERANCE  $\pm \frac{1}{8}$

TOLERANCE ON OTHER DIMENSIONS  $\pm \frac{1}{4}$

□ DIMENSION LESS EYEBOLT

INTAKE SPECIAL BLACKMER FLANGE REQ'D

FLG HGT: 2 1/2" NPT - 1 3/16  
 2 1/2" WELD - 1 1/4

MOTOR			BASE NO.	DIMENSIONS	
FRAME SIZE				UNITS	A
213T			901579	IN	44 3/4
				MM	1136.7
215T			901579	IN	44 3/4
				MM	1136.7

TYPE	SIZE	UNIT STYLE
X	2.5B	HRA

DIMENSIONS 101-110	
Section	101
Effective	Sep 2023
Replaces	Feb 2003
Page	5/8

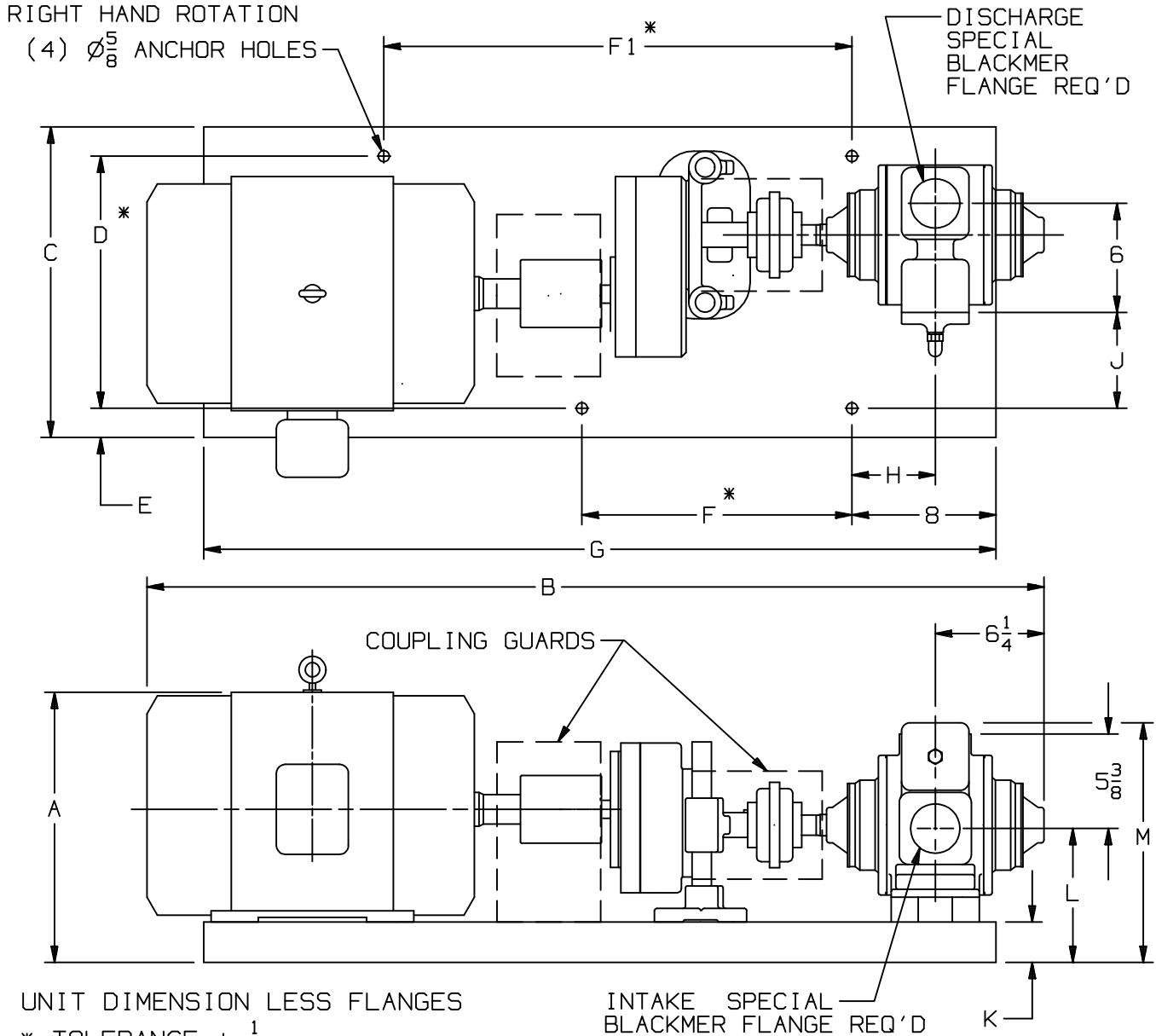

UNIT DIMENSION LESS FLANGES

\* TOLERANCE  $\pm \frac{1}{8}$

TOLERANCE ON OTHER DIMENSIONS  $\pm \frac{1}{4}$

"A" DIMENSION LESS EYEBOLT

FLG HGT: 2 1/2" NPT - 1 3/16  
2 1/2" WELD - 1 1/4

MOTOR			UNITS	DIMENSIONS												
FRAME SIZE				A	B	C	D	E	F	F1	G	H	J	K	L	M
182T			901774	11 5/8	47 3/8	17 1/4	14	1 5/8	15	26	44	4 5/8	5 3/8	2 1/4	7 3/8	13 5/8
184T			901774	11 5/8	47 3/8	17 1/4	14	1 5/8	15	26	44	4 5/8	5 3/8	2 1/4	7 3/8	13 5/8
213T			901774	13 3/8	47 5/8	17 1/4	14	1 5/8	15	26	44	4 5/8	5 3/8	2 1/4	7 3/8	13 5/8
215T			901774	13 3/8	48 1/4	17 1/4	14	1 5/8	15	26	44	4 5/8	5 3/8	2 1/4	7 3/8	13 5/8
254T			901774	15 5/8	52 1/8	17 1/4	14	1 5/8	15	26	44	4 5/8	5 3/8	2 1/4	7 3/8	13 5/8
256T			901774	15 5/8	53 7/8	17 1/4	14	1 5/8	15	26	44	4 5/8	5 3/8	2 1/4	7 3/8	13 5/8
284T			901578	18	55 3/4	20 3/4	16 3/8	2	22	33	50 1/2	1 3/4	7 1/8	3	7 3/4	14

DIMENSIONS 101-110		TYPE	SIZE	UNIT STYLE	 <a href="http://www.blackmer.com">www.blackmer.com</a>
Section Effective Replaces Page	101 Sep 2023 Feb 2003 6/8	X	2.5B	HRA	

LEFT HAND ROTATION

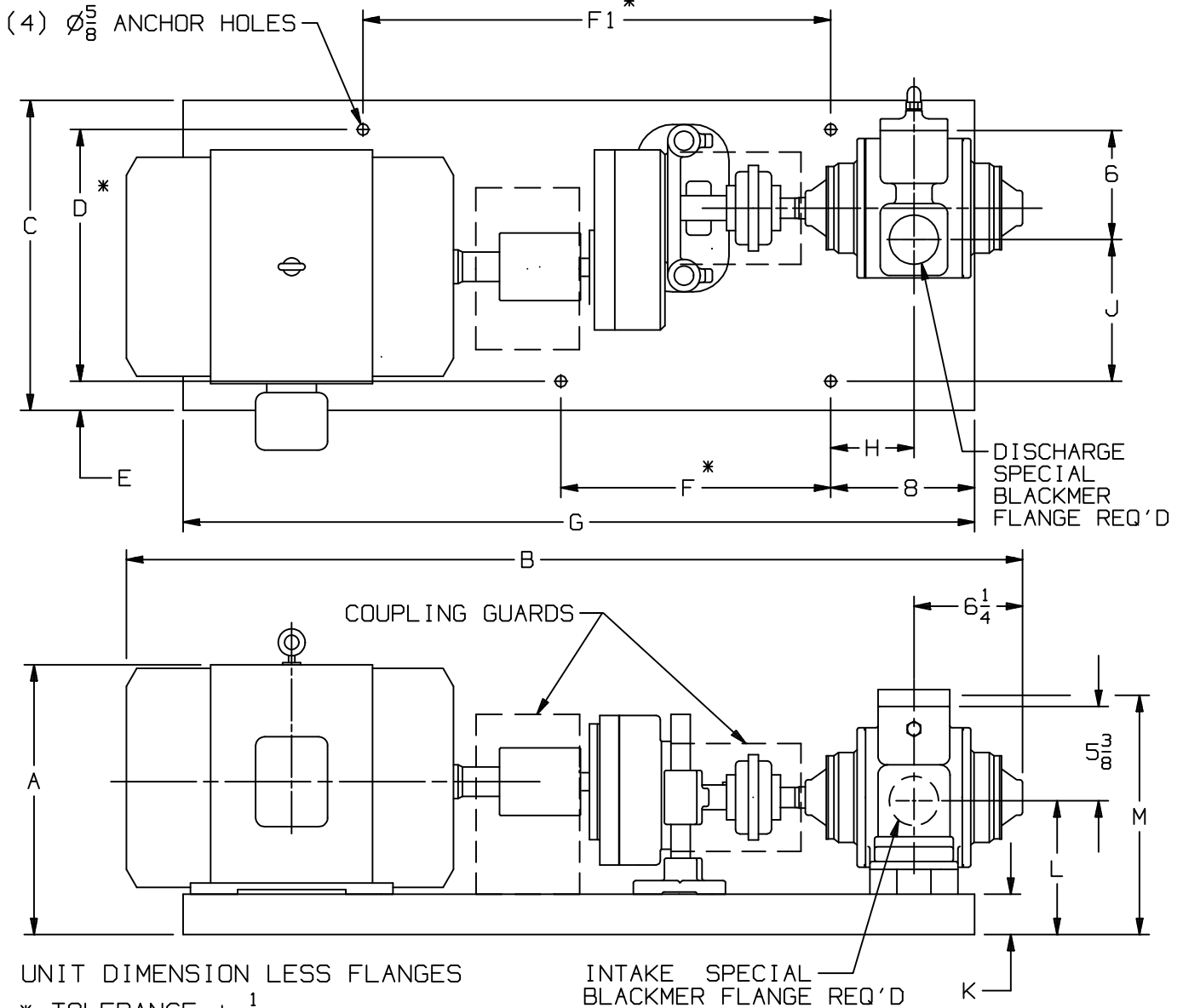

UNIT DIMENSION LESS FLANGES

\* TOLERANCE  $\pm \frac{1}{8}$

TOLERANCE ON OTHER DIMENSIONS  $\pm \frac{1}{4}$

"A" DIMENSION LESS EYEBOLT

INTAKE SPECIAL BLACKMER FLANGE REQ'D

FLG HGT: 2 1/2" NPT - 1 3/16  
2 1/2" WELD - 1 1/4

MOTOR		UNITS	DIMENSIONS													
FRAME SIZE			A	B	C	D	E	F	F1	G	H	J	K	L	M	
182T		901774	11 5/8	47 3/8	17 1/4	14	1 5/8	15	26	44	4 5/8	7 7/8	2 1/4	7 3/8	13 5/8	
184T		901774	11 5/8	47 3/8	17 1/4	14	1 5/8	15	26	44	4 5/8	7 7/8	2 1/4	7 3/8	13 5/8	
213T		901774	13 3/8	47 5/8	17 1/4	14	1 5/8	15	26	44	4 5/8	7 7/8	2 1/4	7 3/8	13 5/8	
215T		901774	13 3/8	48 1/4	17 1/4	14	1 5/8	15	26	44	4 5/8	7 7/8	2 1/4	7 3/8	13 5/8	
254T		901774	15 5/8	52 1/8	17 1/4	14	1 5/8	15	26	44	4 5/8	7 7/8	2 1/4	7 3/8	13 5/8	
256T		901774	15 5/8	53 7/8	17 1/4	14	1 5/8	15	26	44	4 5/8	7 7/8	2 1/4	7 3/8	13 5/8	
284T		901578	18	55 3/4	20 3/4	16 3/8	2	22	33	50 1/2	1 3/4	9 5/8	3	7 3/4	14	

TYPE	SIZE	UNIT STYLE
X	2.5B	HRB

DIMENSIONS 101-110	
Section	101
Effective	Sep 2023
Replaces	Feb 2003
Page	7/8

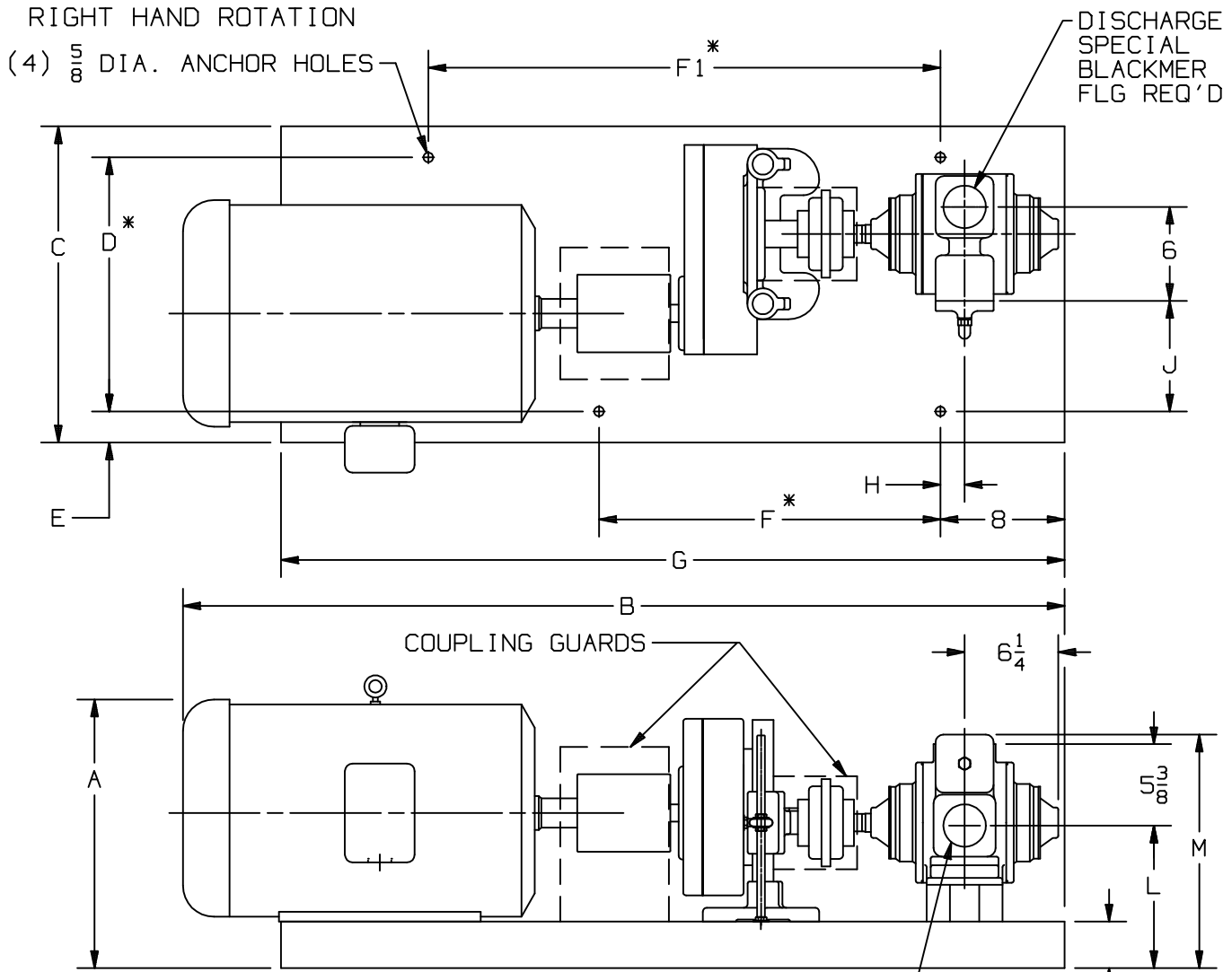

UNIT DIMENSION LESS FLANGES  
\* TOLERANCE  $\pm\frac{1}{8}$   
TOLERANCE ON OTHER DIMENSIONS  $\pm\frac{1}{4}$   
"A" DIMENSION LESS EYEBOLT

FLG. HGT: 2 1/2" NPT - 1 3/16  
2 1/2" WELD - 1 1/4

FRAME SIZE	MOTOR	BASE NO.	DIMENSIONS												
			A	B	C	D	E	F	F1	G	H	J	K	L	M
182T		901772	12 7/8	45 1/4	17 1/4	14	1 5/8	15	26	44	1 1/2	5 3/8	2 1/4	8 3/8	14 5/8
184T		901772	12 7/8	46 5/8	17 1/4	14	1 5/8	15	26	44	1 1/2	5 3/8	2 1/4	8 3/8	14 5/8
213T		901772	13 5/8	48 5/8	17 1/4	14	1 5/8	15	26	44	1 1/2	5 3/8	2 1/4	8 3/8	14 5/8
215T		901772	13 5/8	49 3/8	17 1/4	14	1 5/8	15	26	44	1 1/2	5 3/8	2 1/4	8 3/8	14 5/8
254T		901773	16 3/8	53 1/8	20 3/8	16 3/8	2	22	33	50 1/2	1 5/8	7 1/4	3	9 1/8	15 3/8
256T		901773	16 3/8	54 7/8	20 3/8	16 3/8	2	22	33	50 1/2	1 5/8	7 1/4	3	9 1/8	15 3/8
284T		901773	18	56 7/8	20 3/8	16 3/8	2	22	33	50 1/2	1 5/8	7 1/4	3	9 1/8	15 3/8
286T		901773	18	58 3/8	20 3/8	16 3/8	2	22	33	50 1/2	1 5/8	7 1/4	3	9 1/8	15 3/8

DIMENSIONS 101-110

Section 101  
 Effective Sep 2023  
 Replaces Feb 2003  
 Page 8/8

TYPE	SIZE	UNIT STYLE
X	2.5B	HRB



LEFT HAND ROTATION

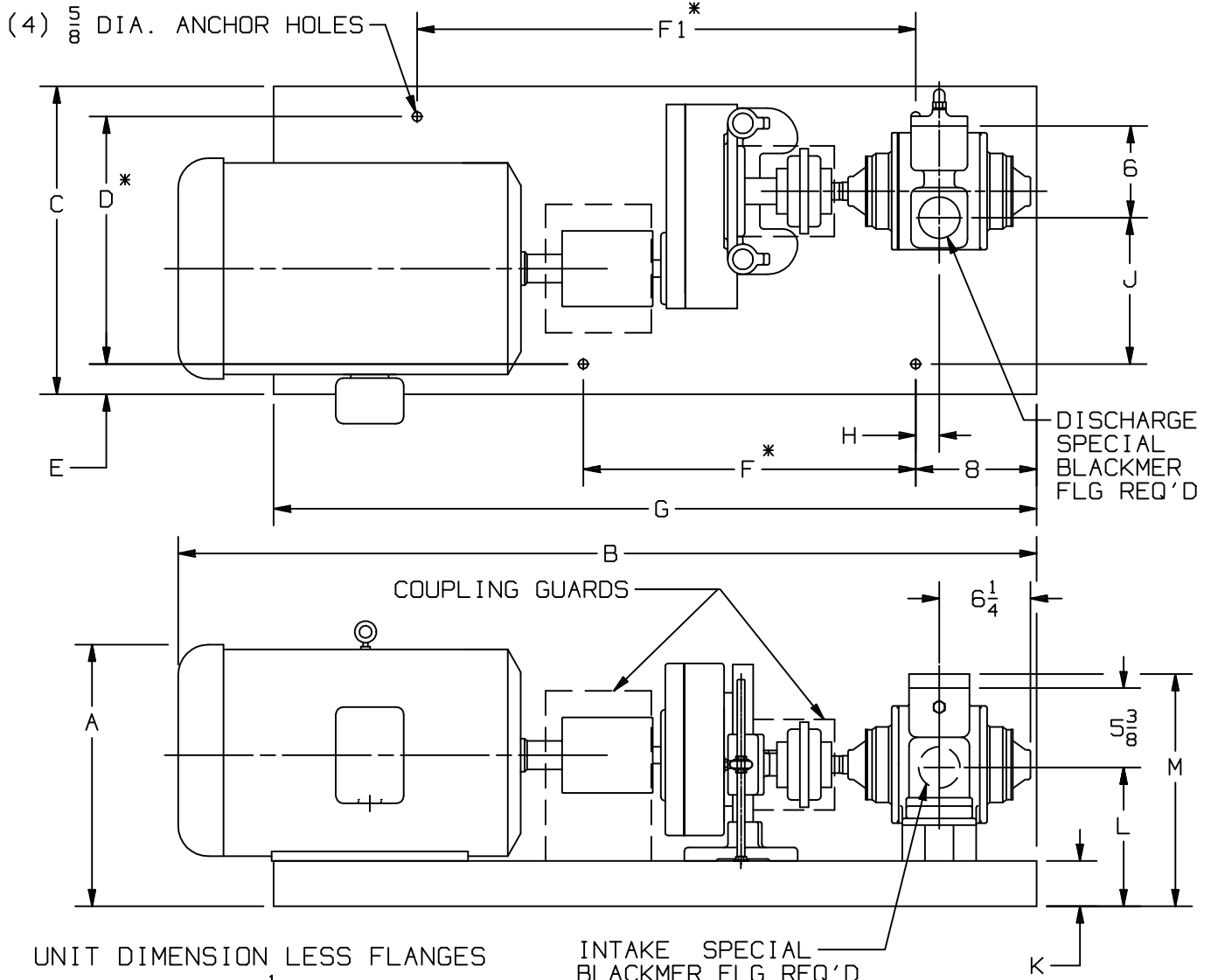

UNIT DIMENSION LESS FLANGES

\* TOLERANCE  $\pm \frac{1}{8}$

TOLERANCE ON OTHER DIMENSIONS  $\pm \frac{1}{4}$

"A" DIMENSION LESS EYEBOLT

FLG. HGT: 2 1/2" NPT - 1 3/16  
 2 1/2" WELD - 1 1/4

FRAME SIZE	MOTOR		BASE NO.	DIMENSIONS												
				A	B	C	D	E	F	F1	G	H	J	K	L	M
182T			901772	12 7/8	45 1/4	17 1/4	14	1 5/8	15	26	44	1 1/2	7 7/8	2 1/4	8 3/8	14 5/8
184T			901772	12 7/8	46 5/8	17 1/4	14	1 5/8	15	26	44	1 1/2	7 7/8	2 1/4	8 3/8	14 5/8
213T			901772	13 5/8	48 5/8	17 1/4	14	1 5/8	15	26	44	1 1/2	7 7/8	2 1/4	8 3/8	14 5/8
215T			901772	13 5/8	49 3/8	17 1/4	14	1 5/8	15	26	44	1 1/2	7 7/8	2 1/4	8 3/8	14 5/8
254T			901773	16 3/8	53 1/8	20 3/8	16 3/8	2	22	33	50 1/2	1 5/8	9 3/4	3	9 1/8	15 3/8
256T			901773	16 3/8	54 7/8	20 3/8	16 3/8	2	22	33	50 1/2	1 5/8	9 3/4	3	9 1/8	15 3/8
284T			901773	18	56 7/8	20 3/8	16 3/8	2	22	33	50 1/2	1 5/8	9 3/4	3	9 1/8	15 3/8
286T			901773	18	58 3/8	20 3/8	16 3/8	2	22	33	50 1/2	1 5/8	9 3/4	3	9 1/8	15 3/8