

TYPE	SIZE	UNIT STYLE
X	3E	PO

DIMENSIONS 101-111	
Section Effective	101 Sep 2023
Replaces	Feb 2003
Page	1/6

RIGHT HAND ROTATION. FOR LEFT HAND ROTATION, SHAFT PROJECTION IS OPPOSITE THAT SHOWN.

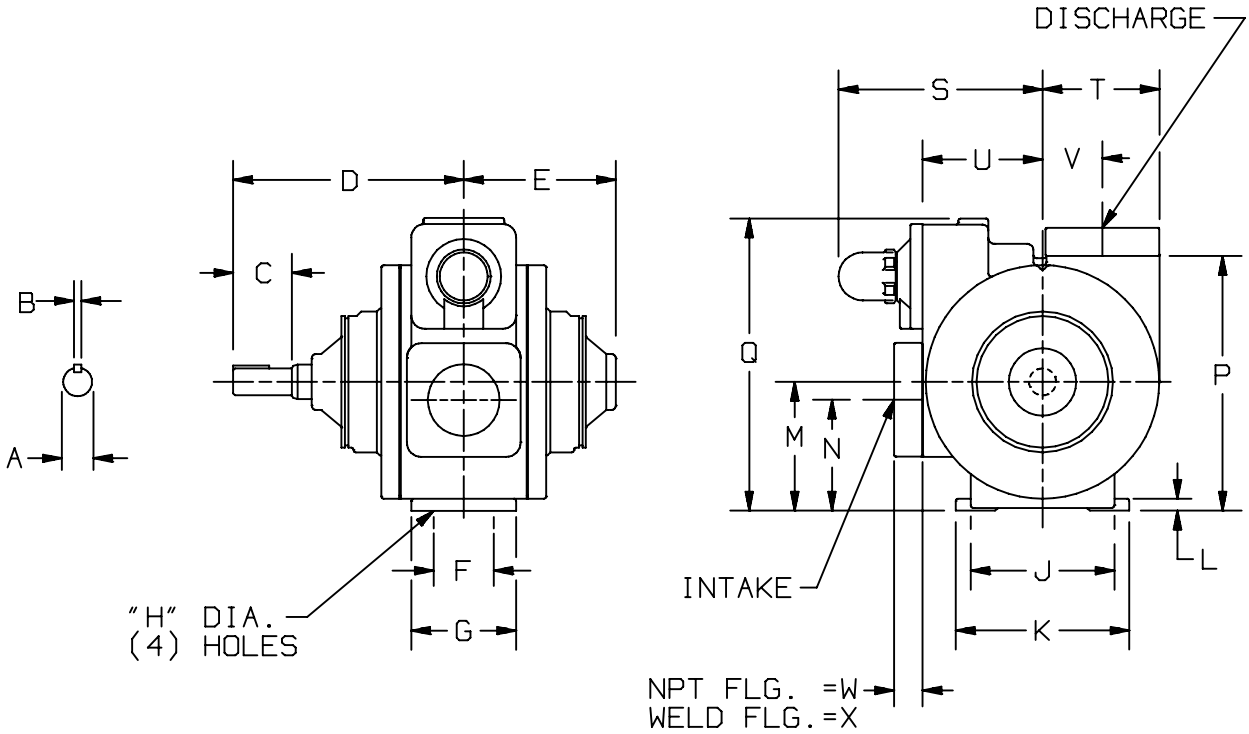

MOTOR			UNITS	DIMENSIONS									
FRAME SIZE				A	B	C	D	E	F	G	H	J	K
			IN	1 1/8	1/4	2 1/2	9 5/8	6 3/8	2 1/2	4 3/8	5/8	6	7 1/4
			MM	28,6	6,4	63,5	244,5	161,9	63,5	111,1	15,9	152,4	184,2
				L	M	N	P	Q	R	S	T	U	V
			IN	1/2	5 3/8	4 5/8	10 5/8	12 1/4	—	8 9/16	4 7/8	5	2 1/2
			MM	12,7	136,6	117,5	269,9	311,2	—	217,5	123,8	127	63,5
				W	X	Y	Z	AA	BB	CC	DD	EE	FF
			IN	1 1/8	1 3/16	—	—	—	—	—	—	—	—
			MM	28,6	30,2	—	—	—	—	—	—	—	—
				GG	HH					PUMP WEIGHT	WITH STD. FLANGES		
			IN	—	—					LBS	152		
			MM	—	—					KG	69		

NOTE: FOR ANSI AND DIN FLANGE DIMENSIONS, SEE DIMENSION SHEET 101-113



www.blackmer.com

TYPE

SIZE

UNIT
STYLE

DIMENSIONS 101-111

X

3E

HRA

Section 101
Effective Sep 2023
Replaces Feb 2003
Page 3/6

RIGHT HAND ROTATION

(4) $\varnothing \frac{5}{8}$ ANCHOR HOLES

DISCHARGE
SPECIAL
BLACKMER
FLG. REQD.

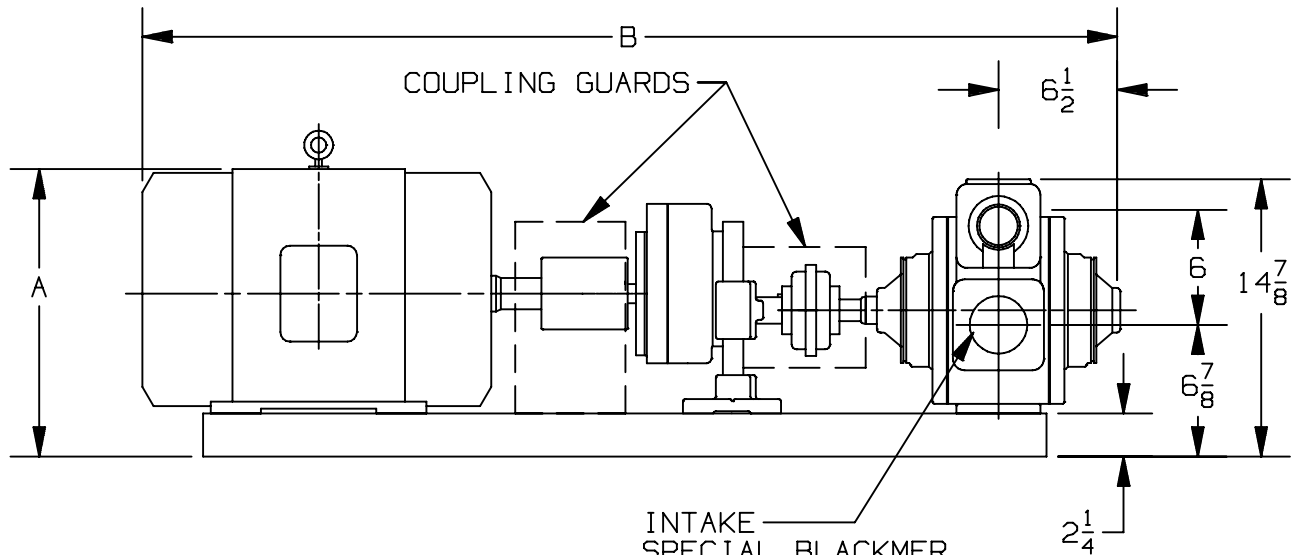
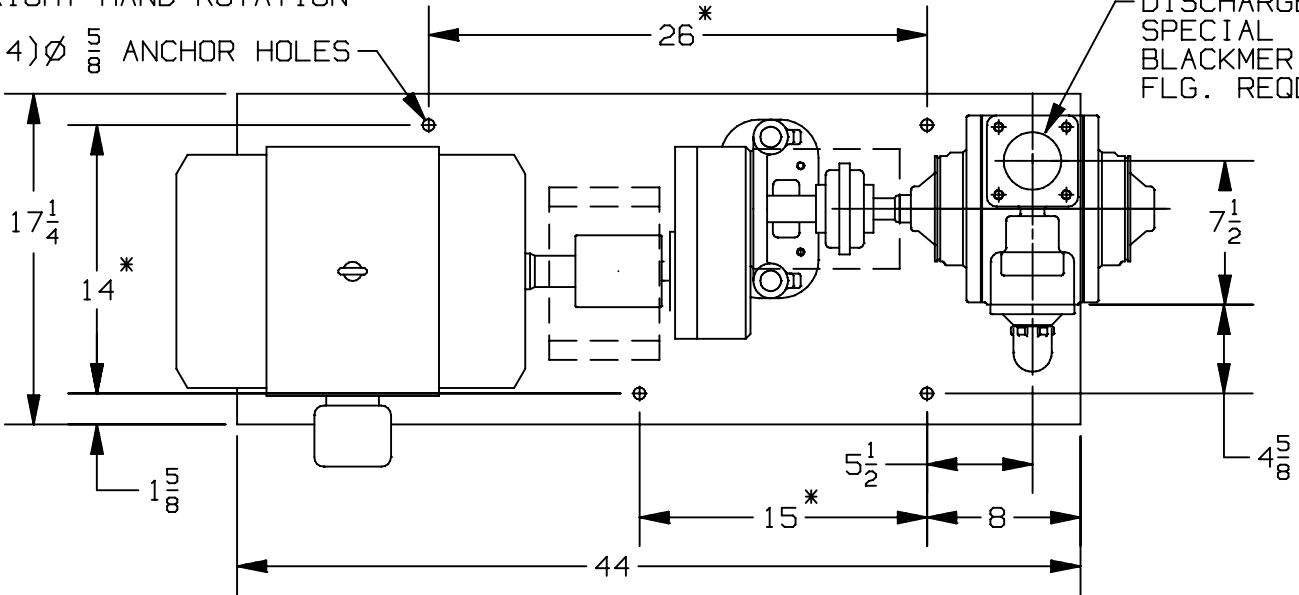

UNIT DIMENSION LESS FLANGES

* TOLERANCE $\pm \frac{1}{8}$

TOLERANCE ON OTHER DIMENSIONS $\pm \frac{1}{4}$

"A" DIMENSION LESS EYEBOLT

INTAKE
SPECIAL BLACKMER
FLG. REQD

FLG. HT: 3" NPT - 1 1/8
3" WELD- 1 3/16

MOTOR			BASE NO.	DIMENSIONS		
FRAME SIZE		UNITS		A	B	
182T		901774	IN	11 7/8	48 3/4	
184T		901774	IN	11 7/8	48 3/4	
213T		901774	IN	13 3/8	48 3/4	
215T		901774	IN	13 3/8	49 3/8	
254T		901774	IN	15 5/8	53 1/4	
256T		901774	IN	15 5/8	55	

DIMENSIONS 101-111

Section 101
 Effective Sep 2023
 Replaces Feb 2003
 Page 4/6

TYPE

SIZE

UNIT
STYLE

X

3E

HRA



www.blackmer.com

LEFT HAND ROTATION

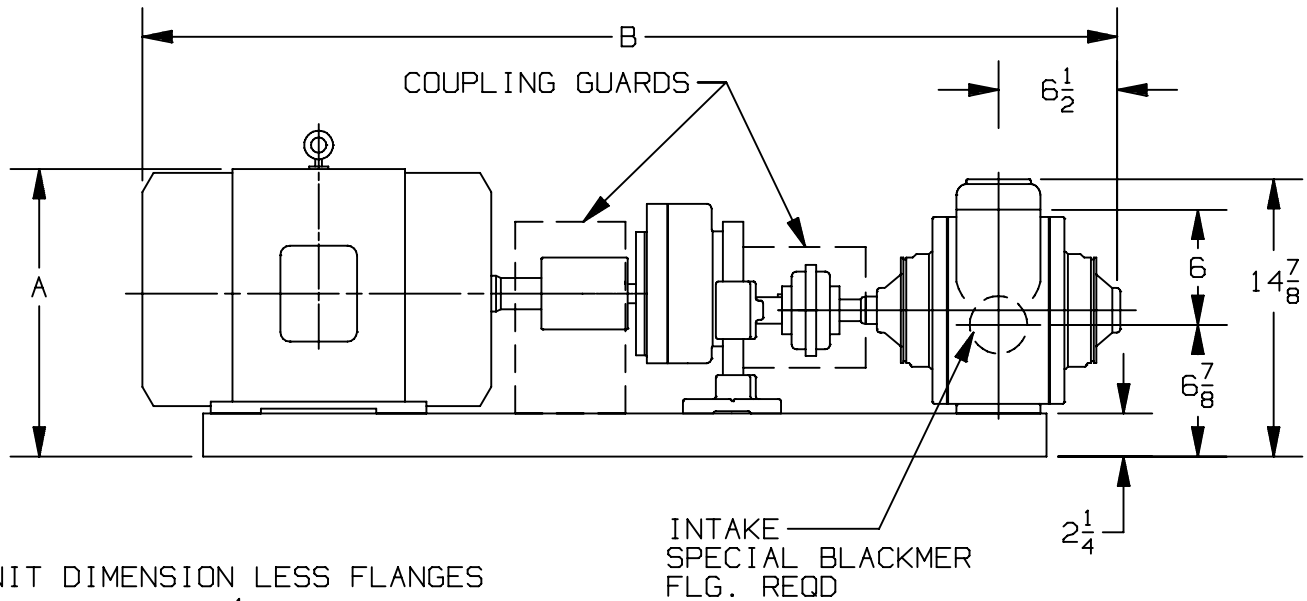
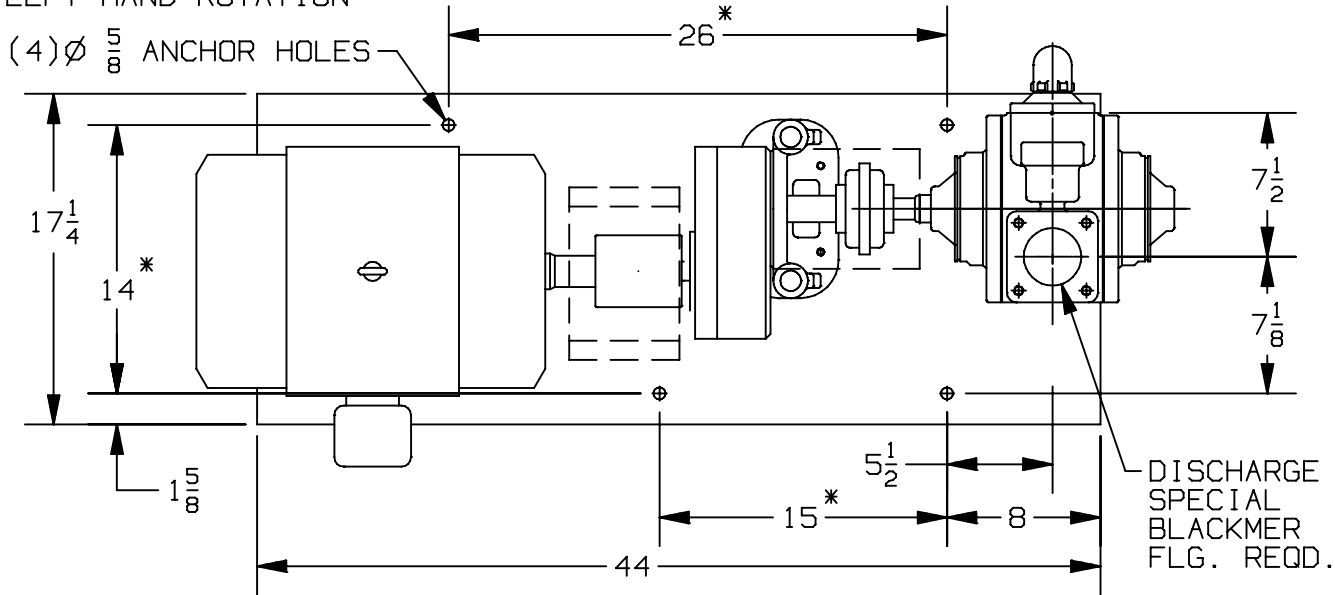

UNIT DIMENSION LESS FLANGES

* TOLERANCE $\pm \frac{1}{8}$

TOLERANCE ON OTHER DIMENSIONS $\pm \frac{1}{4}$

"A" DIMENSION LESS EYEBOLT

FLG. HT: 3" NPT - 1 1/8
 3" WELD- 1 3/16

MOTOR			BASE NO.	DIMENSIONS		
FRAME SIZE		UNITS		A	B	
182T		901774	IN	11 7/8	48 3/4	
184T		901774	IN	11 7/8	48 3/4	
213T		901774	IN	13 3/8	48 3/4	
215T		901774	IN	13 3/8	49 3/8	
254T		901774	IN	15 5/8	53 1/4	
256T		901774	IN	15 5/8	55	



www.blackmer.com

TYPE	SIZE	UNIT STYLE
X	3E	HRB

DIMENSIONS 101-111

Section 101
 Effective Sep 2023
 Replaces Mar 2006
 Page 5/6

RIGHT HAND ROTATION

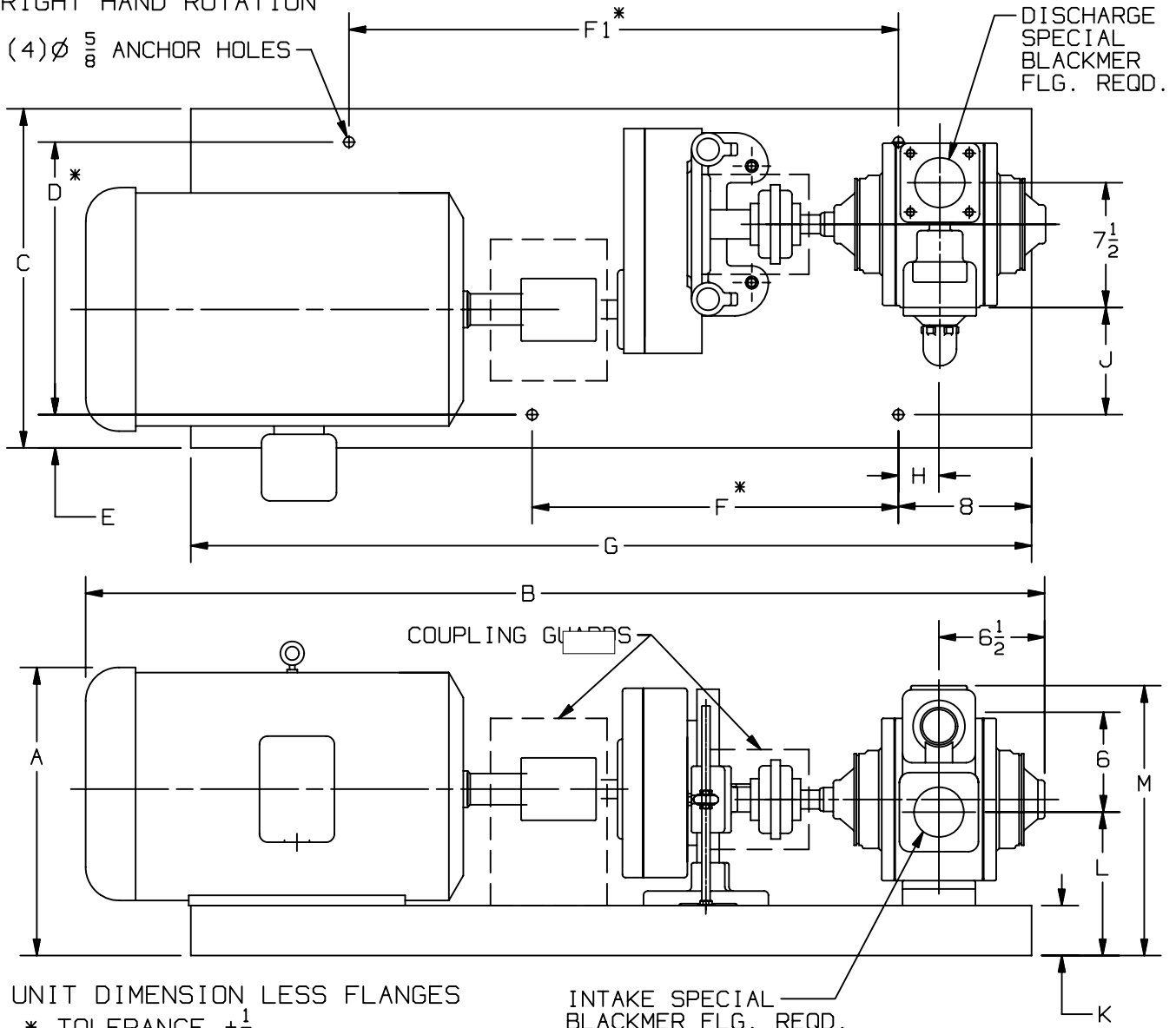

UNIT DIMENSION LESS FLANGES

* TOLERANCE $\pm \frac{1}{8}$

TOLERANCE ON OTHER DIMENSIONS $\pm \frac{1}{4}$

"A" DIMENSION LESS EYEBOLT

FLG. HT: 3" NPT - 1 1/8
 3" WELD- 1 3/16

MOTOR			BASE NO.	DIMENSIONS												
FRAME SIZE				UNITS	A	B	C	D	E	F	F1	G	H	J	K	L
182T		901772	IN	12 ⁷ / ₈	46 ¹ / ₈	17 ¹ / ₄	14	1 ⁵ / ₈	15	26	44	2 ³ / ₈	4 ⁵ / ₈	2 ¹ / ₄	7 ⁷ / ₈	15 ⁷ / ₈
184T		901772	IN	12 ⁷ / ₈	47 ¹ / ₂	17 ¹ / ₄	14	1 ⁵ / ₈	15	26	44	2 ³ / ₈	4 ⁵ / ₈	2 ¹ / ₄	7 ⁷ / ₈	15 ⁷ / ₈
213T		901772	IN	13 ⁵ / ₈	49 ¹ / ₂	17 ¹ / ₄	14	1 ⁵ / ₈	15	26	44	2 ³ / ₈	4 ⁵ / ₈	2 ¹ / ₄	7 ⁷ / ₈	15 ⁷ / ₈
215T		901772	IN	13 ⁵ / ₈	50 ¹ / ₄	17 ¹ / ₄	14	1 ⁵ / ₈	15	26	44	2 ³ / ₈	4 ⁵ / ₈	2 ¹ / ₄	7 ⁷ / ₈	15 ⁷ / ₈
254T		901773	IN	16 ³ / ₈	54	20 ³ / ₈	16 ³ / ₈	2	22	33	50 ¹ / ₂	2 ¹ / ₂	6 ¹ / ₂	3	8 ⁵ / ₈	16 ³ / ₄
256T		901773	IN	16 ³ / ₈	55 ³ / ₄	20 ³ / ₈	16 ³ / ₈	2	22	33	50 ¹ / ₂	2 ¹ / ₂	6 ¹ / ₂	3	8 ⁵ / ₈	16 ³ / ₄
284T		901773	IN	18	57 ³ / ₄	20 ³ / ₈	16 ³ / ₈	2	22	33	50 ¹ / ₂	2 ¹ / ₂	6 ¹ / ₂	3	8 ⁵ / ₈	16 ³ / ₄
286T		901773	IN	18	59 ¹ / ₄	20 ³ / ₈	16 ³ / ₈	2	22	33	50 ¹ / ₂	2 ¹ / ₂	6 ¹ / ₂	3	8 ⁵ / ₈	16 ³ / ₄

DIMENSIONS 101-111

Section 101
 Effective Sep 2023
 Replaces Mar 2006
 Page 6/6

TYPE

SIZE

UNIT
STYLE

X

3E

HRB



www.blackmer.com

LEFT HAND ROTATION

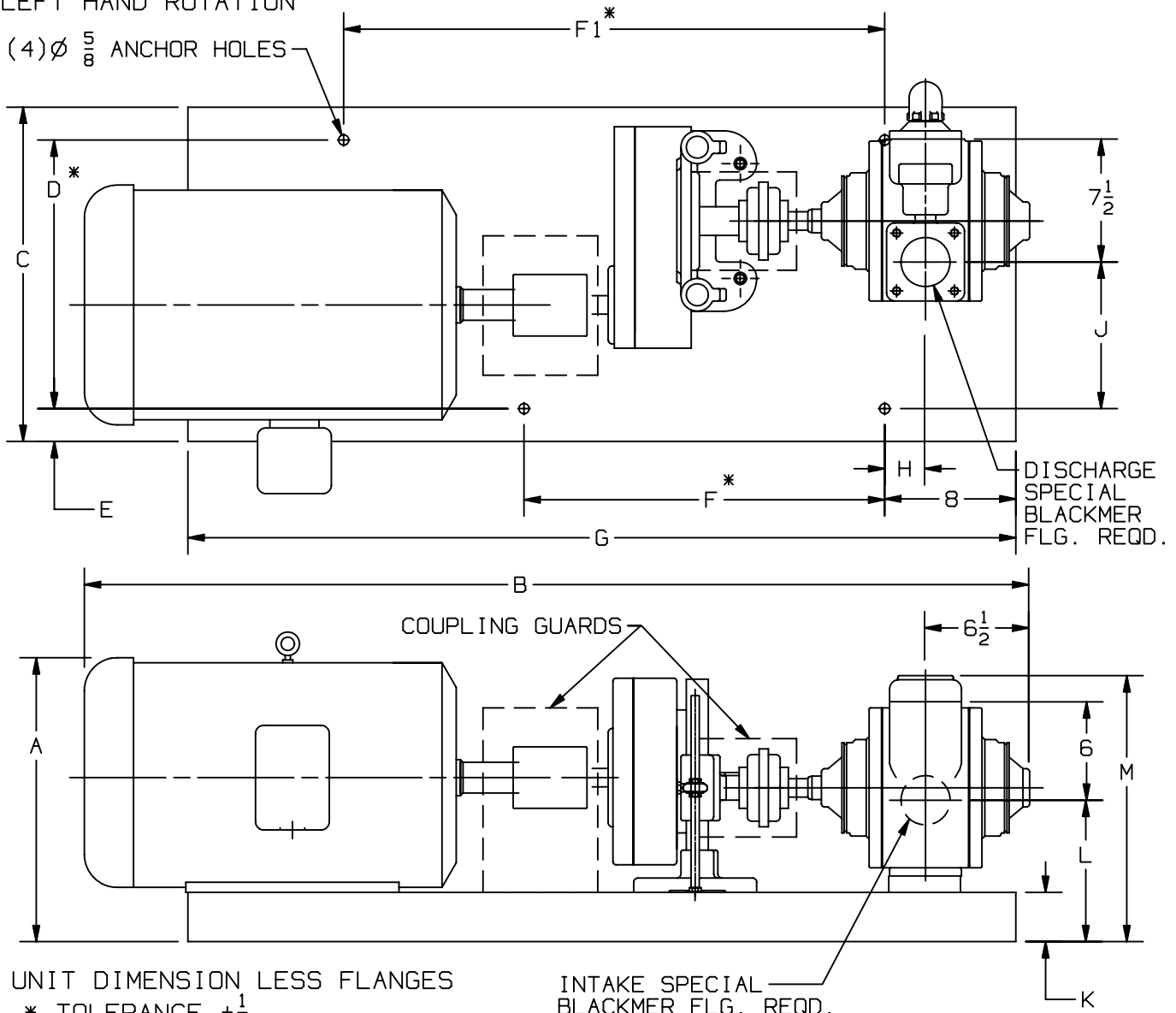

UNIT DIMENSION LESS FLANGES

* TOLERANCE $\pm \frac{1}{8}$

TOLERANCE ON OTHER DIMENSIONS $\pm \frac{1}{4}$

"A" DIMENSION LESS EYEBOLT

INTAKE SPECIAL BLACKMER FLG. REQD.

FLG. HT: 3" NPT - 1 1/8
 3" WELD- 1 3/16

MOTOR			BASE NO.	DIMENSIONS													
FRAME SIZE				UNITS	A	B	C	D	E	F	F1	G	H	J	K	L	M
182T			901772	IN	12 ⁷ / ₈	46 ¹ / ₈	17 ¹ / ₄	14	1 ⁵ / ₈	15	26	44	2 ³ / ₈	7 ¹ / ₈	2 ¹ / ₄	7 ⁷ / ₈	15 ⁷ / ₈
184T			901772	IN	12 ⁷ / ₈	47 ¹ / ₂	17 ¹ / ₄	14	1 ⁵ / ₈	15	26	44	2 ³ / ₈	7 ¹ / ₈	2 ¹ / ₄	7 ⁷ / ₈	15 ⁷ / ₈
213T			901772	IN	13 ⁵ / ₈	49 ¹ / ₂	17 ¹ / ₄	14	1 ⁵ / ₈	15	26	44	2 ³ / ₈	7 ¹ / ₈	2 ¹ / ₄	7 ⁷ / ₈	15 ⁷ / ₈
215T			901772	IN	13 ⁵ / ₈	50 ¹ / ₄	17 ¹ / ₄	14	1 ⁵ / ₈	15	26	44	2 ³ / ₈	7 ¹ / ₈	2 ¹ / ₄	7 ⁷ / ₈	15 ⁷ / ₈
254T			901773	IN	16 ³ / ₈	54	20 ³ / ₈	16 ³ / ₈	2	22	33	50 ¹ / ₂	2 ¹ / ₂	9	3	8 ⁵ / ₈	16 ³ / ₄
256T			901773	IN	16 ³ / ₈	55 ³ / ₄	20 ³ / ₈	16 ³ / ₈	2	22	33	50 ¹ / ₂	2 ¹ / ₂	9	3	8 ⁵ / ₈	16 ³ / ₄
284T			901773	IN	18	57 ³ / ₄	20 ³ / ₈	16 ³ / ₈	2	22	33	50 ¹ / ₂	2 ¹ / ₂	9	3	8 ⁵ / ₈	16 ³ / ₄
286T			901773	IN	18	59 ¹ / ₄	20 ³ / ₈	16 ³ / ₈	2	22	33	50 ¹ / ₂	2 ¹ / ₂	9	3	8 ⁵ / ₈	16 ³ / ₄