



|      |      |            |                                       |                                       |
|------|------|------------|---------------------------------------|---------------------------------------|
| TYPE | SIZE | UNIT STYLE | DIMENSIONS 101-119                    |                                       |
| XH   | 2B   | PO         | Section Effective Replaces Page 1 / 8 | 101<br>SEPTEMBER 2023<br>OCTOBER 2015 |

RIGHT HAND ROTATION. FOR LEFT HAND ROTATION, SHAFT PROJECTION IS OPPOSITE THAT SHOWN.

\*TOLERANCE  $\pm 1/8"$

TOLERANCE ON OTHER DIMENSIONS  $\pm 1/4"$

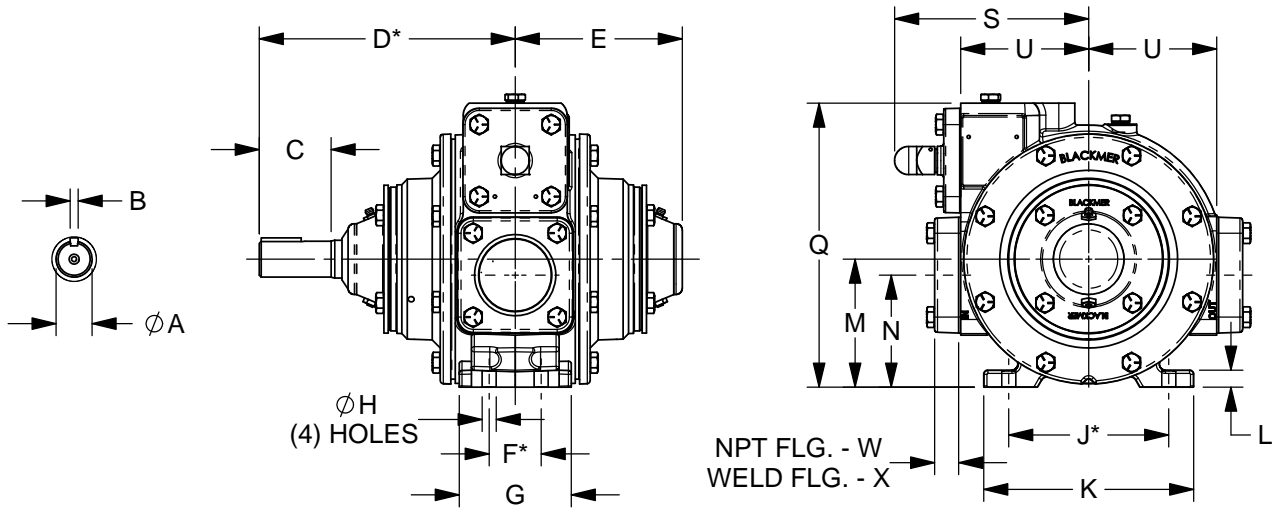

NOTE: FOR ANSI AND DIN FLANGE DIMENSIONS, SEE DIMENSION SHEET 101-113.

| DIMENSIONS |       |        |       |       |       |       |        |      |       |        | WEIGHTS |                 |
|------------|-------|--------|-------|-------|-------|-------|--------|------|-------|--------|---------|-----------------|
| UNITS      | A     | B      | C     | D     | E     | F     | G      | H    | J     | K      | UNITS   | PUMP ONLY       |
| IN         | 1 1/8 | 1/4    | 2 1/4 | 8     | 5 1/4 | 1 5/8 | 3 1/2  | 7/16 | 5     | 6 9/16 | LBS     | 65              |
| MM         | ---   | ---    | 57,2  | 203,2 | 133,4 | 41,3  | 88,9   | 11,1 | 127   | 166,7  | KG      | 29              |
|            | L     | M      | N     | P     | Q     | R     | S      | T    | U     | V      |         | W/ NPT FLANGES  |
| IN         | 1/2   | 4      | 3 1/2 | ---   | 8 7/8 | ---   | 6 1/16 | ---  | 4     | ---    | LBS     | 70              |
| MM         | 12,7  | 101,6  | 88,9  | ---   | 225,4 | ---   | 154    | ---  | 101,6 | ---    | KG      | 32              |
|            | W     | X      | Y     | Z     | AA    | BB    | CC     | DD   | EE    | FF     |         | W/ WELD FLANGES |
| IN         | 3/4   | 1 3/16 | ---   | ---   | ---   | ---   | ---    | ---  | ---   | ---    | LBS     | 71              |
| MM         | 19,1  | 30,2   | ---   | ---   | ---   | ---   | ---    | ---  | ---   | ---    | KG      | 32              |
|            | GG    | HH     | JJ    | KK    | LL    | MM    |        |      |       |        |         | W/ ANSI FLANGES |
| IN         | ---   | ---    | ---   | ---   | ---   | ---   |        |      |       |        | LBS     | 86              |
| MM         | ---   | ---    | ---   | ---   | ---   | ---   |        |      |       |        | KG      | 39              |





|      |      |            |
|------|------|------------|
| TYPE | SIZE | UNIT STYLE |
| XH   | 2B   | HROF       |

|                                       |                                       |
|---------------------------------------|---------------------------------------|
| DIMENSIONS 101-119                    |                                       |
| Section Effective Replaces Page 3 / 8 | 101<br>SEPTEMBER 2023<br>OCTOBER 2015 |

RIGHT HAND ROTATION SHOWN.

\*TOLERANCE  $\pm 1/8"$

TOLERANCE ON OTHER DIMENSIONS  $\pm 1/4"$

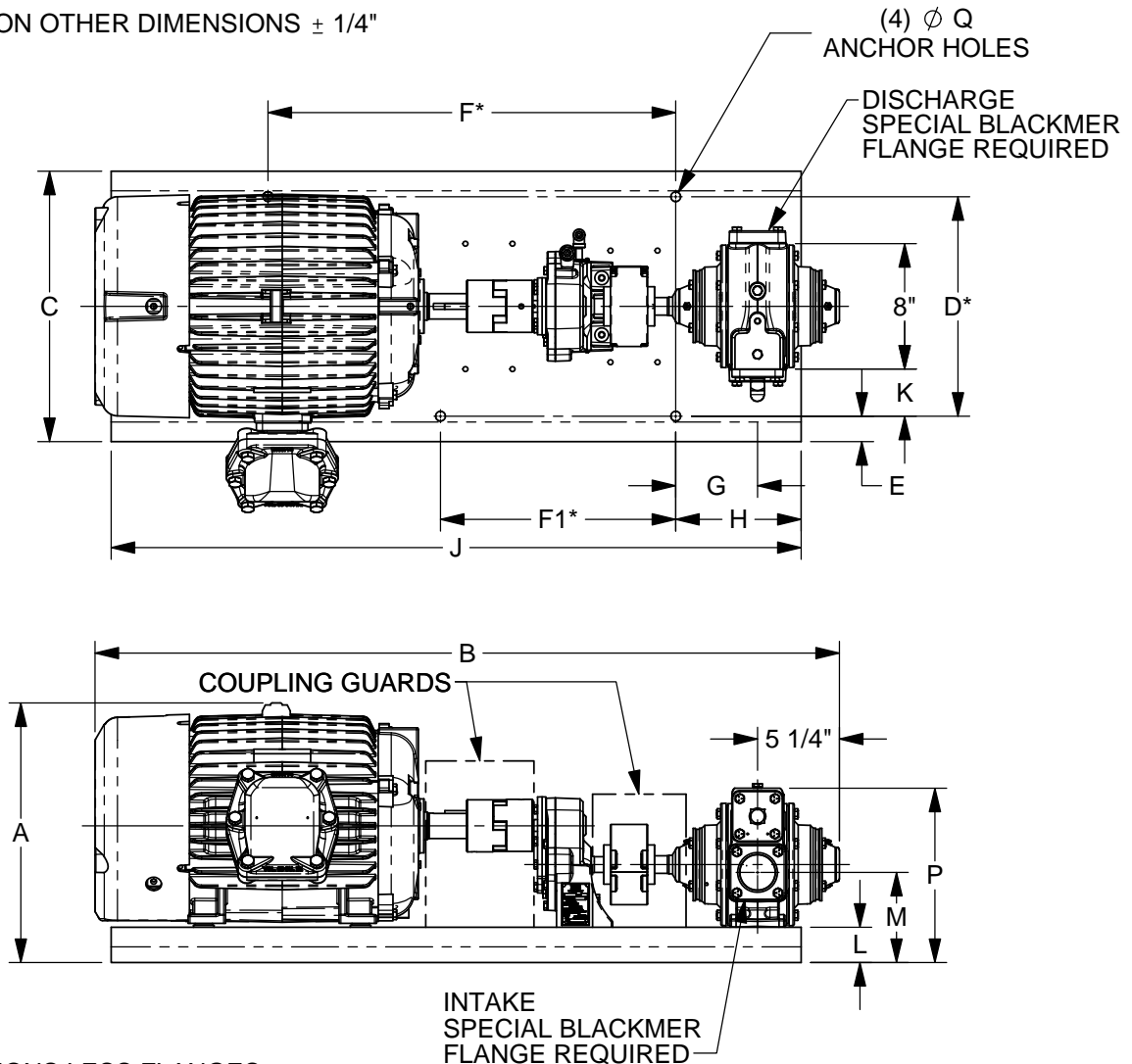

UNIT DIMENSIONS LESS FLANGES

"A" DIMENSION LESS MOTOR EYEBOLT

FLANGE HT. 2" NPT - 3/4  
2" WELD - 1 3/16

| MOTOR      |       |      | BASE NO. | DIMENSIONS |         |        |    |       |    |    |       |   |    |   |       |       |        |      |            | APPROX. UNIT WT. - POUNDS |  |
|------------|-------|------|----------|------------|---------|--------|----|-------|----|----|-------|---|----|---|-------|-------|--------|------|------------|---------------------------|--|
| FRAME SIZE | H.P.  | RPM  |          | A          | B       | C      | D  | E     | F  | F1 | G     | H | J  | K | L     | M     | P      | Q    | LESS MOTOR | INCL MOTOR                |  |
| 143T       | 1     | 1800 | 901790   | 12 1/4     | 36 1/8  | 14 3/4 | 10 | 2 3/8 | 12 | 12 | 3 1/4 | 6 | 33 | 1 | 1 3/4 | 5 1/4 | 10 5/8 | 7/16 | 182        | 220                       |  |
| 145T       | 2     | 1800 | 901790   | 12 1/4     | 36 1/8  | 14 3/4 | 10 | 2 3/8 | 12 | 12 | 3 1/4 | 6 | 33 | 1 | 1 3/4 | 5 1/4 | 10 5/8 | 7/16 | 182        | 243                       |  |
| 182T       | 3     | 1800 | 901790   | 13 5/16    | 37 5/16 | 14 3/4 | 10 | 2 3/8 | 12 | 12 | 3 1/4 | 6 | 33 | 1 | 1 3/4 | 5 1/4 | 10 5/8 | 7/16 | 182        | 302                       |  |
| 184T       | 5     | 1800 | 901790   | 13 5/16    | 37 5/16 | 14 3/4 | 10 | 2 3/8 | 12 | 12 | 3 1/4 | 6 | 33 | 1 | 1 3/4 | 5 1/4 | 10 5/8 | 7/16 | 182        | 309                       |  |
| 213T       | 7 1/2 | 1800 | 901791   | 14 5/8     | 41 9/16 | 17 1/4 | 14 | 1 5/8 | 26 | 15 | 5 1/4 | 8 | 44 | 3 | 2 1/4 | 5 3/4 | 11 1/8 | 5/8  | 231        | 453                       |  |
| 215T       | 10    | 1800 | 901791   | 14 5/8     | 41 9/16 | 17 1/4 | 14 | 1 5/8 | 26 | 15 | 5 1/4 | 8 | 44 | 3 | 2 1/4 | 5 3/4 | 11 1/8 | 5/8  | 231        | 471                       |  |
| 254T       | 15    | 1800 | 901791   | 16 9/16    | 45 3/4  | 17 1/4 | 14 | 1 5/8 | 26 | 15 | 5 1/4 | 8 | 44 | 3 | 2 1/4 | 5 3/4 | 11 1/8 | 5/8  | 231        | 586                       |  |
| 256T       | 20    | 1800 | 901791   | 16 9/16    | 47 1/2  | 17 1/4 | 14 | 1 5/8 | 26 | 15 | 5 1/4 | 8 | 44 | 3 | 2 1/4 | 5 3/4 | 11 1/8 | 5/8  | 231        | 629                       |  |



|      |      |            |
|------|------|------------|
| TYPE | SIZE | UNIT STYLE |
| XH   | 2B   | HROF       |

|                    |                |
|--------------------|----------------|
| DIMENSIONS 101-119 |                |
| Section Effective  | 101            |
| Replaces           | SEPTEMBER 2023 |
| Page 4 / 8         | OCTOBER 2015   |

LEFT HAND ROTATION SHOWN.

\*TOLERANCE  $\pm 1/8"$

TOLERANCE ON OTHER DIMENSIONS  $\pm 1/4"$

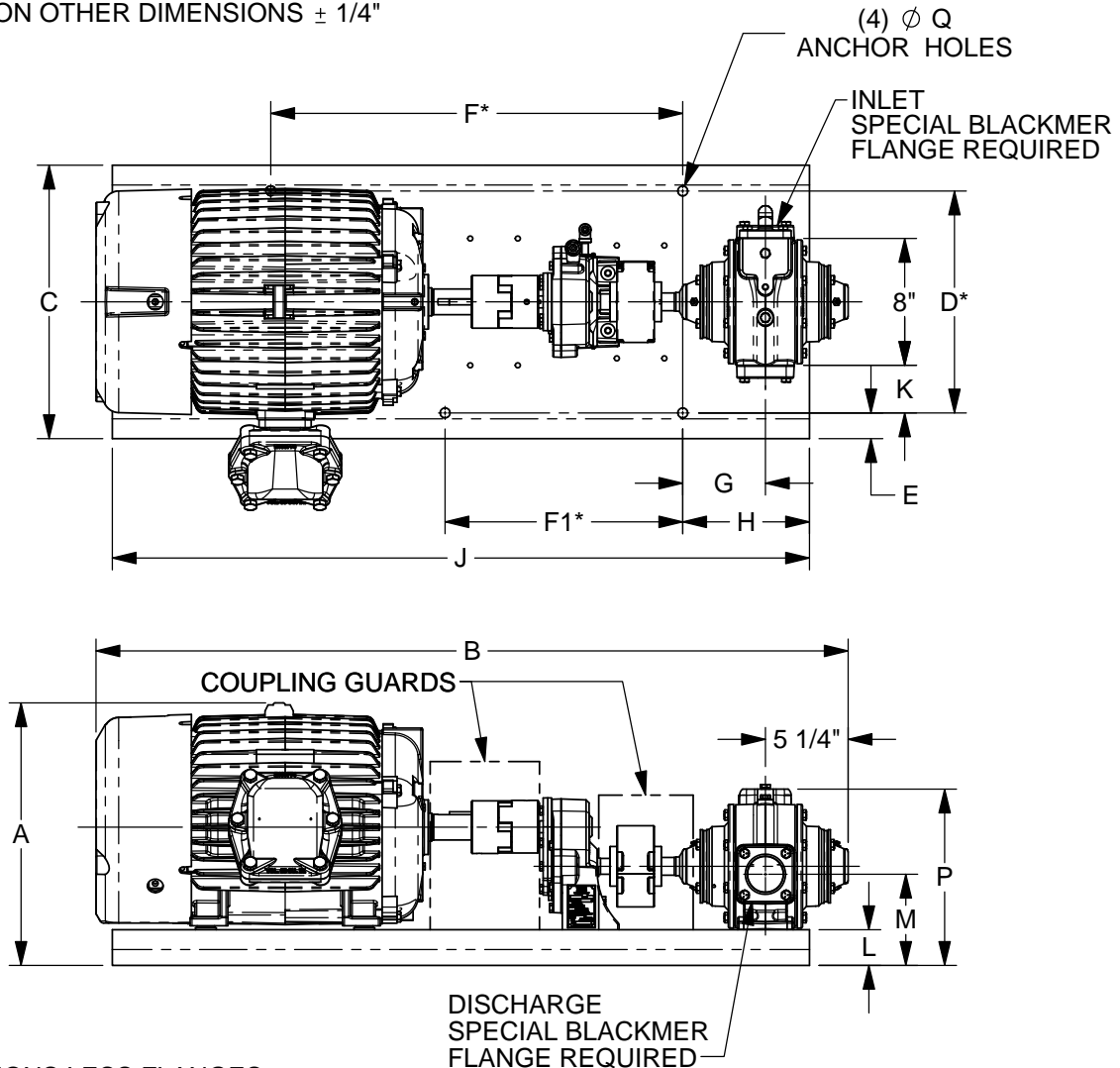

UNIT DIMENSIONS LESS FLANGES

"A" DIMENSION LESS MOTOR EYEBOLT

FLANGE HT. 2" NPT - 3/4  
2" WELD - 1 3/16

| MOTOR      |       |      | BASE NO. | DIMENSIONS |         |        |    |       |    |    |       |   |    |   |       |       |        |      |            | APPROX. UNIT WT. - POUNDS |  |
|------------|-------|------|----------|------------|---------|--------|----|-------|----|----|-------|---|----|---|-------|-------|--------|------|------------|---------------------------|--|
| FRAME SIZE | H.P.  | RPM  |          | A          | B       | C      | D  | E     | F  | F1 | G     | H | J  | K | L     | M     | P      | Q    | LESS MOTOR | INCL MOTOR                |  |
| 143T       | 1     | 1800 | 901790   | 12 1/4     | 36 1/8  | 14 3/4 | 10 | 2 3/8 | 12 | 12 | 3 1/4 | 6 | 33 | 1 | 1 3/4 | 5 1/4 | 10 5/8 | 7/16 | 182        | 220                       |  |
| 145T       | 2     | 1800 | 901790   | 12 1/4     | 36 1/8  | 14 3/4 | 10 | 2 3/8 | 12 | 12 | 3 1/4 | 6 | 33 | 1 | 1 3/4 | 5 1/4 | 10 5/8 | 7/16 | 182        | 243                       |  |
| 182T       | 3     | 1800 | 901790   | 13 5/16    | 37 5/16 | 14 3/4 | 10 | 2 3/8 | 12 | 12 | 3 1/4 | 6 | 33 | 1 | 1 3/4 | 5 1/4 | 10 5/8 | 7/16 | 182        | 302                       |  |
| 184T       | 5     | 1800 | 901790   | 13 5/16    | 37 5/16 | 14 3/4 | 10 | 2 3/8 | 12 | 12 | 3 1/4 | 6 | 33 | 1 | 1 3/4 | 5 1/4 | 10 5/8 | 7/16 | 182        | 309                       |  |
| 213T       | 7 1/2 | 1800 | 901791   | 14 5/8     | 41 9/16 | 17 1/4 | 14 | 1 5/8 | 26 | 15 | 5 1/4 | 8 | 44 | 3 | 2 1/4 | 5 3/4 | 11 1/8 | 5/8  | 231        | 453                       |  |
| 215T       | 10    | 1800 | 901791   | 14 5/8     | 41 9/16 | 17 1/4 | 14 | 1 5/8 | 26 | 15 | 5 1/4 | 8 | 44 | 3 | 2 1/4 | 5 3/4 | 11 1/8 | 5/8  | 231        | 471                       |  |
| 254T       | 15    | 1800 | 901791   | 16 9/16    | 45 3/4  | 17 1/4 | 14 | 1 5/8 | 26 | 15 | 5 1/4 | 8 | 44 | 3 | 2 1/4 | 5 3/4 | 11 1/8 | 5/8  | 231        | 586                       |  |
| 256T       | 20    | 1800 | 901791   | 16 9/16    | 47 1/2  | 17 1/4 | 14 | 1 5/8 | 26 | 15 | 5 1/4 | 8 | 44 | 3 | 2 1/4 | 5 3/4 | 11 1/8 | 5/8  | 231        | 629                       |  |







