



TYPE	SIZE	UNIT STYLE
GNX	4	PO

DIMENSIONS 101-208	
Section Effective Replaces Page 1 / 3	101 SEPT 2019 SEPT 2018

RIGHT HAND ROTATION. FOR LEFT HAND ROTATION, SHAFT PROJECTION IS OPPOSITE THAT SHOWN.

*TOLERANCE $\pm 1/8"$

TOLERANCE ON OTHER DIMENSIONS $\pm 1/4"$

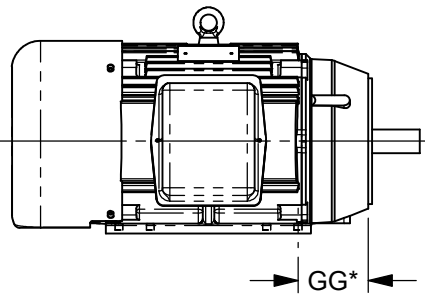
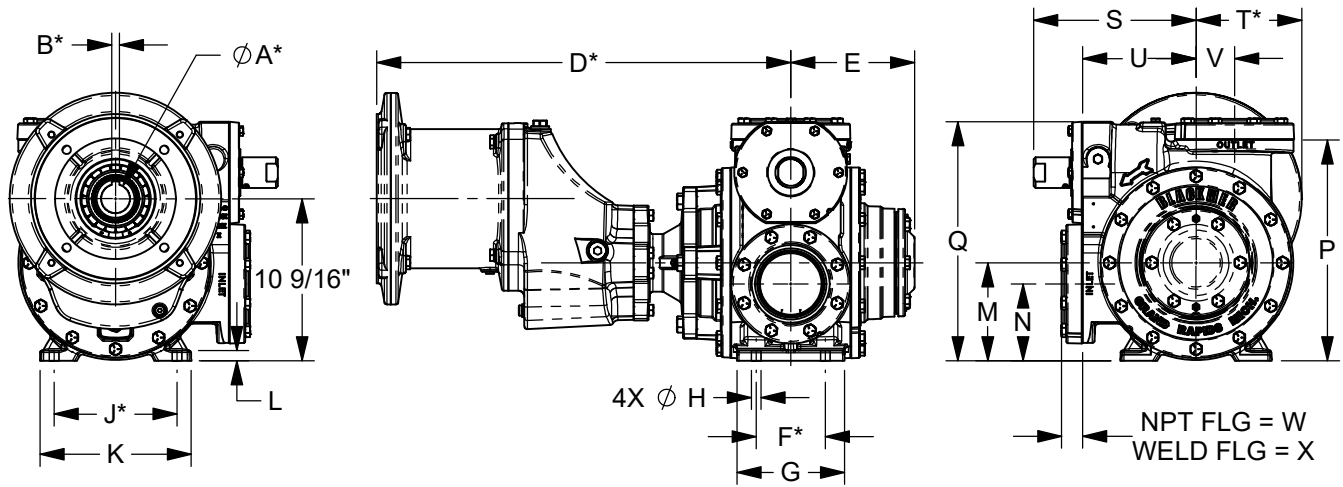

MOTOR SIZE	ϕA^*	B*	D*	T*	GG*
NEMA 210TC	1 3/8	5/16	26 5/16	5 1/16	4 1/4
NEMA 250TC	1 5/8	3/8	26 5/16	5 1/16	4 3/4
NEMA 280TC	1 7/8	1/2	26 15/16	6 7/8	4 3/4
NEMA 320TC	2 1/8	1/2	29 3/8	6 7/8	5 1/4

DIMENSIONS											WEIGHTS	
UNITS	A	B	C	D	E	F	G	H	J	K	UNITS	PUMP ONLY
IN	---	---	---	---	8 1/16	4 1/2	7	5/8	8	9 7/8	LBS	310
MM	---	---	---	---	204,8	114,3	177,8	15,9	203,2	250,8	KG	141
	L	M	N	P	Q	R	S	T	U	V		NPT FLANGES
IN	5/8	6 3/8	5	14 3/8	15 9/16	---	10 9/16	---	7 3/8	2 1/2	LBS	328
MM	15,9	161,9	127	365,1	395,3	---	268,3	---	187,3	63,5	KG	149
	W	X	Y	Z	AA	BB	CC	DD	EE	FF		WELD FLANGES
IN	1 3/8	3	---	---	---	---	---	---	---	---	LBS	333
MM	34,9	76,2	---	---	---	---	---	---	---	---	KG	151
	GG	HH	JJ	KK	LL	MM						ANSI FLANGES
IN	---	---	---	---	---	---					LBS	360
MM	---	---	---	---	---	---					KG	163



TYPE	SIZE	UNIT STYLE
GNX	4	GNX

DIMENSIONS 101-208	
Section Effective Replaces Page 2 / 3	101 SEPT 2019 SEPT 2018

RIGHT HAND ROTATION SHOWN.

BENT STEEL BASEPLATE

*TOLERANCE $\pm 1/8"$

TOLERANCE ON OTHER DIMENSIONS $\pm 1/4"$

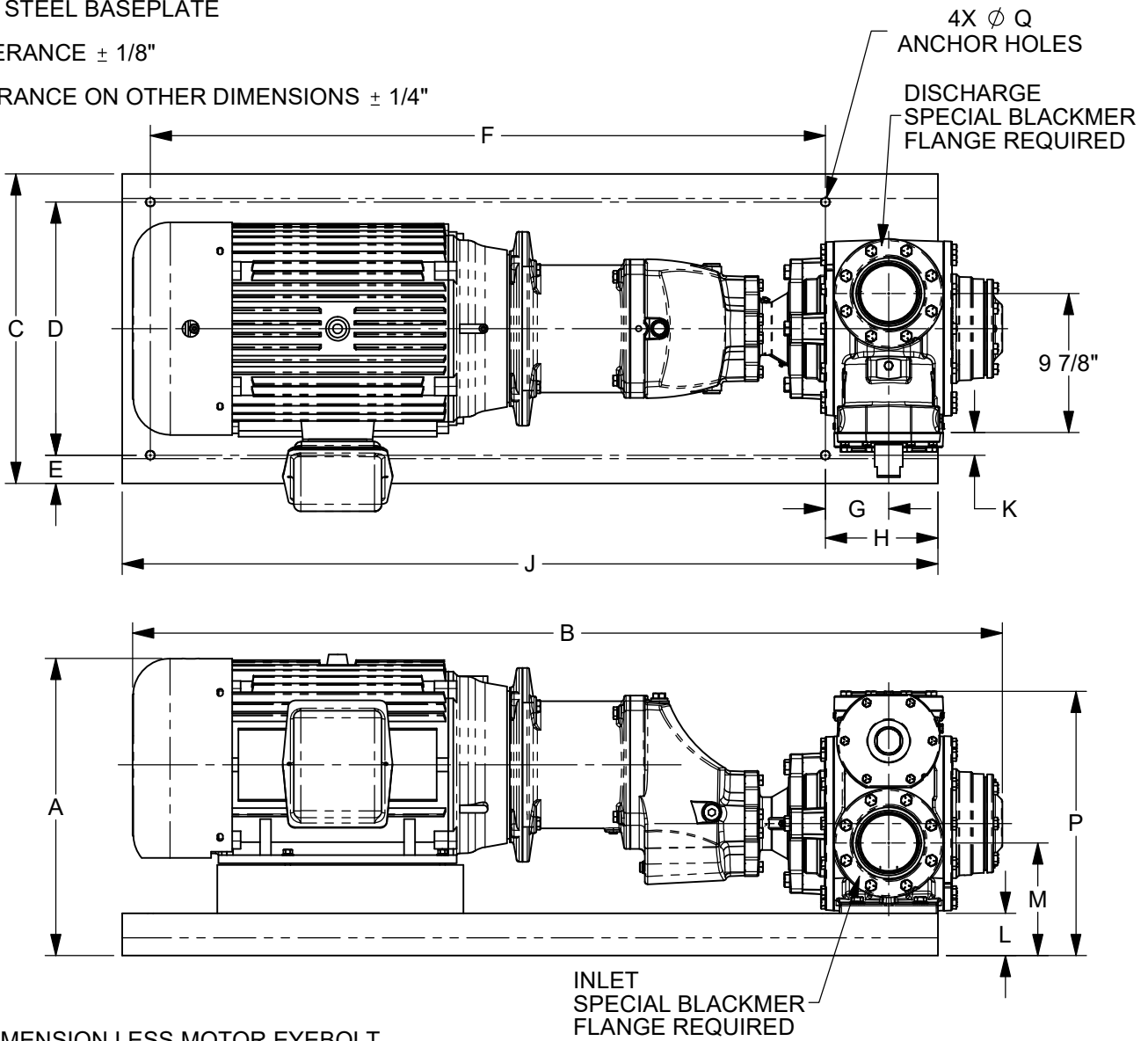

"A" DIMENSION LESS MOTOR EYEBOLT

MOTOR			BASE NO.	DIMENSIONS														APPROX. UNIT WT. - POUNDS	
FRAME SIZE	H.P.	RPM		A	B	C	D	E	F	G	H	J	K	L	M	P	Q	LESS MOTOR	INCL MOTOR
213TC	7 1/2	1800	905624	19	50 5/16	20	16	2	33	4 1/2	8	43	5/8	3	8	18 3/4	5/8	671	832
215TC	10	1800	905624	19	52 1/8	20	16	2	33	4 1/2	8	43	5/8	3	8	18 3/4	5/8	671	854
254TC	15	1800	905625	20 3/8	57 7/16	20	16	2	42	4 1/2	8	52	5/8	3	8	18 3/4	5/8	748	1073
256TC	20	1800	905625	20 3/8	58 11/16	20	16	2	42	4 1/2	8	52	5/8	3	8	18 3/4	5/8	748	1162
284TC	25	1800	905626	21 1/8	60 5/16	22	18	2	48	4 1/2	8	58	1 5/8	3	8	18 3/4	5/8	830	1336
286TC	30	1800	905626	21 1/8	61 13/16	22	18	2	48	4 1/2	8	58	1 5/8	3	8	18 3/4	5/8	830	1371
324TC	40	1800	905627	22 1/8	64	22	18	2	48	4 1/2	8	58	1 5/8	3	8	18 3/4	5/8	900	1565
326TC	50	1800	905627	22 1/8	65 1/4	22	18	2	48	4 1/2	8	58	1 5/8	3	8	18 3/4	5/8	900	1602



TYPE	SIZE	UNIT STYLE
GNX	4	GNX

DIMENSIONS 101-208	
Section Effective Replaces Page 3 / 3	101 SEPT 2019 SEPT 2018

RIGHT HAND ROTATION SHOWN.

BASETEK ® ANSI 252, 258, OR 264 BASE

*TOLERANCE ± 1/8"

TOLERANCE ON OTHER DIMENSIONS ± 1/4"

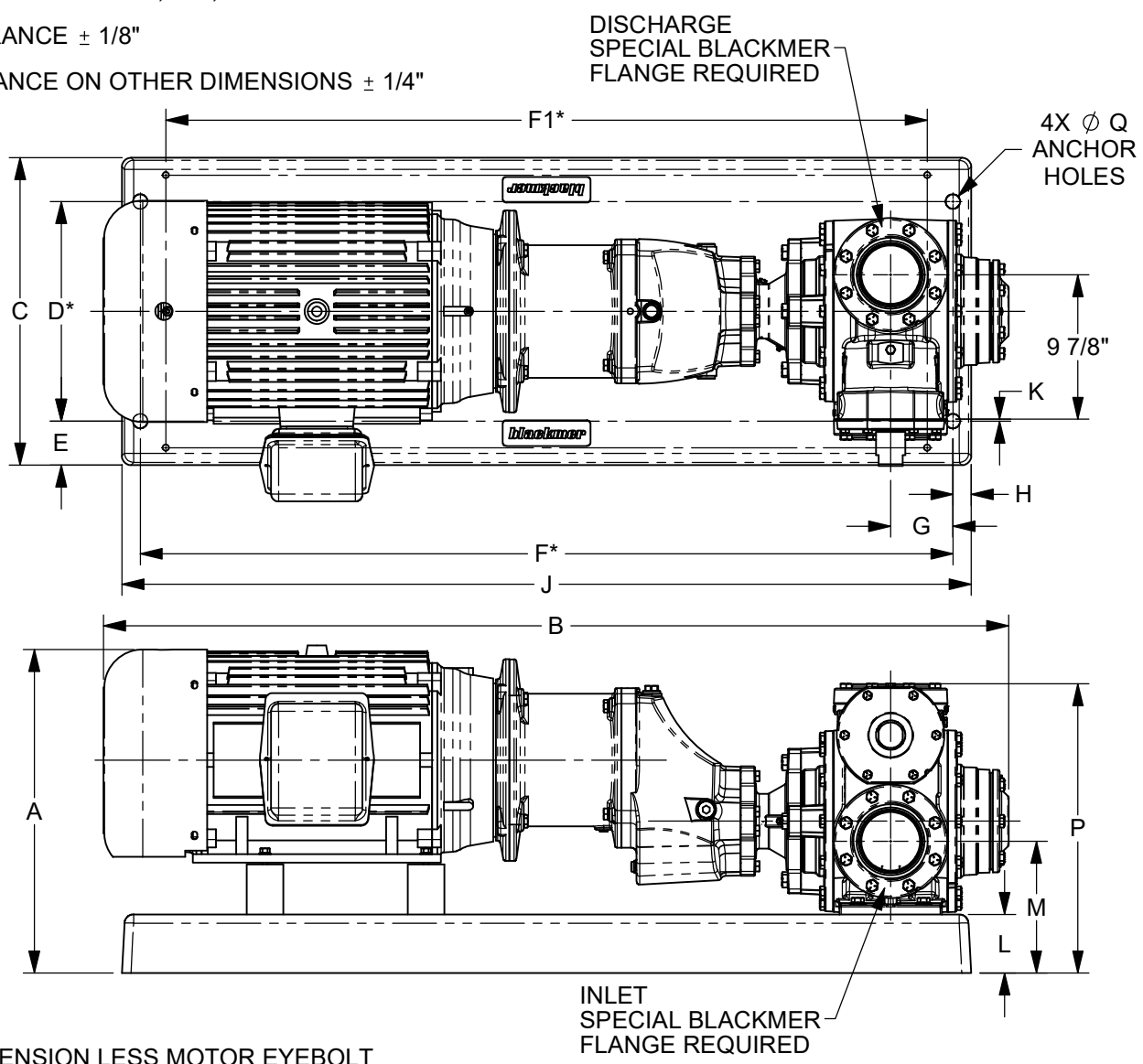

MOTOR			BASE NO.	DIMENSIONS														APPROX. UNIT WT. - POUNDS		
FRAME SIZE	H.P.	RPM		A	B	C	D	E	F	F1	G	H	J	K	L	M	P	Q	LESS MOTOR	INCL MOTOR
215TC	10	1800	905664	20	52 1/8	18	12	3	49 1/2	46	4 1/4	1 1/4	52	1 3/8	4	9	19 3/4	3/4	820	1003
254TC	15	1800	905645	21	57 7/16	21	15	3	55 1/2	52	4 1/4	1 1/4	58	1/8	4	9	19 3/4	1	908	1233
256TC	20	1800	905665	21	58 11/16	21	15	3	55 1/2	52	4 1/4	1 1/4	58	1/8	4	9	19 3/4	1	908	1322
284TC	25	1800	905646	22 1/8	60 5/16	21	15	3	55 1/2	52	4 1/4	1 1/4	58	1/8	4	9	19 3/4	1	948	1454
286TC	30	1800	905666	22 1/8	61 13/16	21	15	3	55 1/2	52	4 1/4	1 1/4	58	1/8	4	9	19 3/4	1	948	1489
324TC	40	1800	905647	23 1/8	64	21	15	3	61 1/2	58	4 1/4	1 1/4	64	1/8	4	9	19 3/4	1	1062	1727
326TC	50	1800	905667	23 1/8	65 1/4	21	15	3	61 1/2	58	4 1/4	1 1/4	64	1/8	4	9	19 3/4	1	1062	1764