



TYPE	SIZE	UNIT STYLE
HXL	6	SK62

DIMENSIONS 102-104	
Section Effective Replaces Page 1/1	102 SEP 2023 NEW

RIGHT HAND ROTATION SHOWN.

*TOLERANCE $\pm 1/8"$

TOLERANCE ON OTHER DIMENSIONS $\pm 1/4"$

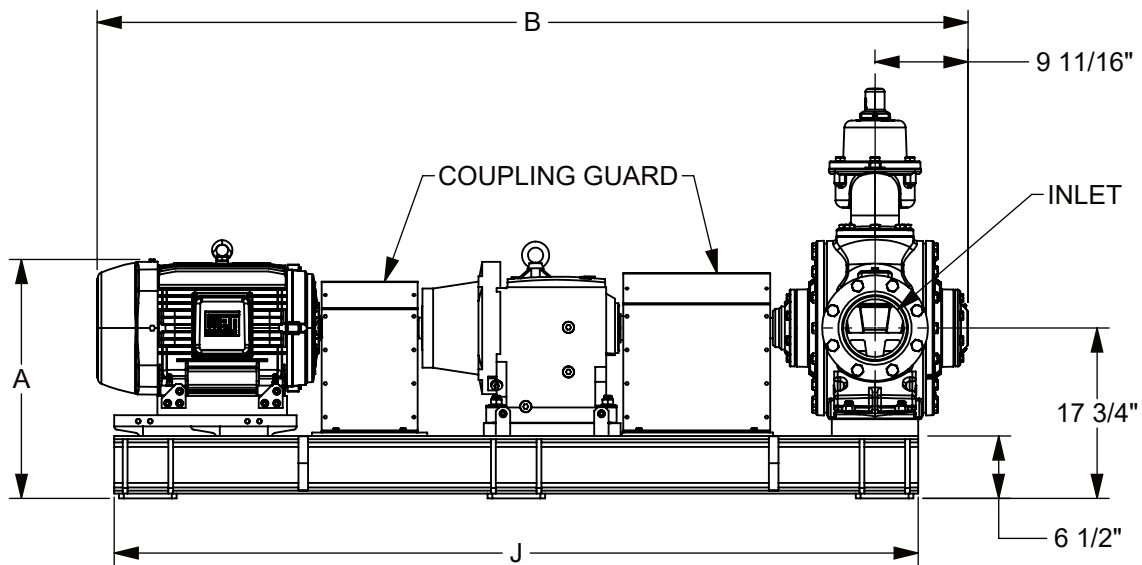
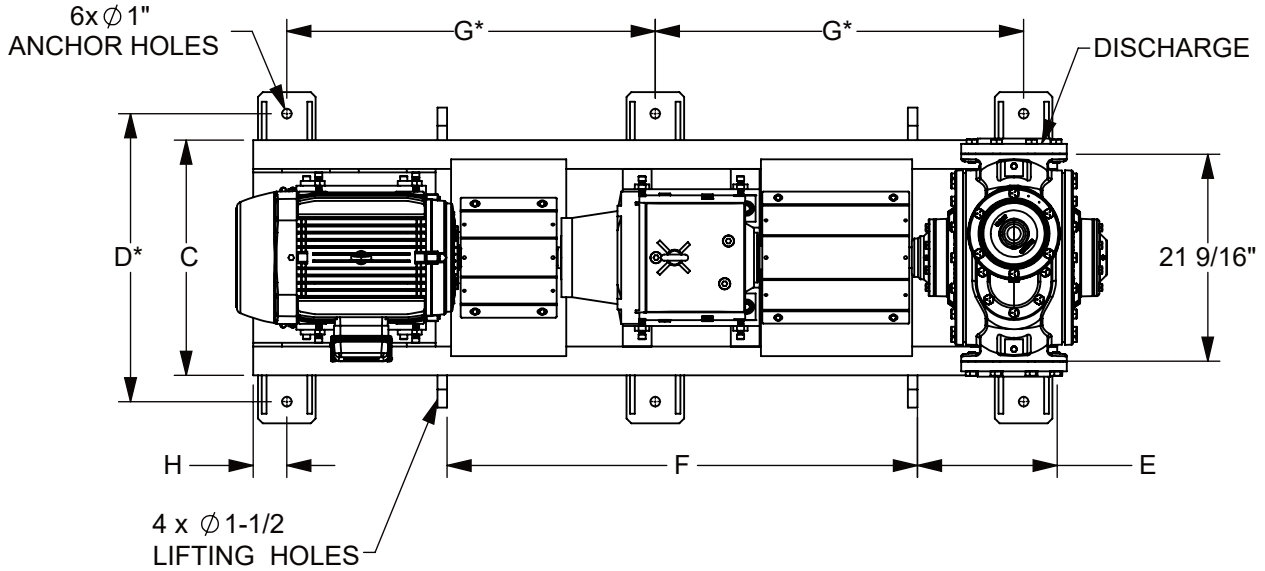

"A" DIMENSION LESS MOTOR EYEBOLT

MOTOR			BASE NO.	DIMENSIONS									APPROX. UNIT WT. - POUNDS	
FRAME SIZE	H.P.	RPM		A	B	C	D	E	F	G	H	J	LESS MOTOR	INCL MOTOR
284T	25	1800	901454	24 7/8	90 3/4	24 1/2	30	14 9/16	49	36 3/8	3 1/2	85 3/4	1941	2316
286T	30	1800	901454	24 7/8	91 3/4	24 1/2	30	14 9/16	49	36 3/8	3 1/2	85 3/4	1941	2335
324T	40	1800	901454	25 3/4	93 5/8	24 1/2	30	14 9/16	49	36 3/8	3 1/2	85 3/4	1941	2430
326T	50	1800	901454	25 3/4	94 5/8	24 1/2	30	14 9/16	49	36 3/8	3 1/2	85 3/4	1941	2454
364T	60	1800	901454	26 3/4	95 3/4	24 1/2	30	14 9/16	49	36 3/8	3 1/2	85 3/4	1941	2783
365T	75	1800	901454	26 3/4	96 3/4	24 1/2	30	14 9/16	49	36 3/8	3 1/2	85 3/4	1941	2825