



TYPE	TYPE	SIZE	UNIT STYLE	DIMENSIONS 102-106	
	HXL	8	SK72	Section Effective Replaces Page 1 / 1	102 SEP 2023 NEW

RIGHT HAND ROTATION SHOWN.

*TOLERANCE $\pm 1/8"$

TOLERANCE ON OTHER DIMENSIONS $\pm 1/4"$

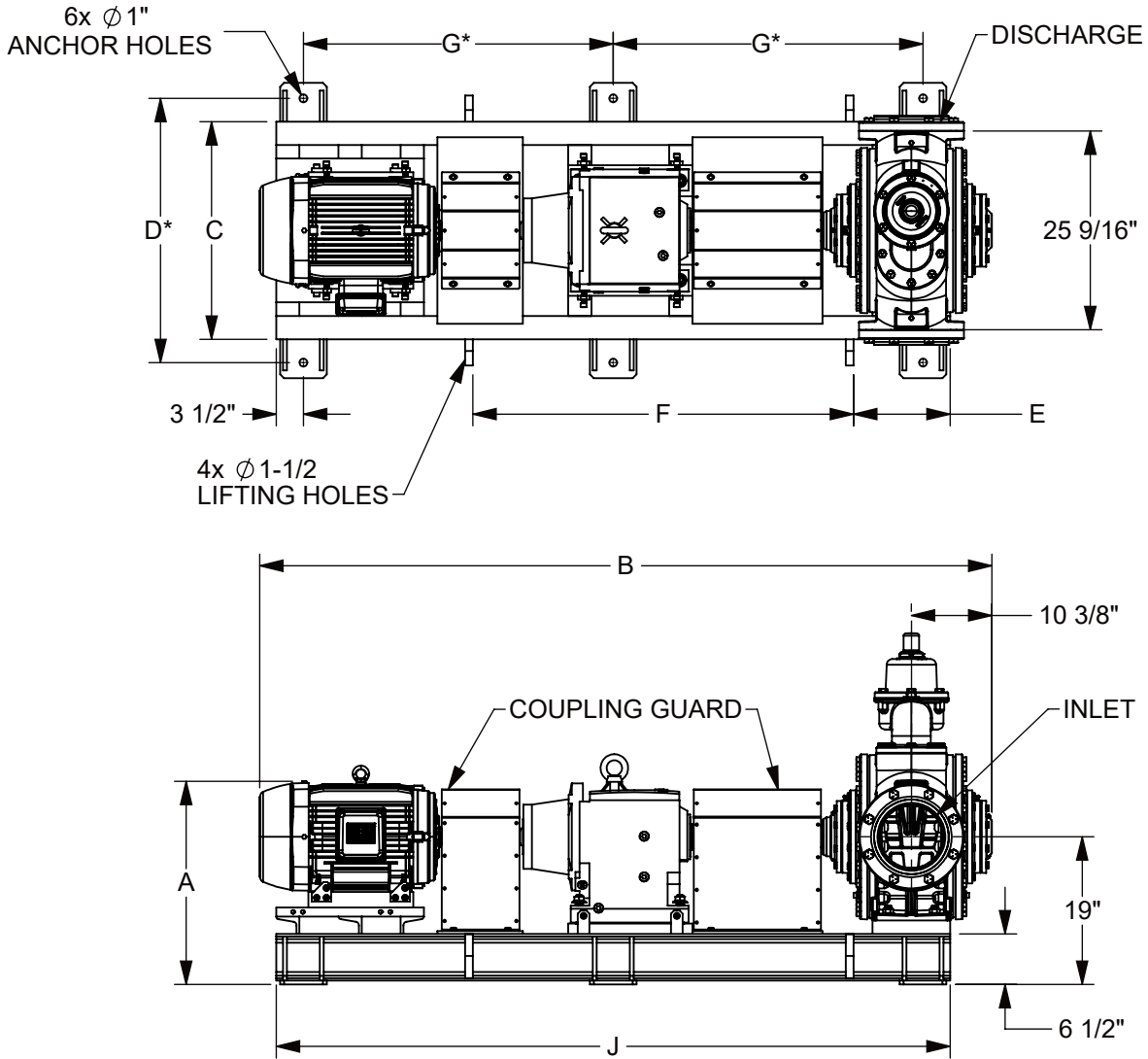

"A" DIMENSION LESS MOTOR EYEBOLT

MOTOR			BASE NO.	DIMENSIONS									APPROX. UNIT WT. - POUNDS	
FRAME SIZE	H.P.	RPM		A	B	C	D	E	F	G	H	J	LESS MOTOR	INCL MOTOR
284T	25	1800	901455	26 1/8	94 1/4	28	34	12 7/16	49	39 7/8	3 1/2	86 3/4	2552	2927
286T	30	1800	901455	26 1/8	95 1/4	28	34	12 7/16	49	39 7/8	3 1/2	86 3/4	2552	2946
324T	40	1800	901455	27	97 1/4	28	34	12 7/16	49	39 7/8	3 1/2	86 3/4	2552	3075
326T	50	1800	901455	27	98 1/4	28	34	12 7/16	49	39 7/8	3 1/2	86 3/4	2552	3101
364T	60	1800	901455	28	99 1/4	28	34	12 7/16	49	39 7/8	3 1/2	86 3/4	2552	3394
365T	75	1800	901455	28	100 1/4	28	34	12 7/16	49	39 7/8	3 1/2	86 3/4	2552	3436