



TYPE	SIZE	UNIT STYLE	DIMENSIONS 102-108	
	HXL	10	SK92	Section Effective Replaces Page 1 / 1

RIGHT HAND ROTATION SHOWN.

\*TOLERANCE  $\pm 1/8"$

TOLERANCE ON OTHER DIMENSIONS  $\pm 1/4"$

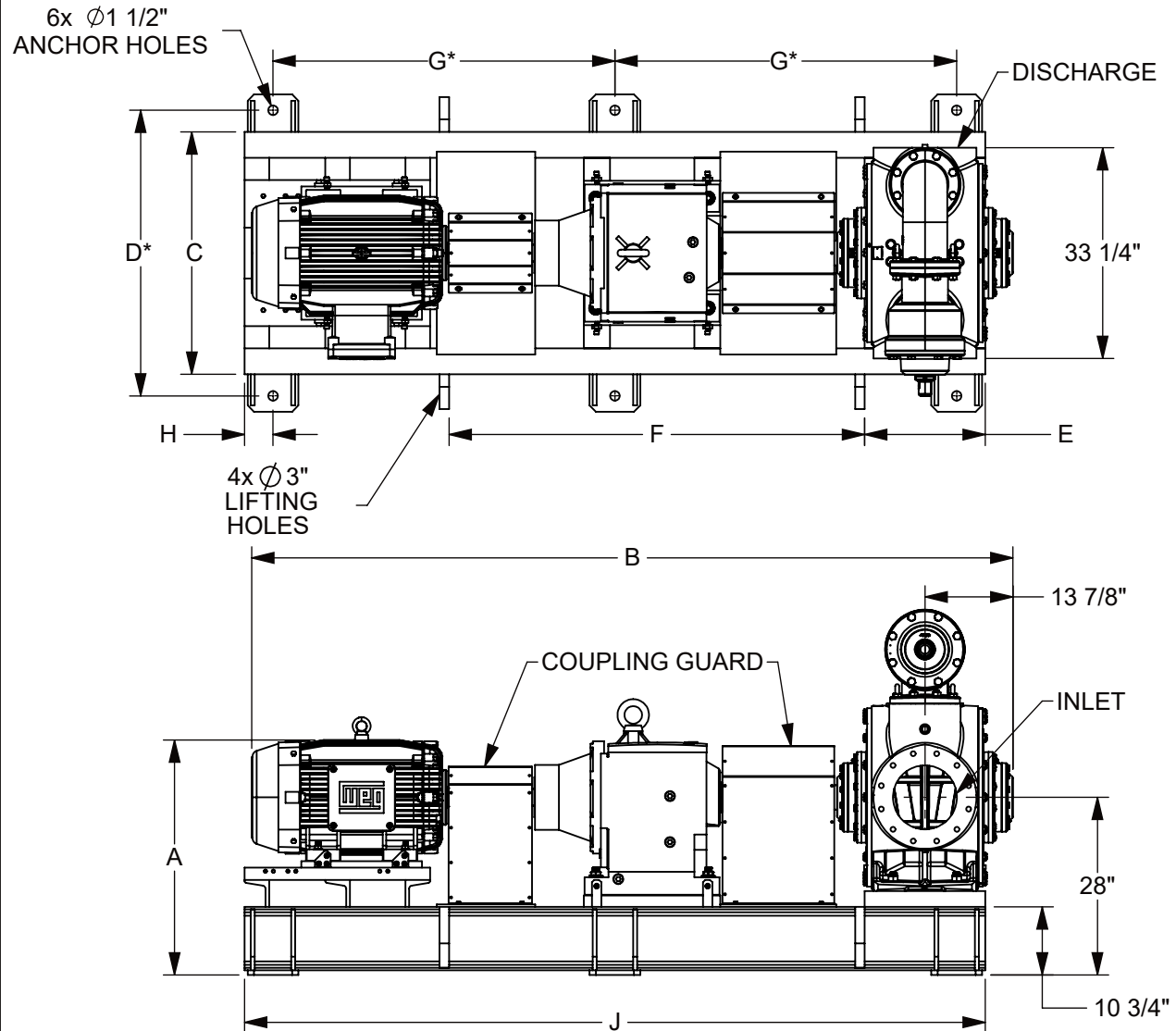

"A" DIMENSION LESS MOTOR EYEBOLT

MOTOR			BASE NO.	DIMENSIONS									APPROX. UNIT WT. - POUNDS	
FRAME SIZE	H.P.	RPM		A	B	C	D	E	F	G	H	J	LESS MOTOR	INCL MOTOR
364T	75	1800	901456	37	116	38 3/16	45	19	65 1/2	53 7/8	4 1/2	116 3/4	6191	6794
365T	100	1800	901456	37	118	38 3/16	45	19	65 1/2	53 7/8	4 1/2	116 3/4	6191	6834
404T	125	1800	901456	37 1/16	120	38 3/16	45	19	65 1/2	53 7/8	4 1/2	116 3/4	6191	7415
405T	150	1800	901456	37 1/16	122	38 3/16	45	19	65 1/2	53 7/8	4 1/2	116 3/4	6191	7486
444T	200	1800	901456	39 1/4	130	38 3/16	45	19	65 1/2	53 7/8	4 1/2	116 3/4	6191	8415
447T	250	1800	901456	39 1/4	132	38 3/16	45	19	65 1/2	53 7/8	4 1/2	116 3/4	6191	8536