



TYPE	SIZE	UNIT STYLE
NPH	4F	PO

DIMENSIONS 103-113	
Section Effective Replaces Page 1 / 4	103 OCT 2023 OCT 2012

RIGHT HAND ROTATION SHOWN. FOR LEFT HAND ROTATION, SHAFT PROJECTION IS OPPOSITE OF VIEW SHOWN.

*TOLERANCE $\pm 1/8"$

TOLERANCE ON OTHER DIMENSIONS $\pm 1/4"$

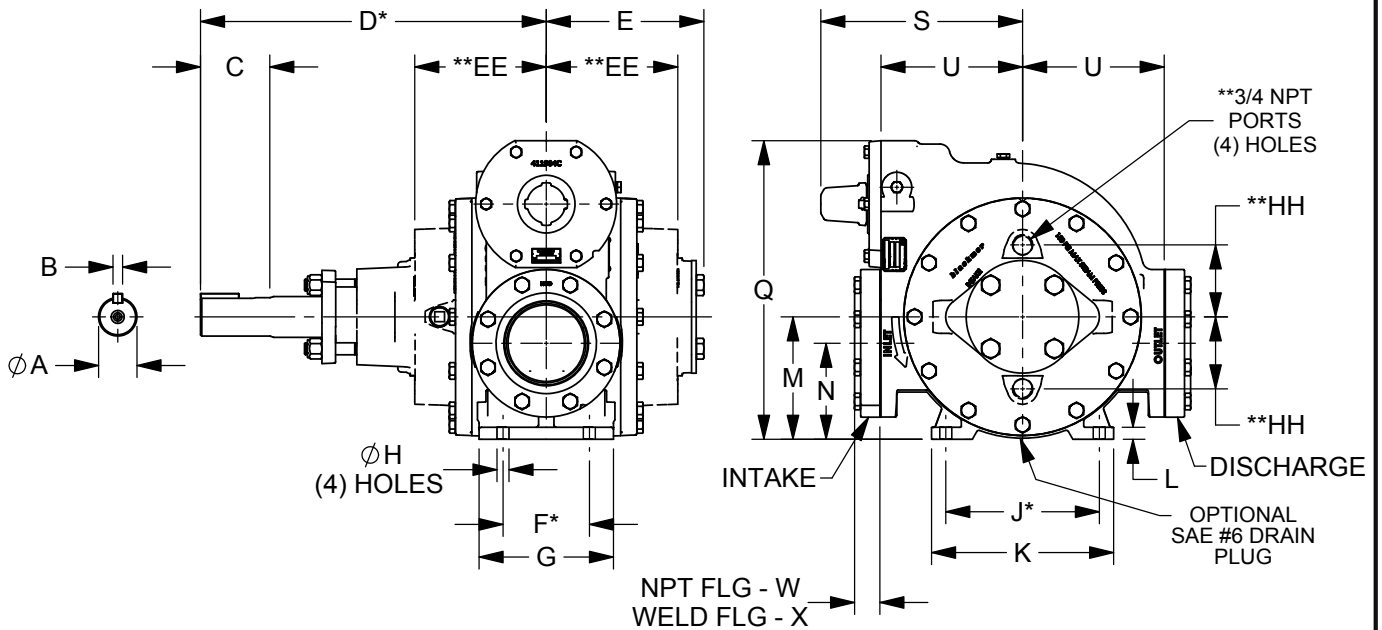

** OPTIONAL STEAM JACKET ONLY

NOTE: FOR ANSI AND DIN FLANGE DIMENSIONS, SEE DIMENSIONS SHEET 103-115.

MOTOR		UNITS	DIMENSIONS									
FRAME SIZE			A	B	C	D	E	F	G	H	J	K
		IN	2	1/2	3 5/8	18	8 1/8	4 1/2	7	5/8	8	9 1/2
		MM	50,8	12,7	92,1	457,2	206,4	114,3	177,8	15,9	203,2	241,3
			L	M	N	P	Q	R	S	T	U	V
		IN	5/8	6 3/8	5	---	15 1/2	---	10 1/2	---	7 3/8	---
		MM	15,9	161,9	127	---	393,7	---	266,7	---	187,3	---
			W	X	Y	Z	AA	BB	CC	DD	EE	FF
		IN	1 5/16	3	---	---	---	---	---	---	6 7/8	---
		MM	33,3	76,2	---	---	---	---	---	---	174,6	---
			GG	HH				PUMP WEIGHT		WITH STD FLANGES	**WITH JACKETED HEADS	
			---	3 3/4				296 LBS		314 LBS	310 LBS	
			---	95,2				134 KG		142 KG	141 KG	



TYPE	SIZE	UNIT STYLE
NP(H)	4F	SK1071

DIMENSIONS 103-113	
Section	103
Effective	OCT 2023
Replaces	NEW
Page	2 / 4

RIGHT HAND ROTATION SHOWN.

*TOLERANCE $\pm 1/8$ "

TOLERANCE ON OTHER DIMENSIONS $\pm 1/4$ "

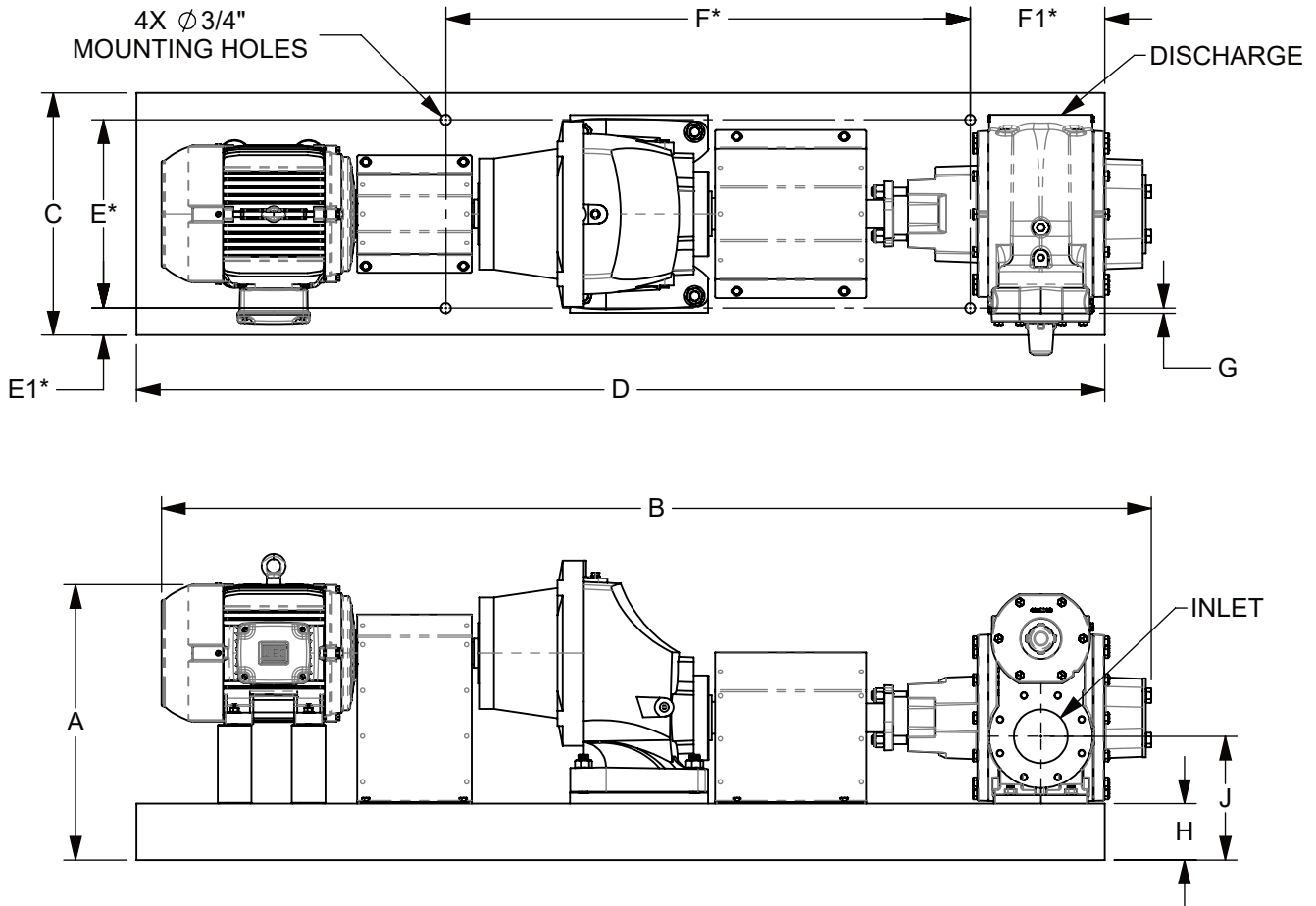

"A" DIMENSION LESS MOTOR EYEBOLT

MOTOR			BASE NO.	DIMENSIONS											APPROX. UNIT WT. - POUNDS	
FRAME SIZE	H.P.	RPM		A	B	C	D	E	E1	F	F1	G	H	J	LESS MOTOR	INCL MOTOR
213T	7 1/2	1800	901439	20 1/2	73 5/8	18	72	14	2	39	10	3/8	4 3/16	9 3/16	961	1119
215T	10	1800	901439	20 1/2	75 1/4	18	72	14	2	39	10	3/8	4 3/16	9 3/16	961	1138
254T	15	1800	901447	21 1/2	78 7/8	18	82	14	2	41	15	3/8	4 3/16	9 3/16	1116	1290
256T	20	1800	901447	21 1/2	80 5/8	18	82	14	2	41	15	3/8	4 3/16	9 3/16	1116	1351
284T	25	1800	901451	22 1/4	82 5/8	18	82	14	2	39	14	3/8	4 3/16	9 3/16	1025	1411
286T	30	1800	901451	22 1/4	84 1/8	18	82	14	2	39	14	3/8	4 3/16	9 3/16	1025	1466
324T	40	1800	901452	23 1/8	85 3/4	18	82	14	2	40	15	3/8	4 3/16	9 3/16	1025	1571
326T	50	1800	901452	23 1/8	87 1/4	18	82	14	2	40	15	3/8	4 3/16	9 3/16	1025	1622



TYPE	SIZE	UNIT STYLE
NPH	4F	HRB

DIMENSIONS 103-113	
Section Effective Replaces Page 3 / 4	103 OCT 2023 OCT 2012

RIGHT HAND ROTATION SHOWN.

*TOLERANCE $\pm 1/8"$

TOLERANCE ON OTHER DIMENSIONS $\pm 1/4"$

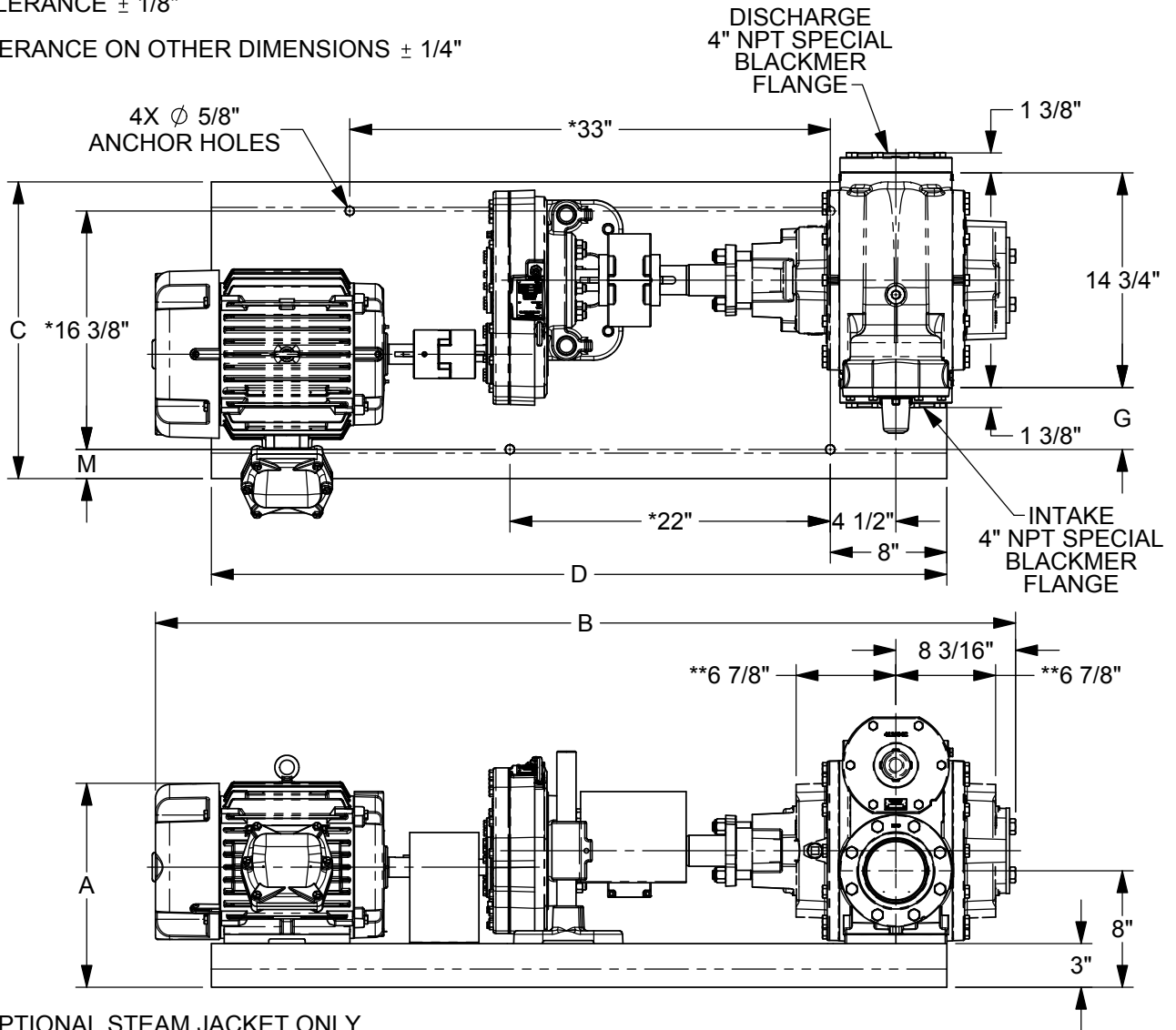

** OPTIONAL STEAM JACKET ONLY

"A" DIMENSION LESS MOTOR EYEBOLT

FRAME SIZE	MOTOR		BASE NO.	DIMENSIONS						APPROX. UNIT WT. - POUNDS	
	H.P.	RPM		A	B	C	D	G	M	LESS MOTOR	ENCL MOTOR
213T	7 1/2	1800	901661	14 1/8	58 1/4	20 3/8	50 1/2	4 1/4	2	650	778
215T	10	1800	901661	14 1/8	59 3/4	20 3/8	50 1/2	4 1/4	2	650	778
254T	15	1800	901662	16 1/8	63 1/4	22	58	5 1/16	2 13/16	695	942
256T	20	1800	901662	16 1/8	65 1/8	22	58	5 1/16	2 13/16	695	964
284T	25	1800	901663	17 5/8	67 1/8	22	58	5 1/16	2 13/16	700	1096
286T	30	1800	901663	17 5/8	68 5/8	22	58	5 1/16	2 13/16	700	1133
324T	30/25	1800/ 1200	901499	19 1/2	69 1/4	24	65	5 7/16	2	760	1306



TYPE	TYPE	SIZE	UNIT STYLE	DIMENSIONS 103-113	
	NPH	4F	HRB	Section Effective Replaces Page 4 / 4	103 OCT 2023 OCT 2012

LEFT HAND ROTATION SHOWN.

*TOLERANCE $\pm 1/8"$

TOLERANCE ON OTHER DIMENSIONS $\pm 1/4"$

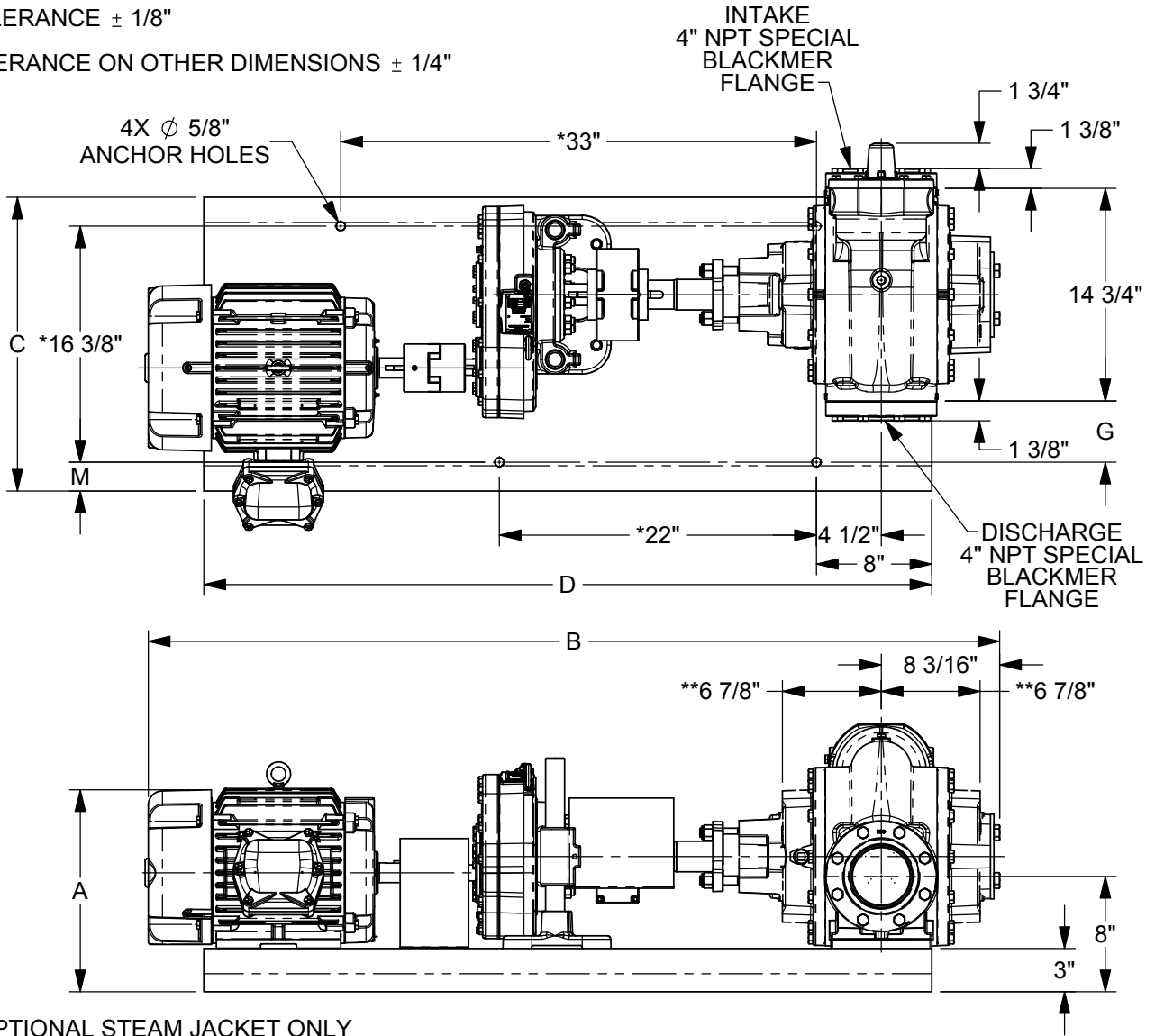

** OPTIONAL STEAM JACKET ONLY

"A" DIMENSION LESS MOTOR EYEBOLT

FRAME SIZE	MOTOR		BASE NO.	DIMENSIONS						APPROX. UNIT WT. - POUNDS		
	H.P.	RPM		A	B	C	D	G	M	LESS MOTOR	ENCL MOTOR	
213T	7 1/2	1800	901661	14 1/8	58 1/4	20 3/8	50 1/2	4 1/4	2		650	778
215T	10	1800	901661	14 1/8	59 3/4	20 3/8	50 1/2	4 1/4	2		650	778
254T	15	1800	901662	16 1/8	63 1/4	22	58	5 1/16	2 13/16		695	942
256T	20	1800	901662	16 1/8	65 1/8	22	58	5 1/16	2 13/16		695	964
284T	25	1800	901663	17 5/8	67 1/8	22	58	5 1/16	2 13/16		700	1096
286T	30	1800	901663	17 5/8	68 5/8	22	58	5 1/16	2 13/16		700	1133
324T	30/25	1800/ 1200	901499	19 1/2	69 1/4	24	65	5 7/16	2		760	1306