

DIMENSIONS 104-105

Section 104
 Effective SEP 2023
 Replaces APR 2003
 Pg 3/3

TYPE

SIZE

UNIT
 STYLE

SNP-SNPJ

2

HRA



www.blackmer.com

RIGHT HAND ROTATION. FOR LEFT HAND ROTATION, INTAKE, DISCHARGE, AND RELIEF VALVE ARE OPPOSITE THAT SHOWN.

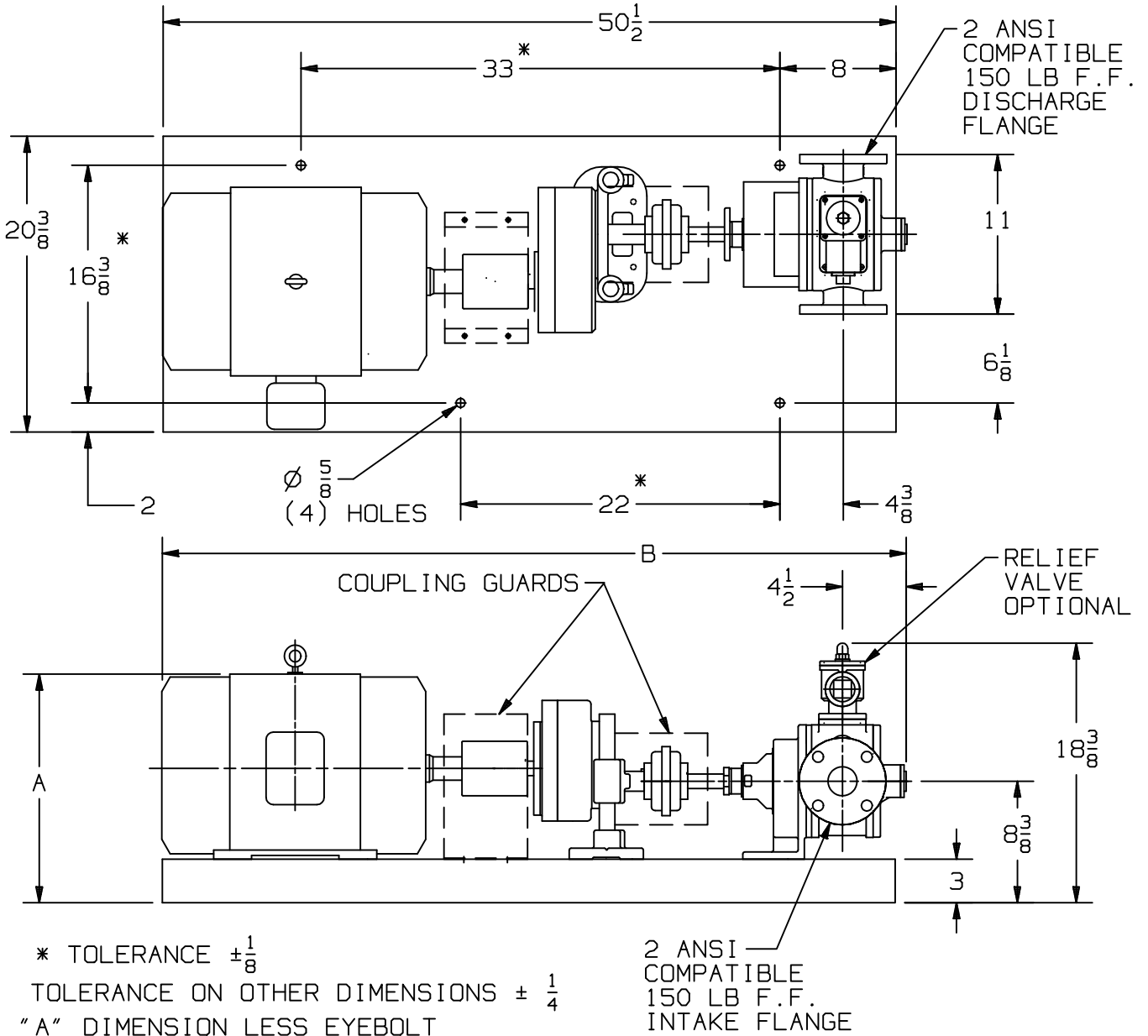

FRAME SIZE	MOTOR	BASE NO.	DIMENSIONS						APPROX. UNIT WT. - POUNDS	
			A	B					LESS MOTOR	INCL. MOTOR
182T		901684	12 5/8	52 1/8						
184T		901684	12 5/8	52 1/8						
213T		901684	14 1/8	52 1/8						
215T		901684	14 1/8	52 1/8						
254T		901684	16 3/8	53 1/2						
256T		901684	16 3/8	55 1/4						