



TYPE	SIZE	UNIT STYLE
MLX	4	SK62

DIMENSIONS 106 - 109	
Section Effective Replaces Page 1 / 1	106 SEP 2023 NEW

RIGHT HAND ROTATION SHOWN.

*TOLERANCE $\pm 1/8$ "

TOLERANCE ON OTHER DIMENSIONS $\pm 1/4$ "

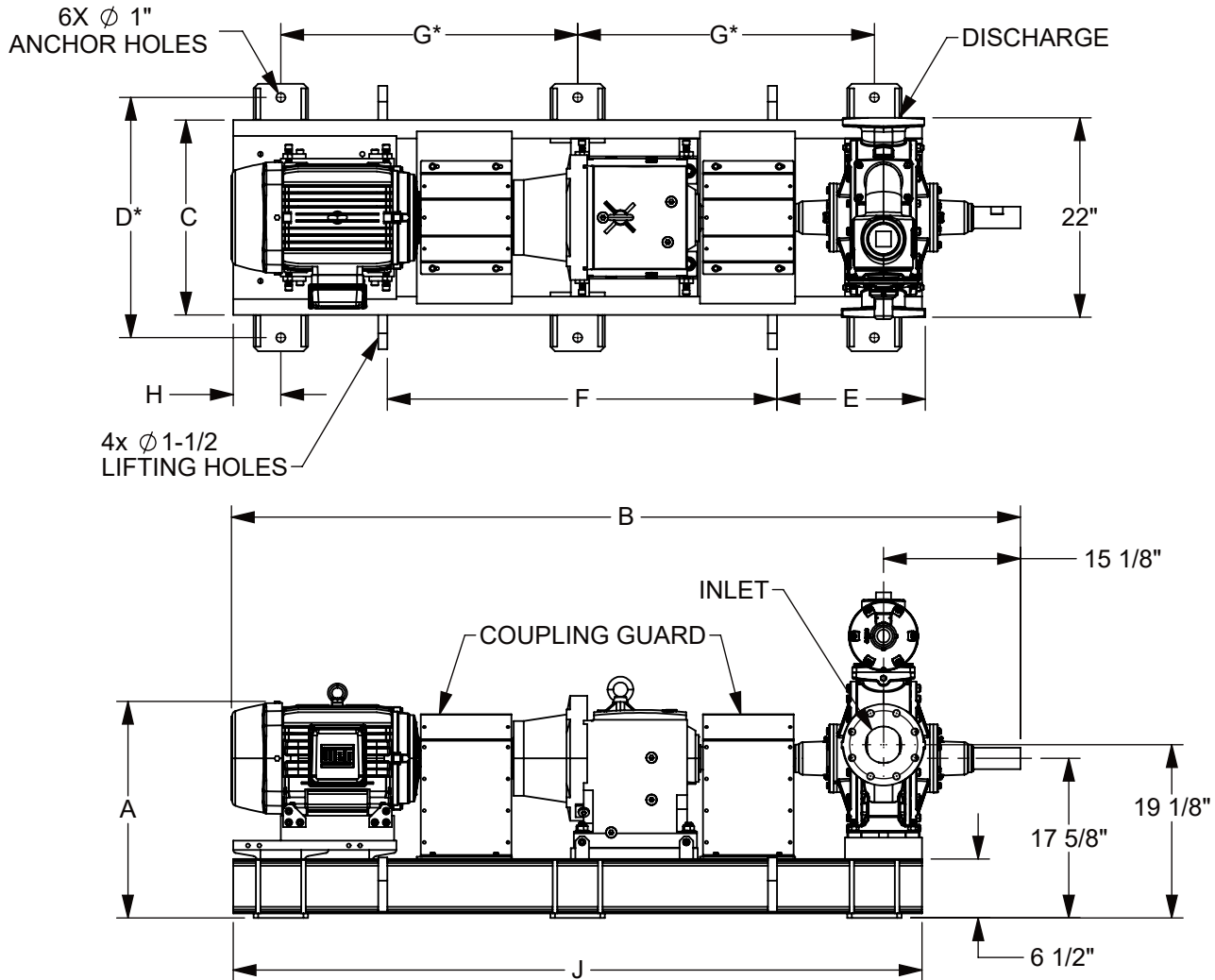

"A" DIMENSION LESS MOTOR EYEBOLT

MOTOR			BASE NO.	DIMENSIONS									APPROX. UNIT WT. - POUNDS	
FRAME SIZE	H.P.	RPM		A	B	C	D	E	F	G	H	J	LESS MOTOR	INCL MOTOR
254T	15	1800	901453	23 15/16	86 1/16	21 1/2	26 1/2	16 3/8	43	32 3/4	5 1/4	76	1380	1600
256T	20	1800	901453	23 15/16	87 1/16	21 1/2	26 1/2	16 3/8	43	32 3/4	5 1/4	76	1380	1630
284T	25	1800	901453	24 3/4	88 1/4	21 1/2	26 1/2	16 3/8	43	32 3/4	5 1/4	76	1380	1760
286T	30	1800	901453	24 3/4	89 1/4	21 1/2	26 1/2	16 3/8	43	32 3/4	5 1/4	76	1380	1790
324T	40	1800	901453	25 3/5	91 5/16	21 1/2	26 1/2	16 3/8	43	32 3/4	5 1/4	76	1380	1840
326T	50	1800	901453	25 3/5	92 5/16	21 1/2	26 1/2	16 3/8	43	32 3/4	5 1/4	76	1380	1900
364T	60	1800	901453	37 15/16	94 3/4	21 1/2	26 1/2	16 3/8	43	32 3/4	5 1/4	76	1380	2180
365T	75	1800	901453	37 15/16	94 3/4	21 1/2	26 1/2	16 3/8	43	32 3/4	5 1/4	76	1380	2240