



TYPE	XL	SIZE	4	UNIT STYLE	SK52W	DIMENSIONS 107-109	
						Section Effective Replaces Page 2 / 7	107 SEPTEMBER 2023 NEW

RIGHT HAND ROTATION SHOWN.

*TOLERANCE $\pm 1/8$ "

TOLERANCE ON OTHER DIMENSIONS $\pm 1/4$ "

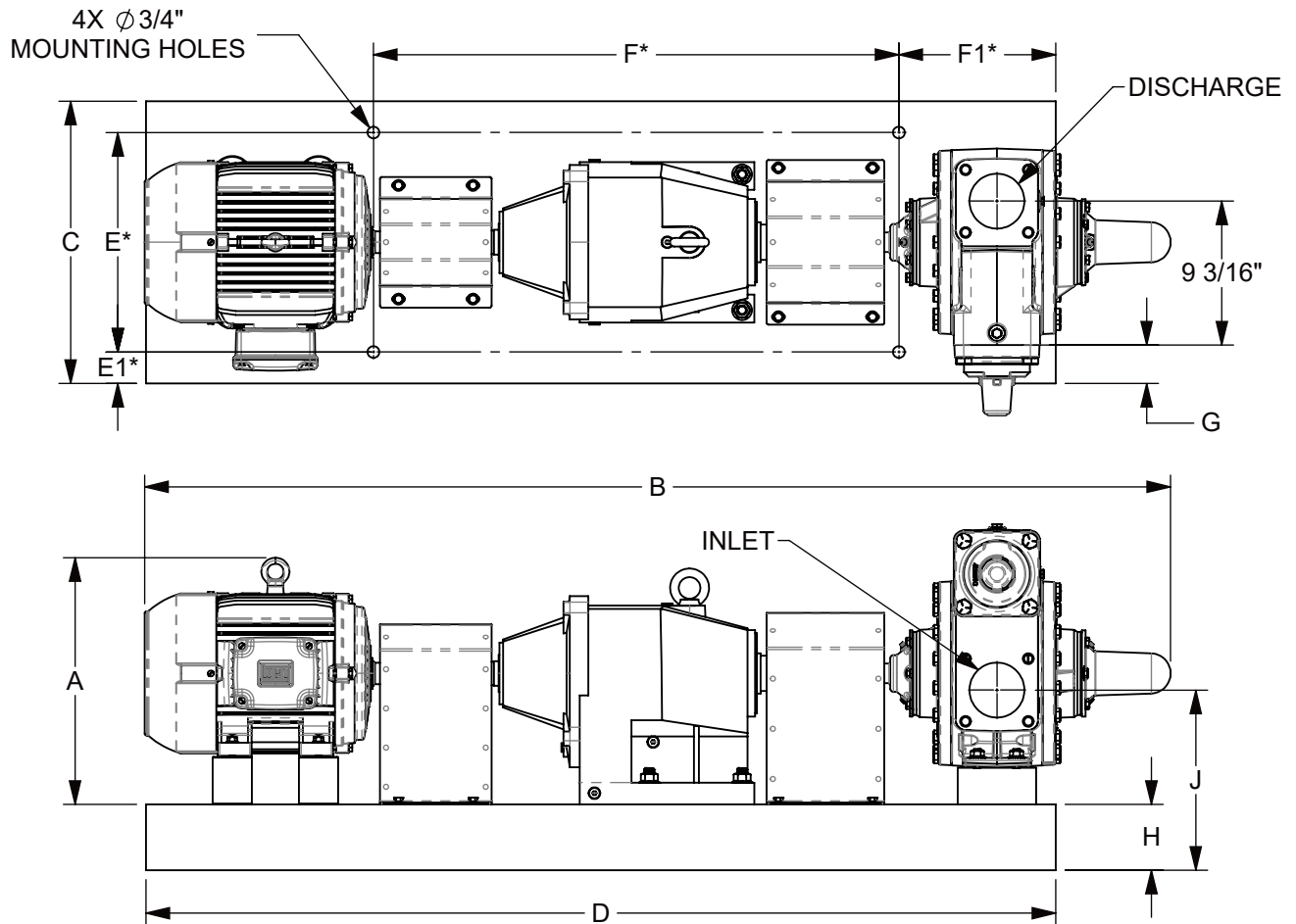

"A" DIMENSION LESS MOTOR EYEBOLT

MOTOR			BASE NO.	DIMENSIONS											APPROX. UNIT WT. - POUNDS	
FRAME SIZE	H.P.	RPM		A	B	C	D	E	E1	F	F1	G	H	J	LESS MOTOR	INCL. MOTOR
213T	7 1/2	1800	901461	15 3/4	65 3/8	18	58	14	2	33 1/2	10	2 1/2	4 1/4	11 1/2	848	1006
215T	10	1800	901461	15 3/4	66 7/8	18	58	14	2	33 1/2	10	2 1/2	4 1/4	11 1/2	848	1025
254T	15	1800	901463	16 5/8	70 3/4	18	64	14	2	32 1/2	12	2 1/2	4 1/4	11 1/2	876	1150
256T	20	1800	901463	16 5/8	72 1/2	18	64	14	2	32 1/2	12	2 1/2	4 1/4	11 1/2	876	1211
284T	25	1800	901464	17 1/2	73 5/8	18	64	15	1 1/2	30	14	2 1/2	4 1/4	11 1/2	877	1263
286T	30	1800	901464	17 1/2	75 1/8	18	64	15	1 1/2	30	14	2 1/2	4 1/4	11 1/2	877	1318

