



TYPE	SIZE	UNIT STYLE	DIMENSIONS 201-109	
TX	4A	PO	Section Effective Replaces Page 1 / 1	201 FEB 2023 APR 2022

RIGHT HAND ROTATION. FOR LEFT HAND ROTATION, SHAFT PROJECTION IS OPPOSITE THAT SHOWN.

*TOLERANCE $\pm 1/8"$

TOLERANCE ON OTHER DIMENSIONS $\pm 1/4"$

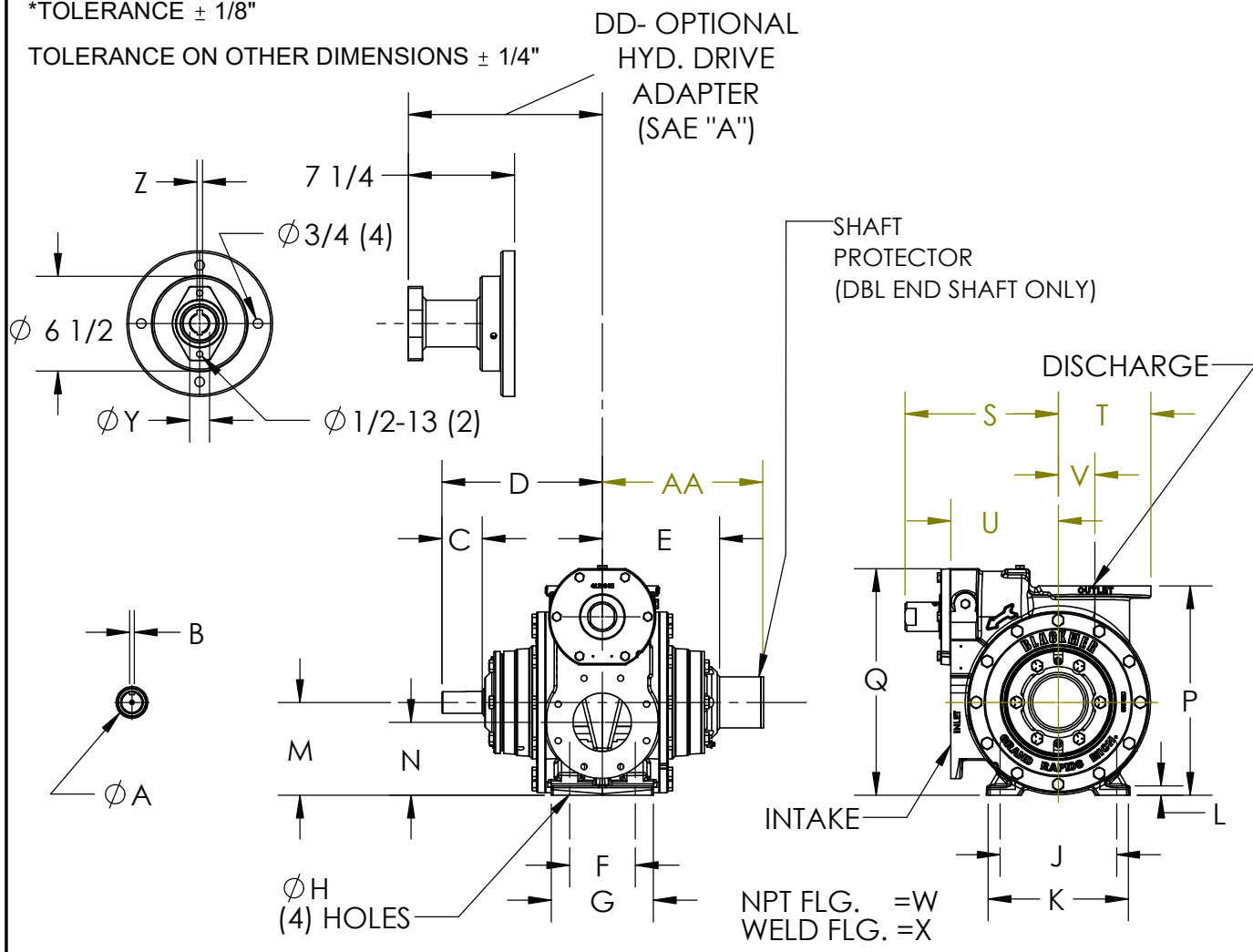

DIMENSIONS											WEIGHTS	
UNITS	A	B	C	D	E	F	G	H	J	K	UNITS	PUMP ONLY
IN	1 1/2	3/8	2 7/8	11	8 1/4	4 1/2	7	5/8	8	9 1/2	LBS	295
MM	38.10	9.53	73.03	279.40	209.55	114.30	177.80	15.88	203.20	241.30	KG	134
	L	M	N	P	Q	R	S	T	U	V		NPT FLANGES
IN	5/8	6 3/8	5	14 3/8	15 1/2	---	10 1/2	6 3/8	7 3/8	2 1/2	LBS	311
MM	15.88	161.93	127.00	365.13	393.70	---	266.70	161.93	187.33	63.50	KG	141
	W	X	Y	Z	AA	BB	CC	DD	EE	FF		WELD FLANGES
IN	1 3/8	3	1 1/4	3/8	11 5/8	---	---	13 7/16	---	---	LBS	318
MM	34.93	76.20	31.75	9.52	295.28	---	---	341.31	---	---	KG	144
	GG	HH	JJ	KK	LL	MM						
IN	---	---	---	---	---	---						
MM	---	---	---	---	---	---						