



TYPE	SIZE	UNIT STYLE
LGL LGLD3	3	PO

DIMENSIONS 501-113	
Section Effective Replaces Page 1 / 5	501 September 2023 May 2020

RIGHT HAND ROTATION. FOR LEFT HAND ROTATION, SHAFT PROJECTION IS OPPOSITE THAT SHOWN.

*TOLERANCE $\pm 1/8"$

TOLERANCE ON OTHER DIMENSIONS $\pm 1/4"$

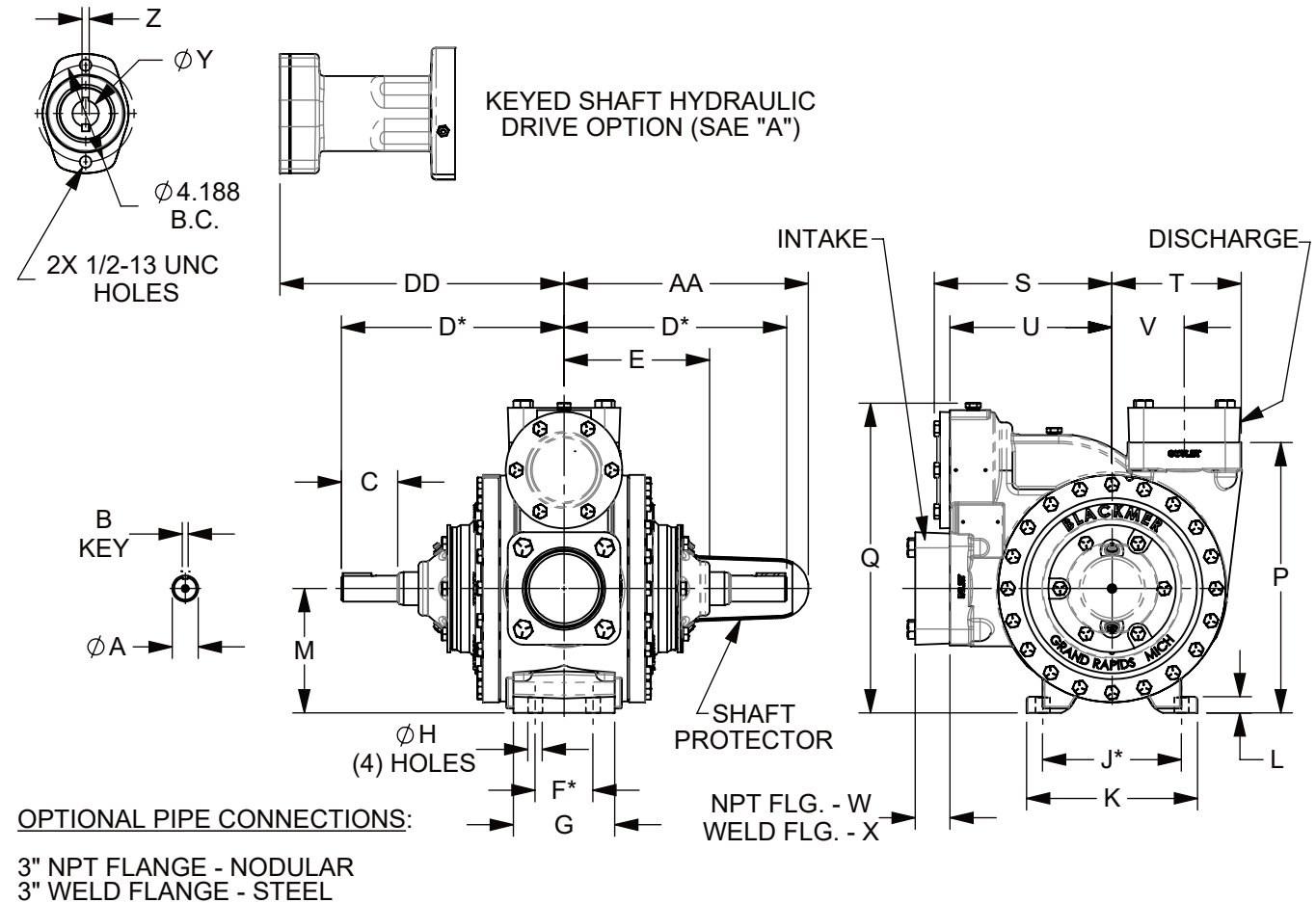

DIMENSIONS											WEIGHTS		
UNITS	A	B	C	D	E	F	G	H	J	K	UNITS	PUMP ONLY	
												LGL3	LGLD3
IN	1 1/8	1/4	2 7/16	9 5/8	6 5/16	2 1/2	4 3/8	5/8	6	7 3/8	LBS	121	123
MM	28,6	6,4	61,9	244,5	160,3	63,5	111,1	15,9	152,4	187,3	KG	55	56
	L	M	N	P	Q	R	S	T	U	V		NPT FLGS	
												LGL3	LGLD3
IN	1/2	5 3/8	---	11 11/16	13 3/8	---	7 5/8	5 5/8	7	3 1/8	LBS	131	133
MM	12,7	136,5	---	269,9	339,7	---	193,7	142,9	177,8	79,4	KG	59	60
	W	X	Y	Z	AA	BB	CC	DD	EE	FF		WELD FLGS	
												LGL3	LGLD3
IN	1 1/2	1 3/16	1 1/4	5/16	10 9/16	---	---	12 1/4	---	---	LBS	128	130
MM	38,1	30,2	31,8	7,9	268,3	---	---	311,2	---	---	KG	58	59
	GG	HH	JJ	KK	LL	MM						HYD DRIVE NO FLANGES	
												LGL3	LGLD3
IN	---	---	---	---	---	---					LBS	138	140
MM	---	---	---	---	---	---					KG	63	64



TYPE	SIZE	UNIT STYLE
LGL LGLD3	3	VB

DIMENSIONS 501-113	
Section Effective Replaces Page 3 / 5	501 September 2023 May 2020

RIGHT HAND ROTATION SHOWN.

*TOLERANCE $\pm 1/8"$

TOLERANCE ON OTHER DIMENSIONS $\pm 1/4"$

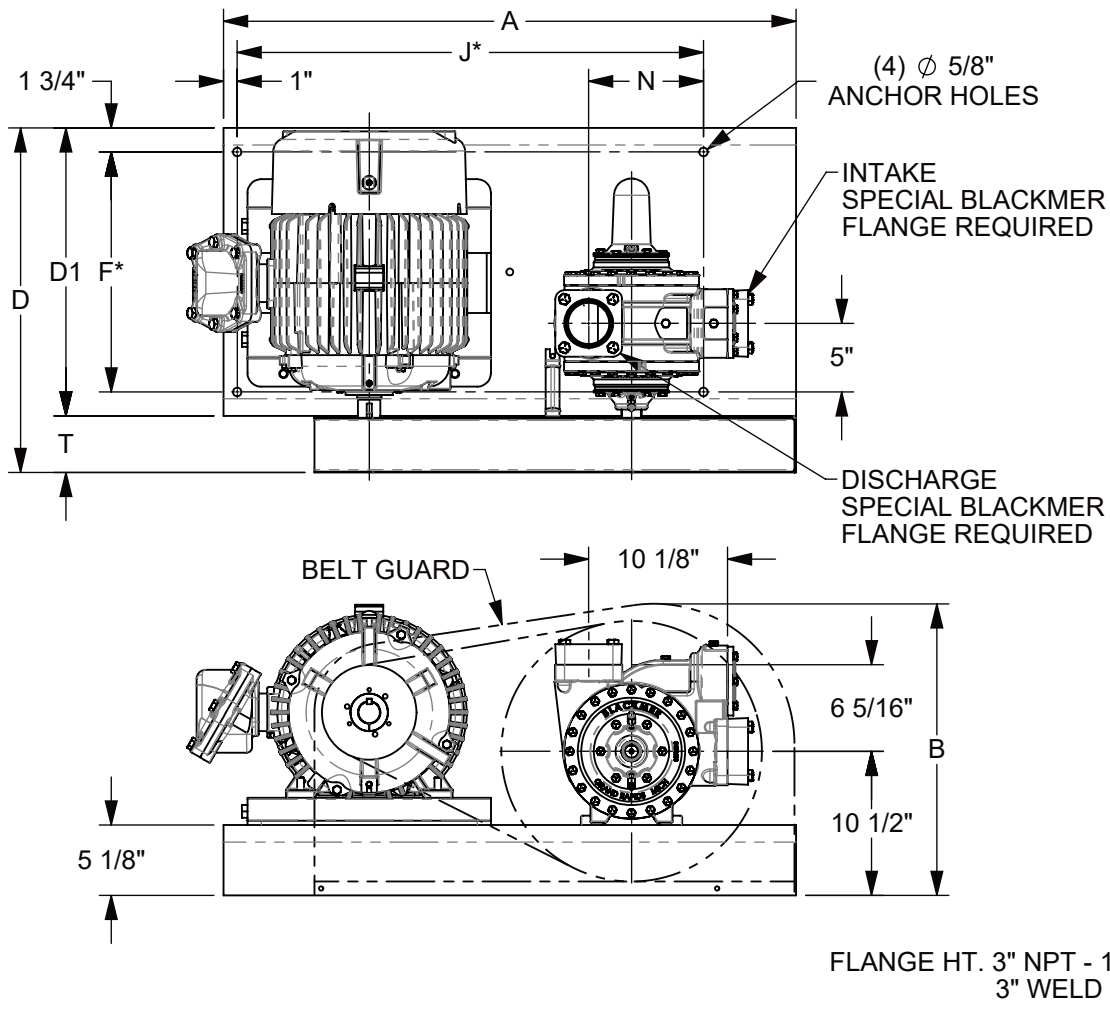

MOTOR				DIMENSIONS												APPROX. UNIT WT. - POUNDS	
FRAME SIZE	SPEED 1750/1450	H.P.	BASE NO.	A	B	D	D1	F	J	N	T					LESS MOTOR	INCL MOTOR
184T	330/275	5/3	901942	36 7/8	21	19 3/8	15 1/2	12	28	6 1/8	3 7/8	---	---	---	---	302	507
213T	410/340	7.5/5	901942	36 7/8	21	19 3/8	15 1/2	12	28	6 1/8	3 7/8	---	---	---	---	307	537
213T	515/425	7.5/5	901942	36 7/8	21	19 3/8	15 1/2	12	28	6 1/8	3 7/8	---	---	---	---	307	537
215T	410/340	10/7.5	901942	36 7/8	21	19 3/8	15 1/2	12	28	6 1/8	3 7/8	---	---	---	---	307	527
215T	515/425	10/7.5	901942	36 7/8	21	19 3/8	15 1/2	12	28	6 1/8	3 7/8	---	---	---	---	307	527
215T	630/525	10/7.5	901942	36 7/8	21	19 3/8	15 1/2	12	28	6 1/8	3 7/8	---	---	---	---	307	527
215T	780/520	10/5	901942	36 7/8	21	19 3/8	15 1/2	12	28	6 1/8	3 7/8	---	---	---	---	307	527
254T	630/525	15/10	901943	41 3/4	21 1/4	25 1/8	21	17 1/2	34	8 3/8	4 1/8	---	---	---	---	354	739
254T	990/825	15/10	901943	41 3/4	21 1/4	25 1/8	21	17 1/2	34	8 3/8	4 1/8	---	---	---	---	354	739
256T	795/660	20/15	901943	41 3/4	21 1/4	25 1/8	21	17 1/2	34	8 3/8	4 1/8	---	---	---	---	354	763

