



TYPE	SIZE	UNIT STYLE
TLGLF	3HD	PO

DIMENSIONS 501-118	
Section Effective Replaces Page 1 / 1	501 DECEMBER 2020 NEW

RIGHT HAND ROTATION. FOR LEFT HAND ROTATION, SHAFT PROJECTION IS OPPOSITE THAT SHOWN.

*TOLERANCE $\pm 1/8"$

TOLERANCE ON OTHER DIMENSIONS $\pm 1/4"$

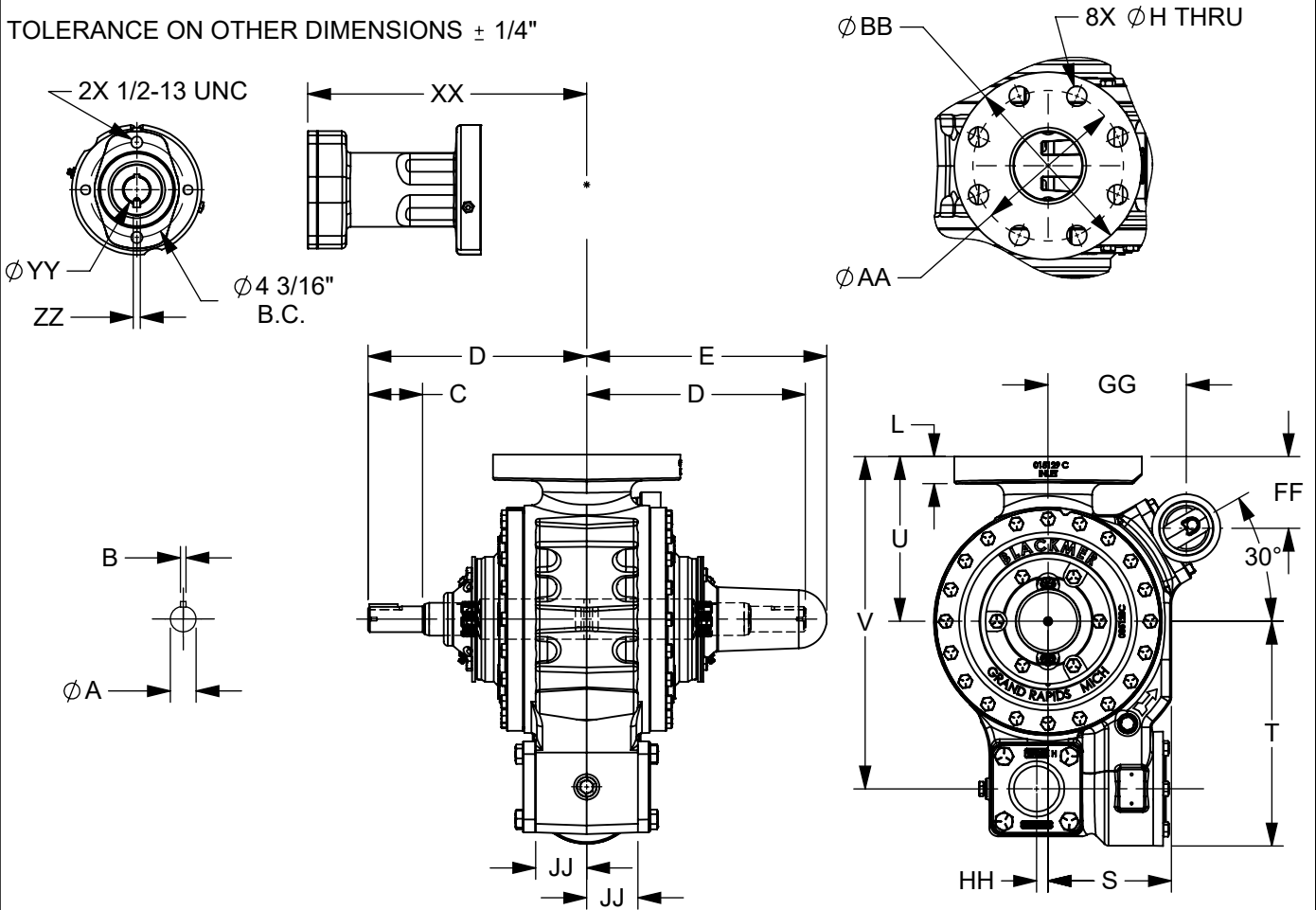

DIMENSIONS											WEIGHTS	
UNITS	A	B	C	D	E	F	G	H	J	K	UNITS	PUMP ONLY
IN	1 1/8	1/4	2 3/8	9 5/8	10 9/16	---	---	7/8	---	---	LBS	149
MM	28.6	6.4	60.3	244	268	---	---	22.2	---	---	KG	68
	L	M	N	P	Q	R	S	T	U	V		
IN	1 3/16	---	---	---	---	---	5 7/16	9 7/8	7 1/4	14 5/8		
MM	30.2	---	---	---	---	---	138	251	184	371		
	W	X	Y	Z	AA	BB	CC	DD	EE	FF		
IN	---	---	---	---	6 5/8	8 1/4	---	---	---	3 3/16		
MM	---	---	---	---	168	210	---	---	---	81		
	GG	HH	JJ	XX	YY	ZZ						
IN	6 1/16	1/2	2 1/4	12 1/4	1 1/4	5/16						
MM	154	12.7	57.2	311	31.8	8						