

TYPE	SIZE	UNIT STYLE
CRL	3	VB

DIMENSIONS 701-107	
Section	701
Effective	SEPTEMBER 2023
Replaces	AUGUST 2002
Page	3 / 5

RIGHT HAND ROTATION

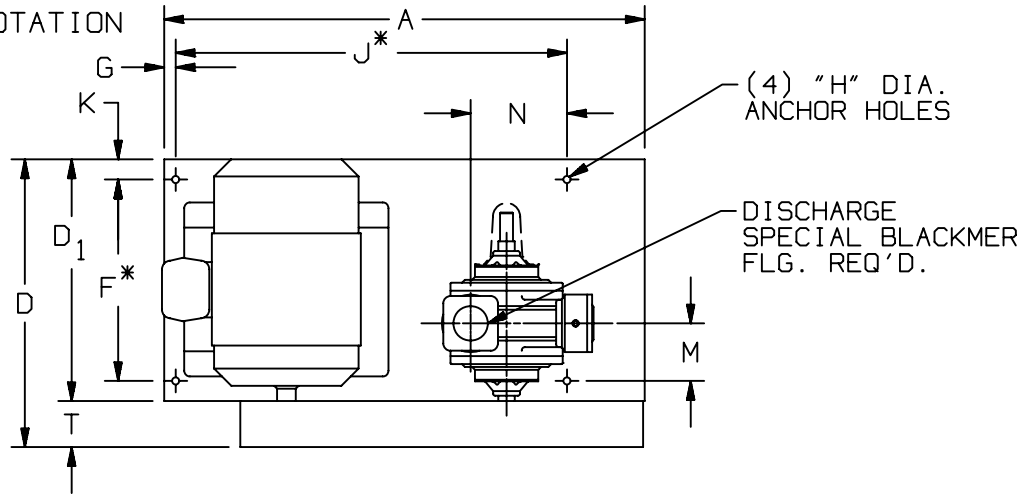

BELT GUARD

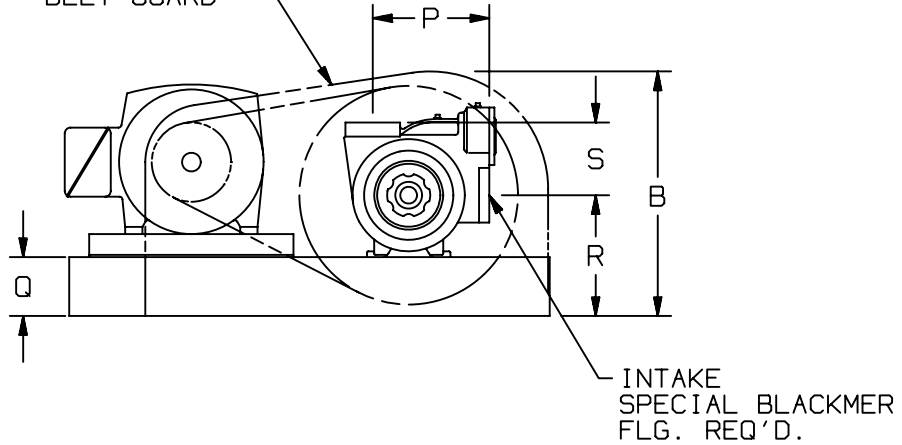

FLANGE	UNIT	HGT.
3" NPT	IN	1 1/2
	MM	38,1
3" WELD	IN	1 3/16
	MM	30,2

UNIT DIMENSIONS LESS FLANGES

* TOLERANCE ±1/8

TOLERANCE ON OTHER DIMENSIONS ±1/4

SPEED		H.P.		UNIT NO.	DIMENSIONS																	
1800	1200	FRAME SIZE	1800		1200	UNIT	A	B	D	D ₁	F	G	H	J	K	M	N	P	Q	R	S	T
330	220	184T	5	2	875115	IN	36 7/8	21 1/2	21 3/8	15 1/2	12	1	5/8	28	1 3/4	5	6 1/8	10 1/8	5 1/8	10 1/2	6 5/16	3 7/8
						MM	936,6	546,1	542,9	393,7	304,8	25,4	15,9	711,2	44,5	127	155,6	257,2	130,2	266,7	160,3	98,4
420	280	213T	7.5	3	875116	IN	—	21 1/2	—	—	—	—	—	—	—	—	—	—	—	—	—	—
						MM	—	546,1	—	—	—	—	—	—	—	—	—	—	—	—	—	—
420	280	215T	10	5	875186	IN	—	21 1/2	—	—	—	—	—	—	—	—	—	—	—	—	—	—
						MM	—	546,1	—	—	—	—	—	—	—	—	—	—	—	—	—	—
520	340	213T	7.5	3	875119	IN	—	21 1/2	—	—	—	—	—	—	—	—	—	—	—	—	—	—
						MM	—	546,1	—	—	—	—	—	—	—	—	—	—	—	—	—	—
520	340	215T	10	5	875117	IN	—	21 1/2	—	—	—	—	—	—	—	—	—	—	—	—	—	—
						MM	—	546,1	—	—	—	—	—	—	—	—	—	—	—	—	—	—
640	420	215T	10	5	875118	IN	—	21 1/2	—	—	—	—	—	—	—	—	—	—	—	—	—	—
						MM	—	546,1	—	—	—	—	—	—	—	—	—	—	—	—	—	—
640	420	254T	15	7.5	875188	IN	41 3/4	21 3/4	25 5/8	21	17 1/2	1	5/8	34	1 3/4	5	8 3/8	10 1/8	5 1/8	10 1/2	6 5/16	4 1/8
						MM	1060,4	552,4	650,9	533,4	444,5	25,4	15,9	863,6	44,5	127	212,7	257	130	266,7	160,3	104,8

SAME AS ABOVE

DIMENSIONS 701 - 107

Section 701
Effective SEPTEMBER 2023
Replaces AUGUST 2002
Page 4 / 5

TYPE

SIZE

UNIT
STYLE

CRL

3

HRA



RIGHT HAND ROTATION

(4) $\varnothing \frac{5}{8}$ ANCHOR HOLES

DISCHARGE
SPECIAL
BLACKMER
FLG. REQD.

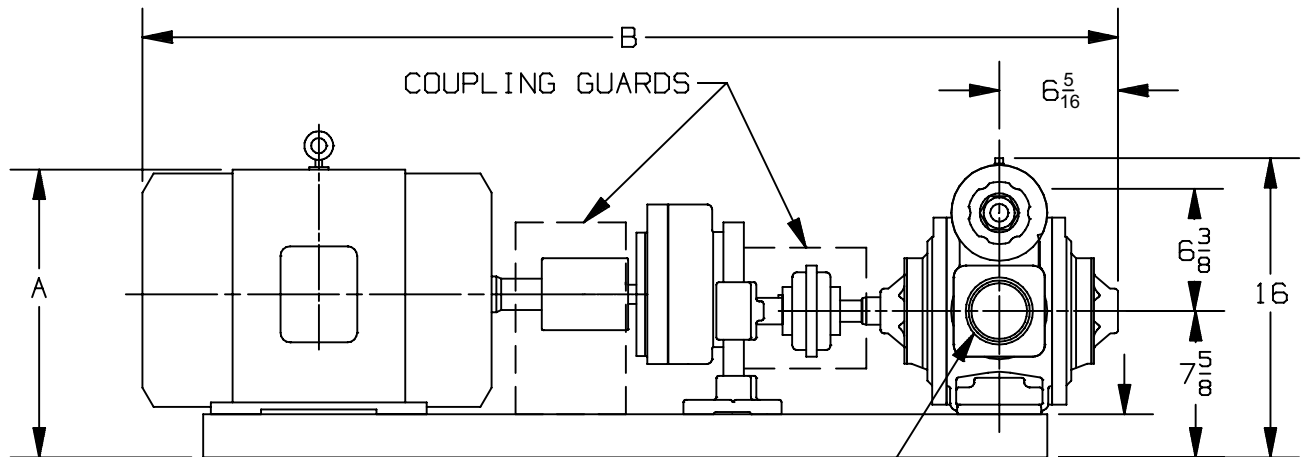
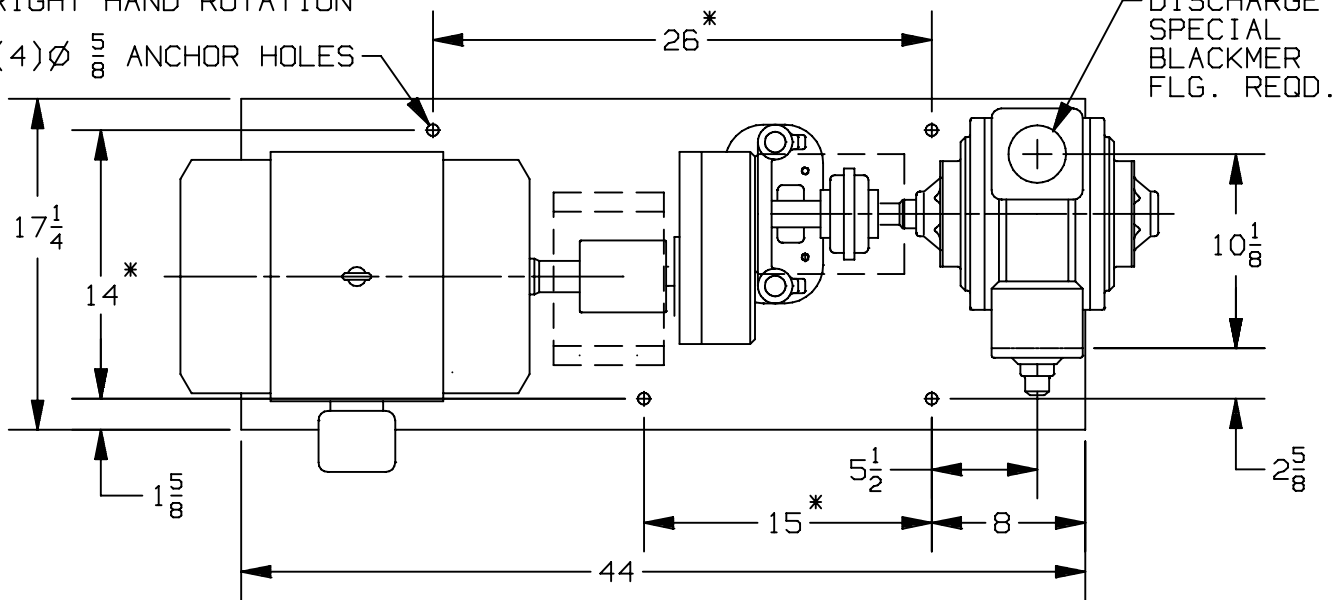

INTAKE
SPECIAL BLACKMER
FLG. REQD

UNIT DIMENSION LESS FLANGES

* TOLERANCE $\pm \frac{1}{8}$

TOLERANCE ON OTHER DIMENSIONS $\pm \frac{1}{4}$

"A" DIMENSION LESS EYEBOLT

FLG. HT: 3" NPT - 1 1/2
3" WELD- 1 1/4

MOTOR			DIMENSIONS			
FRAME SIZE		BASE NO.	UNITS	A	B	
182T		901774	IN	11 7/8	48 3/4	
184T		901774	IN	11 7/8	48 3/4	
213T		901774	IN	13 3/8	48 3/4	
215T		901774	IN	13 3/8	49 3/8	
254T		901774	IN	15 5/8	53 1/4	
256T		901774	IN	15 5/8	55	

DIMENSIONS 701 - 107

Section 701
 Effective SEPTEMBER 2023
 Replaces AUGUST 2002
 Page 5 / 5

TYPE

SIZE

UNIT
 STYLE

CRL

3

HRA



www.blackmer.com

LEFT HAND ROTATION

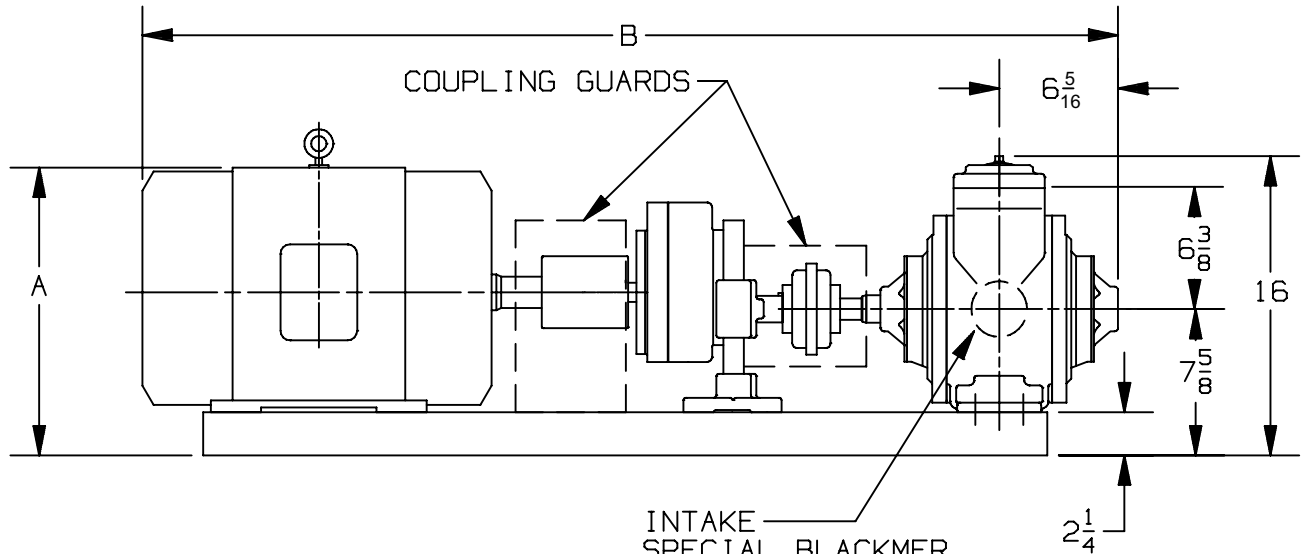
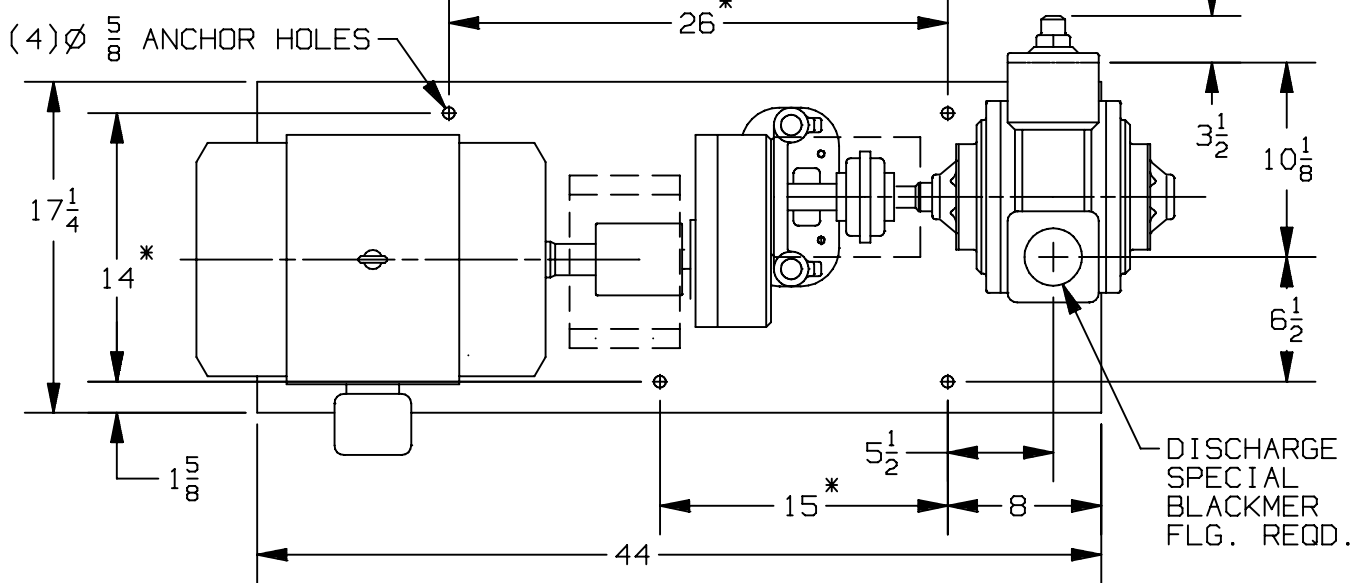

UNIT DIMENSION LESS FLANGES

* TOLERANCE $\pm \frac{1}{8}$

TOLERANCE ON OTHER DIMENSIONS $\pm \frac{1}{4}$

"A" DIMENSION LESS EYEBOLT

FLG. HT: 3" NPT - 1 1/2
 3" WELD- 1 1/4

MOTOR			DIMENSIONS			
FRAME SIZE		BASE NO.	UNITS	A	B	
182T		901774	IN	11 7/8	48 3/4	
184T		901774	IN	11 7/8	48 3/4	
213T		901774	IN	13 3/8	48 3/4	
215T		901774	IN	13 3/8	49 3/8	
254T		901774	IN	15 5/8	53 1/4	
256T		901774	IN	15 5/8	55	