



TYPE	SIZE	UNIT STYLE	DIMENSIONS 801-102	
SGL	2	PO	Section Effective Replaces Page 1 / 5	801 SEPTEMBER 2023 JUNE 2018

RIGHT HAND ROTATION. FOR LEFT HAND ROTATION, SHAFT PROJECTION IS OPPOSITE THAT SHOWN.

*TOLERANCE $\pm 1/8"$

TOLERANCE ON OTHER DIMENSIONS $\pm 1/4"$

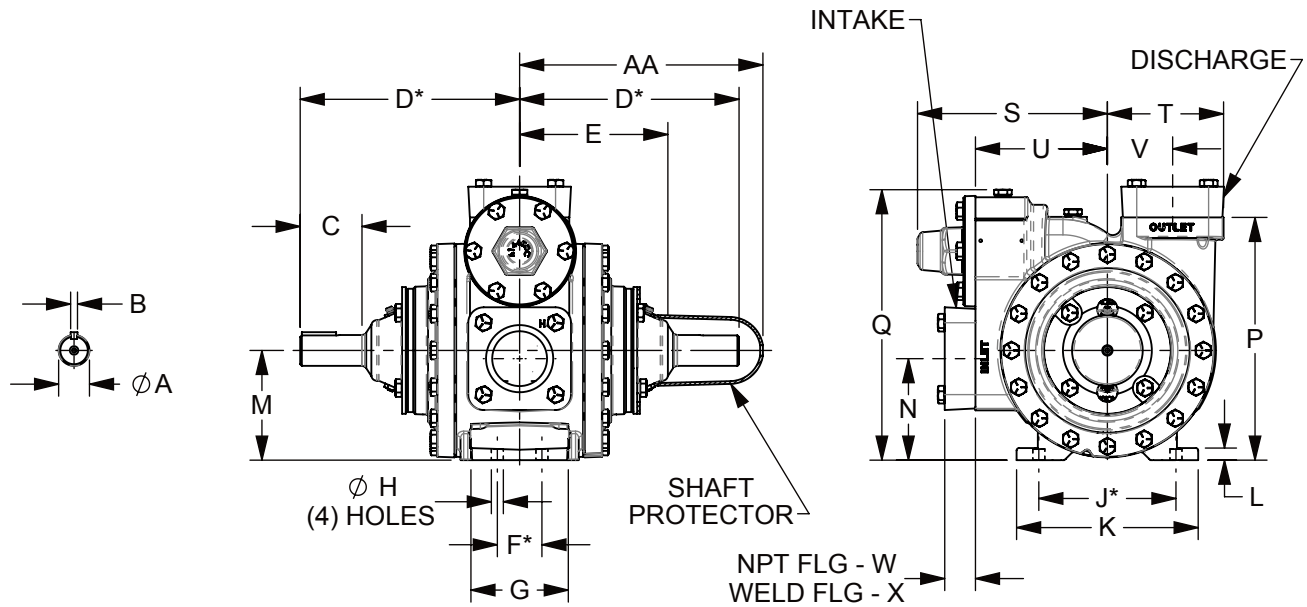

DIMENSIONS											WEIGHTS	
UNITS	A	B	C	D	E	F	G	H	J	K	UNITS	PUMP ONLY
IN	1 1/8	1/4	2 1/4	8	5 7/16	1 5/8	3 9/16	7/16	5	6 5/8	LBS	79
MM	28,6	6,4	57,2	203,2	138,1	41,3	90,5	11,1	127	168,3	KG	36
	L	M	N	P	Q	R	S	T	U	V		WITH NPT FLANGES
IN	7/16	4	3 3/4	8 7/8	9 7/8	---	6 7/8	4 3/16	4 13/16	2 3/8	LBS	84
MM	11,1	101,6	95,3	225,4	250,8	---	174,6	106,4	122,2	60,3	KG	38
	W	X	Y	Z	AA	BB	CC	DD	EE	FF		WITH WELD FLANGES
IN	1 1/8	1 3/16	1 1/4	5/16	8 15/16	---	---	10 3/4	---	---	LBS	84
MM	28,6	30,2	31,8	7,9	227	---	---	273	---	---	KG	38
	GG	HH	JJ	KK	LL	MM						HYD DRIVE NO FLANGES
IN	---	---	---	---	---	---					LBS	85
MM	---	---	---	---	---	---					KG	39



TYPE	SIZE	UNIT STYLE
SGL	2	N15

DIMENSIONS 801-102	
Section Effective Replaces Page 3 / 5	801 SEPTEMBER 2023 JUNE 2018

RIGHT HAND ROTATION. FOR LEFT HAND ROTATION, SHAFT PROJECTION IS OPPOSITE THAT SHOWN.

SGL2 WITH N15 GEARBOX OPTION SHOWN.

*TOLERANCE $\pm 1/8"$

TOLERANCE ON OTHER DIMENSIONS $\pm 1/4"$

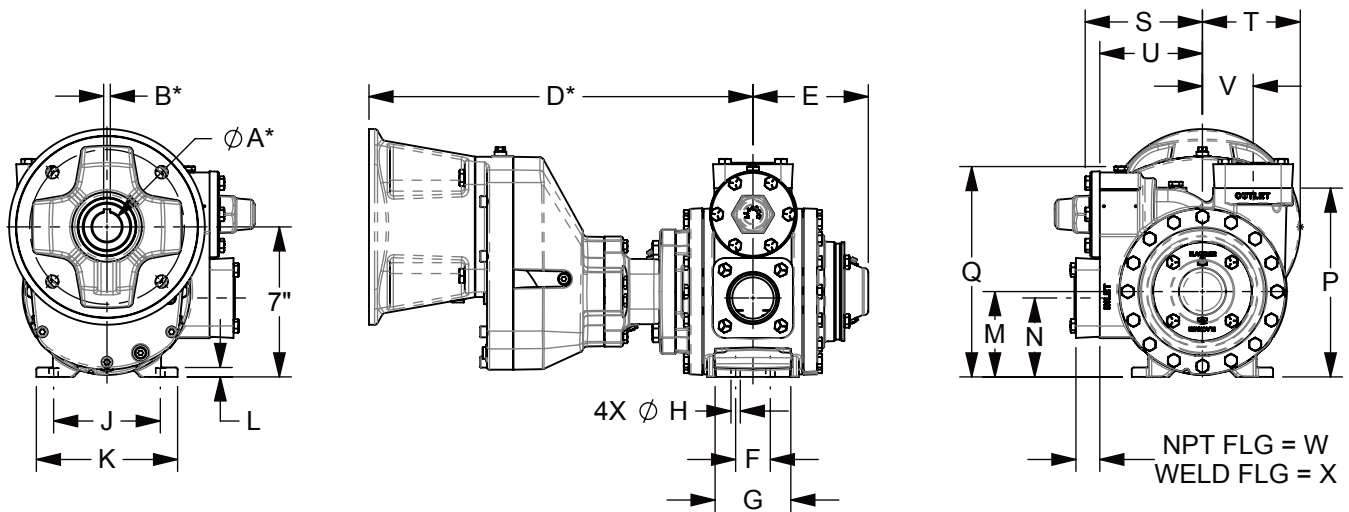

MOTOR SIZE	ϕA^*	B*	D*
NEMA 180TC	1 1/8	1/4	17 1/4
NEMA 210TC	1 3/8	5/16	18
IEC 100/112 B5	28mm	8mm	21 5/16

DIMENSIONS											WEIGHTS	
UNITS	A	B	C	D	E	F	G	H	J	K	UNITS	PUMP ONLY
IN	---	---	---	---	5 3/8	1 5/8	3 1/2	7/16	5	6 5/8	LBS	84
MM	---	---	---	---	136,5	41,3	88,9	11,1	127	168,3	KG	38
	L	M	N	P	Q	R	S	T	U	V		NPT FLANGES
IN	7/16	4	3 3/4	8 7/8	9 7/8	---	5 1/2	4 9/16	4 13/16	2 3/8	LBS	89
MM	11,1	101,6	85,7	225,4	250,8	---	139,7	115,9	122,2	60,3	KG	40
	W	X	Y	Z	AA	BB	CC	DD	EE	FF		WELD FLANGES
IN	1 1/8	1 3/16	---	---	---	---	---	---	---	---	LBS	89
MM	28,6	30,2	---	---	---	---	---	---	---	---	KG	40
	GG	HH	JJ	KK	LL	MM						ANSI FLANGES
IN	---	---	---	---	---	---					LBS	---
MM	---	---	---	---	---	---					KG	---

