

# HD and HDL Two-Stage Non-Lube Gas Compressors

- Air
- Allene
- Ammonia
- Argon
- Benzene
- Bromotrifluoromethane
- Butadiene
- Butane
- Carbon Dioxide
- Carbon Monoxide
- Carbon Tetrachloride
- Carbon Tetrafluoride
- CFC's
- Chlorine
- Chlorodifluoromethane
- Chloroform
- Chlorotrifluoroethylene
- Chlorotrifluoromethane
- Cyanogen
- Cyclohexane
- Cyclopropane
- Deuterium
- Dibromodifluoromethane
- Dichlorodifluoromethane
- Dichlorofluoromethane
- 1,2 Dichlorotetra-fluoroethane
- 1,1 Difluoro 1-Chloroethane
- Dimethylamine
- Dimethyl Ether

- 2,2 Dimethylpropane
- Ethane
- Ethyl Alcohol
- Ethyl Chloride
- Ethylene
- Ethylene Oxide
- HCFC's
- Helium
- n-Heptane
- n-Hexane
- Hydrogen

- Hydrogen Chloride
- Hydrogen Sulfide
- Isobutane
- Isobutene
- Isobutylene
- Isopentane
- Methane
- Methanol
- Methyl Acetylene
- Methyl Acetylene Propadiene
- Methyl Chloride
- Methyl Mercaptan
- Monoethylamine
- Natural Gas
- Neon
- Nitrogen
- Nitrogen Dioxide
- Nitrous Oxide
- Oxygen
- Ozone
- n-Octane
- n-Pentane
- Propane
- Propylene
- Refrigerants
- Sulfur Dioxide
- Sulfur Hexafluoride
- Trichloroethane
- Tetrafluoroethylene
- Trimethylamine
- Vinyl Chloride
- Xenon
- ....and others

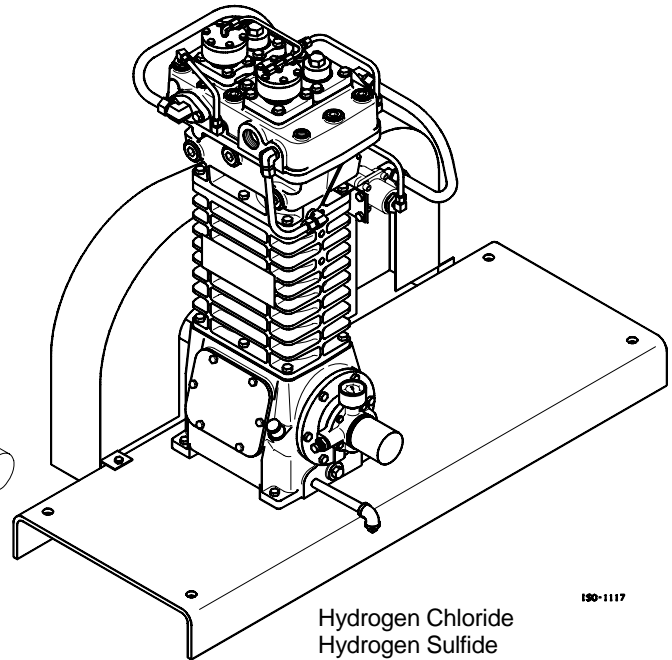
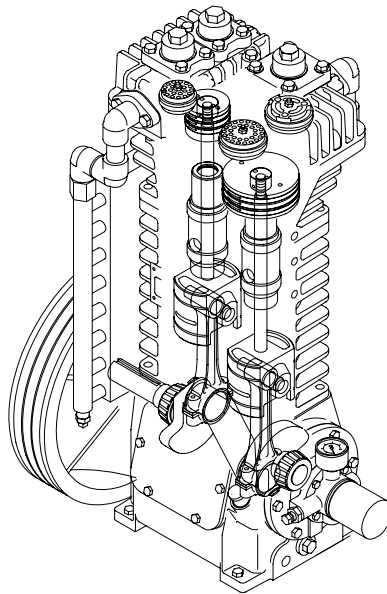

190-1117

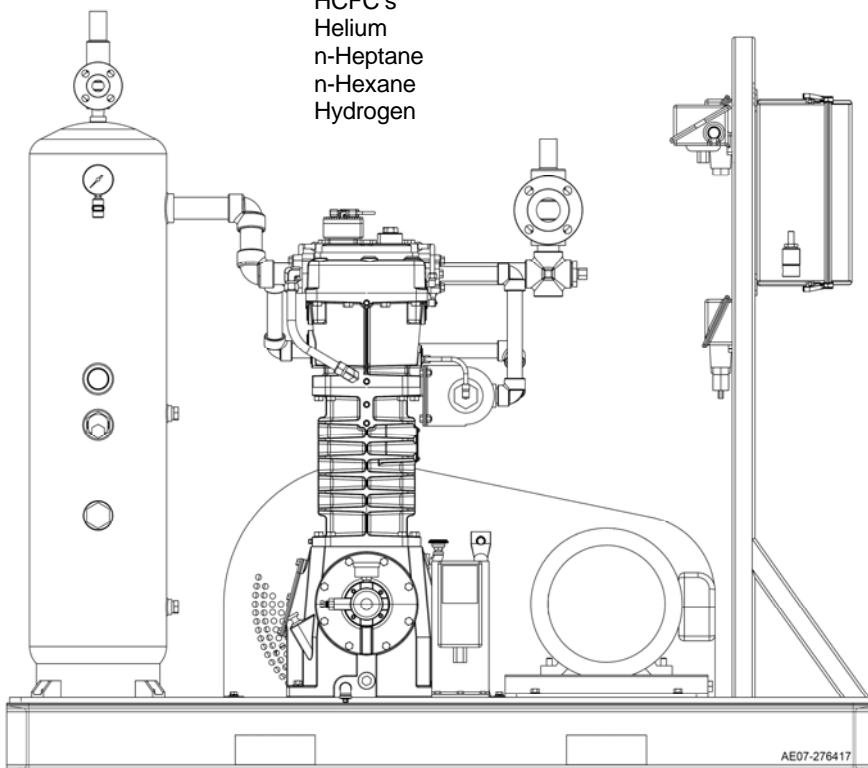

AE07-276417

## Typical Applications

- Vapor Recovery
- Gas Gathering
- Gas Transfer
- Gas Evacuation
- Enhanced Recovery
- Gas Blanketing
- Pressure Boosting
- Flare Elimination
- Leak Test Recovery
- Liquid Gas Transfer

## SPECIFICATIONS

Model	Double-Seal Triple-Seal	HD172 HDL172 HD173 HDL173	HD372 HDL372 HD373 HDL373	HD612 HDL612 HD613 HDL613
# Cyl. Per Stage		1	1	1
Bore - in. (mm)	Stage 1 Stage 2	3.0 (76.2) 1.75 (44.5)	4.625 (117) 2.687 (68)	6 (152) 3.25(.83)
Stroke - in. (mm)		2.5 (63.5)	3.0 (76)	4.0 (102)
MAWP - psia (bar)		615 (42.4)	615 (42.4)	415 (28.6)
Piston rod dia. - in. (mm)		0.75 (19.1)	0.75 (19.1)	1.25 (31.8)
Min. / Max. Speed (rpm)		350 / 825	350 / 825	350 / 825
Piston Displacement				
@ 100 rpm - CFM (m <sup>3</sup> /hr)		1.02 (1.73)	2.92 (4.96)	6.54 (11.1)
@ Min rpm - CFM (m <sup>3</sup> /hr)		3.57 (6.07)	10.2 (17.3)	22.9 (38.9)
@ Max rpm - CFM (m <sup>3</sup> /hr)		8.42 (14.3)	24.1 (40.8)	53.7 (91.2)
Max. Discharge Temperature *		350°F (176°C)	350°F (176°C)	350°F (176°C)
Max. BHP (kw)		10 (7.5)	15 (11)	40 (30)
Approx Wt. w/ Flywheel - lb. (kg)		245 (111)	405 (184)	775 (352)
Coolant Connections (HDL only)		1/4" NPT	1/4" NPT x 1/2" NPT	1/4" NPT x 1/2" NPT
Inlet – Stage 1		3/4" NPT, tapped	1.25" NPT, tapped	2" NPT Flange*
Outlet – Stage 1 Inlet – Stage 2		1/2" NPT, tapped	1" NPT Flange	1" NPT Flange
Outlet – Stage 2.		3/4" NPT, tapped	1" NPT, tapped	1.5" NPT Flange*

\* Weld Flanges available

'HD' models are air-cooled; 'HDL' models are liquid-cooled For sour gas applications; see CB-311 re 'HDS' Series.

\* Compression Ratios are normally limited by discharge temperature. High compression ratios and certain gases can cause excessive heat, i.e. over 350°F (176°C). The duty cycle must provide for adequate cooling time between periods of operation to prevent excessive operating temperature.



## TYPICAL MOUNTING STYLES

- CO Compressor with flywheel.
- B Compressor mounted on a baseplate with V-belt drive system with guard and motor slide base ready to accept but less motor.
- TU -B Unit plus a mechanical liquid trap, NPT piping and pressure gauges.
- TC -B Unit plus an ASME code liquid trap, high liquid level switch, NPT piping and pressure gauges.
- TW -B Unit plus an ANSI flanged trap, high liquid level switch, welded piping and pressure gauges.

## STANDARD FEATURES

Ductile Iron Head & Cylinder provide toughness & strength unmatched by cast iron.

Water-cooled head & cylinders on HDL models reduce operating temperatures and extend wear life.

High efficiency PEEK (Poly Ether Ether Ketone) valve plates provide extended life due to the low mass and self-lubricating qualities of the PEEK material. In addition, the slight 'give' of a plastic versus a metal plate allows it to survive more abuse and provide better sealing throughout the life of the valve. (300, 600 series)

High efficiency stainless steel valve plates with steel seats and bumpers are impregnated with TNT-12, a proprietary mixture of PTFE and Nickel. The result is a self-lubricating valve with excellent corrosion resistance and extremely long life. (100 Series)

Extra thick PTFE piston rings provide more wear surface to provide greater ring life.

O-ring head seals provide positive sealing under all operating conditions. No asbestos to worry about, and materials are available to suit any application.

Triple-Seal (double distance piece), Double-Seal (single distance piece) and Single-Seal (no distance piece) models allow precise leakage control and minimize product contamination.

The center head bolts do not pass through the gas chambers and thus do not require a head bolt gasket. No gasket, no leakage source!

One piece steel or ductile iron pistons are attached to the piston rod via one positive locking nut.

Steel wrist pins ride on steel needle bearings for extra life under severe conditions.

Self-adjusting PTFE piston rod seals provide maximum sealing & minimum friction.

Iron crossheads feature special machined lube channels for maximum lubrication and wear resistance.

Crankcase is pressure lubricated via a self reversing oil pump directly driven by the crankshaft. Oil is fed to all bearing surfaces, including the crosshead. An automotive type spin-on oil filter is standard.

No brass or copper is present in the compressor.



## OPTIONS

TNT-12 corrosion & wear resistant treatment  
Various O-ring materials  
Oversized flywheels

Alternate piston ring materials  
Suction valve unloaders

Aluminum or stainless steel belt guards  
Pressure switches  
Temperature switches  
Temperature gauges  
Thermowells  
Vibration switches  
Level switches  
Control panels and starters  
Liquid traps  
NPT or welded piping systems

Epoxy paint systems  
Pressure gauges  
Receivers  
Capacity control bypass systems  
Relief valves  
Shutoff Valves - manual or powered  
Inlet strainers  
Aftercoolers - air or water-cooled  
Motor or engine drives  
Repair tool kits

## MATERIALS OF CONSTRUCTION

Cylinder & Head	Ductile Iron (A536 65-45-12 Nodular)
Pistons	Steel
Piston Rings	Glass & Moly Filled PTFE (Other materials available)
Piston Rods	BSR Steel (Chrome Oxide Coated avail.)
Valve Seats & Stops	Steel with TNT-12 Impregnation; SS available (100 series) Ductile Iron: TNT-12 Impregnation (300, 600 series)
Valve Plates	Stainless Steel (100 series) PEEK (300, 600 series)
Valve Springs	Stainless Steel
Rod Packing	PTFE
Crankshaft	Ductile Iron (A536 80-60-03 Nodular)
Connecting Rods	Ductile Iron (A536 60-40-18 Nodular)
Wrist Pin	Steel
Bearing, Wrist Pin	Steel Needle Bearing
Bearings, Rod	Babbitt Lined Steel Backed
Bearings, Crank	Tapered Roller
O-rings	Buna-N (PTFE, FKM, Neoprene, Ethylene Propylene available)
Metal Gaskets	Iron
Other Gaskets	Fiber (non Asbestos)
Crosshead Guide	Ductile Iron (A536 65-45-12 Nodular)
Crankcase & Crosshead	Gray Iron



# DIMENSIONS

## HD Air-Cooled Two-Stage Models

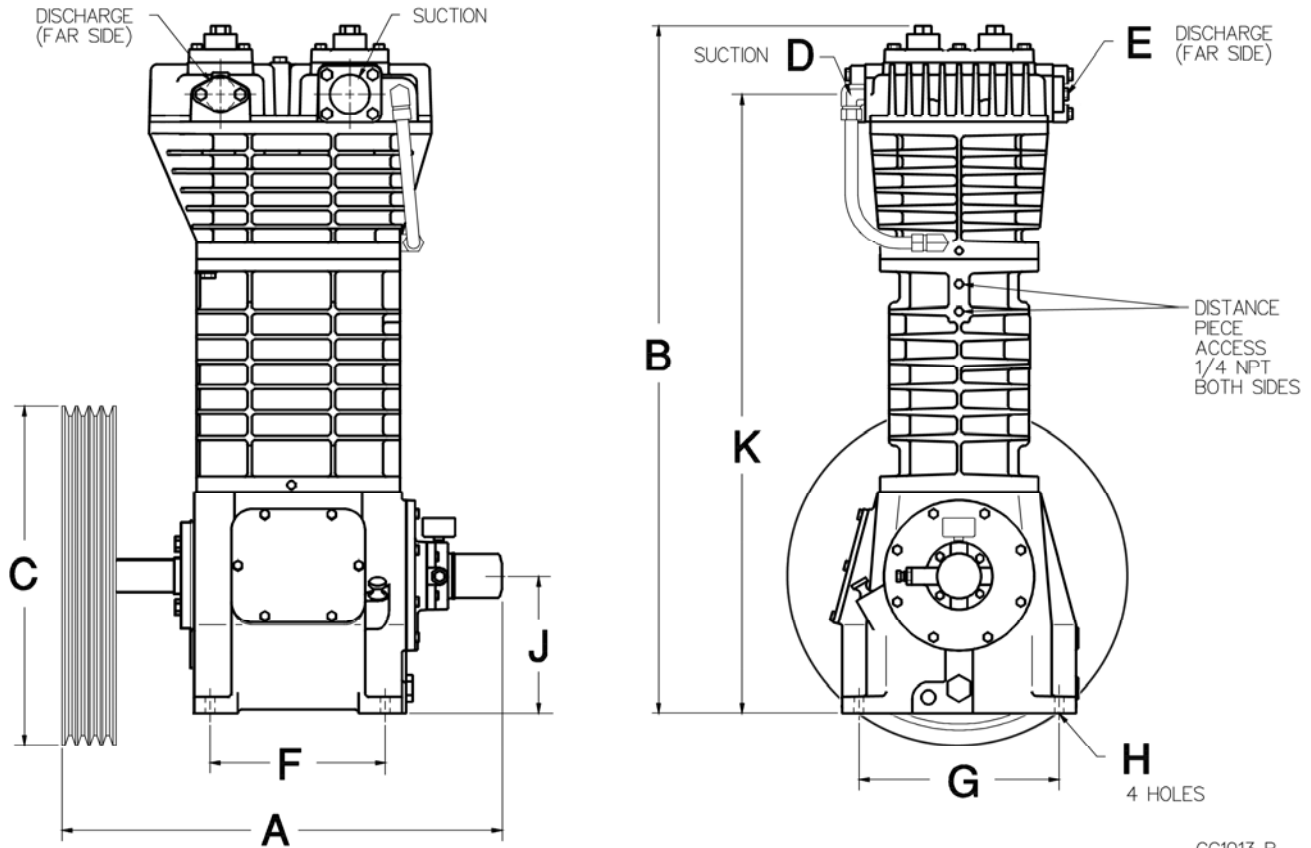

GC103 B

In. (mm)

Model	A	B	C	D	E	F	G	H	J	K
HD172	21.9 (556)	29.7* (755*)	16.35 (415)	3/4 NPT	3/4 NPT	7.5 (191)	7.38 (187)	0.44 (11)	5.37 (136)	27.37 (695)
HD173		33.89* (861*)								31.56 (802)
HD372	23.4 (594)	34.7* (880*)	16.35 (415)	1 1/4 NPT	1 NPT	9.12 (232)	9.37 (238)	0.5 (12.7)	5.88 (149)	30.79 (782)
HD373		39.3* (998*)								35.4 (900)
HD612	26.4 (671)	41.3* (1,049*)	20.35 (517)	2**	1.5**	10.5 (267)	12.0 (305)	0.56 (14.2)	8.25 (210)	37.22 (945)
HD613		47.42* (1,204*)								43.35 (1,101)

\* For units with Unloaders: 100 Series - add 2.7" (69 mm), 300 & 600 Series - add 1.6" (40 mm).

\*\* 600 Series: 2"NPT, 1.5"NPT, 2"WELD, & 1.5"WELD Available



# HDL Liquid-Cooled Two-Stage Models

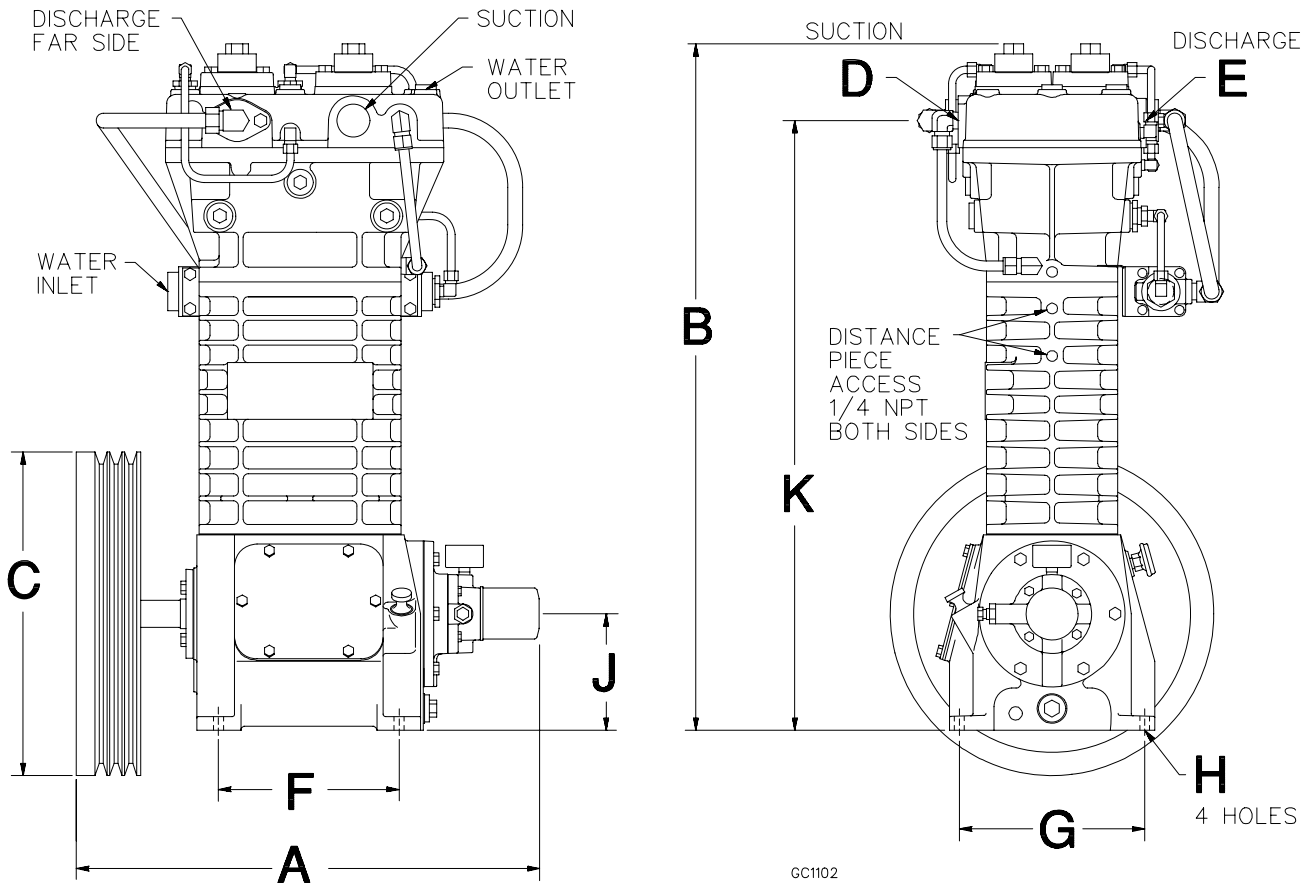

In. (mm)

Model	A	B	C	D	E	F	G	H	J	K
HDL172	21.9 (556)	29.7* (755*)	16.35 (415)	¾	¾	7.5 (191)	7.38 (187)	0.44 (11)	5.37 (136)	26.82 (681)
HDL173		33.89* (861*)		NPT	NPT					31.01 (788)
HDL372	23.4 (594)	34.7* (880*)	16.35 (415)	1.25	1	9.12 (232)	9.37 (238)	0.5 (12.7)	5.88 (149)	30.79 (782)
HDL373		39.3* (998*)		NPT	NPT					35.4 (900)
HDL612	26.4 (671)	41.3* (1,049*)	20.35 (517)	2**	1.5**	10.5 (267)	12.0 (305)	0.56 (14.2)	8.25 (210)	37.22 (945)
HDL613		47.42* (1,204*)								43.35 (1,101)

\* For units with Unloaders: 100 Series - add 2.7" (69 mm), 300 & 600 Series - add 1.6" (40 mm).

\*\* 600 Series: 2"NPT, 1.5"NPT, 2"WELD, & 1.5"WELD Available

