

CAD generated and maintained drawing. All printed and electronic copies outside of EnviroGear's engineering database are "Uncontrolled" and shall be used for reference only.

NOTES: UNLESS OTHERWISE SPECIFIED

1. DIMENSIONS AND TOLERANCES PER ASME Y14.5M-1994.
2. * INDICATES DIMENSIONS AND/OR FEATURES MODIFIED ON CURRENT REVISION LEVEL.
3. ALL DIMENSIONS ARE FOR REFERENCE ONLY.
4. DIMENSIONS IN [] ARE MILLIMETERS.
5. PORT ORIENTATION SHOWN MAY BE DIFFERENT THAN THE SELECTED ORIENTATION.
6. THIS DRAWING DOES NOT SHOW DETAILS OF ALL OPTIONS AND ACCESSORIES.
7. AVAILABLE WITH 1-1/2" NPT OR 1-1/2" BSPT PORTS.

REV.	DESCRIPTION	BY	CHK.	APP.	DATE
A	RELEASED INTO PRODUCTION SEE ECN #E00122	-	-	-	-
B	SEE ECN #E00195	C.L.	R.A.	J.F.	02/21/14
C	SEE ECN #E00281	C.L.	B.W.	B.S.	09/14/18

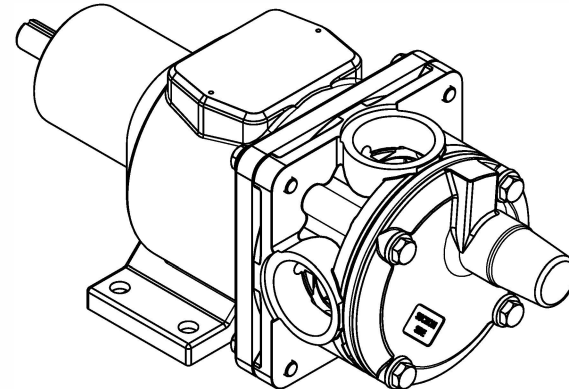
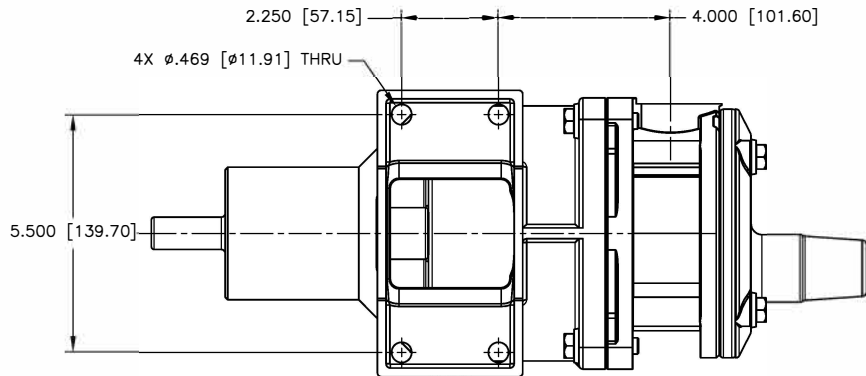
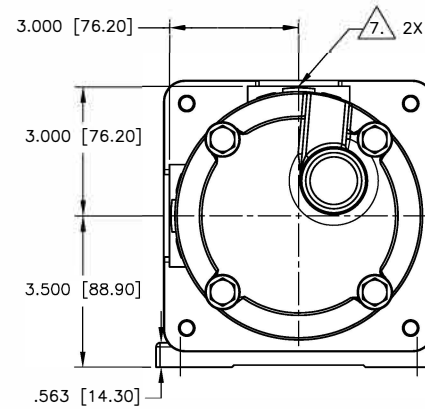
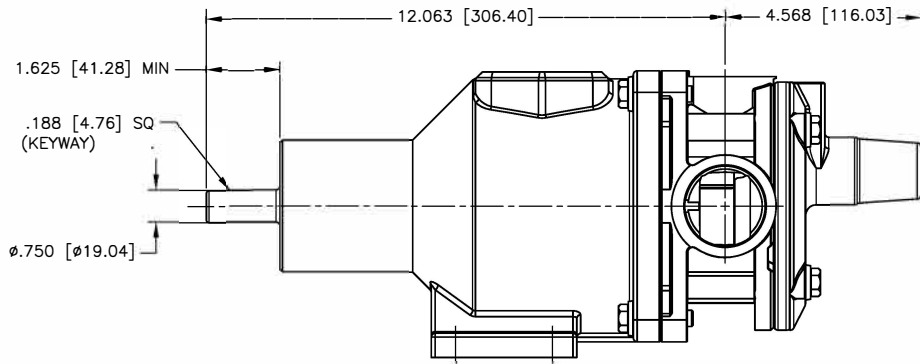

DO NOT SCALE DRAWING
UNLESS OTHERWISE SPECIFIED
DIMENSIONS ARE IN INCHES
TOLERANCES ARE:
DECIMALS .XX ± -
.XXX ± -
ANGLES ± -
SCALE 1/2 SHEET 1 OF 1

Blackmer		BLACKMER PUMPS 1809 CENTURY AVE SW GRAND RAPIDS, MI USA 49503 TELEPHONE: 616-241-1811 WWW.BLACKMER.COM	
TITLE E1-2/4, 1-1/2" NPT/BSPT, 90°, W/PRV DIMENSIONAL DRAWING			
DRAWN BY C. LEOPOLD	DATE 01/23/13	ASSY. NO.	
CHECKED BY R. ANDRADE	DATE 02/13/13	DRAWING NO.	
APPROVED BY N. WINSOR	DATE 02/13/13	LE0002	

THIS DOCUMENT AND ITS CONTENTS ARE PROPRIETARY TO
ENVIROGEAR INTERNAL GEAR PUMP. ANY REPRODUCTION,
DISCLOSURE OR USE OF THIS DOCUMENT IS EXPRESSLY
PROHIBITED EXCEPT AS OTHERWISE AGREED TO IN WRITING.