

NOTES: UNLESS OTHERWISE SPECIFIED

1. DIMENSIONS AND TOLERANCES PER ASME Y14.5M-1994.
2. \* INDICATES DIMENSIONS AND/OR FEATURES MODIFIED ON CURRENT REVISION LEVEL.
3. ALL DIMENSIONS ARE FOR REFERENCE ONLY.
4. DIMENSIONS IN [ ] ARE MILLIMETERS.
5. PORT ORIENTATION SHOWN MAY BE DIFFERENT THAN THE SELECTED ORIENTATION.
6. THIS DRAWING DOES NOT SHOW DETAILS OF ALL OPTIONS AND ACCESSORIES.
- \*  $\nabla$  7. AVAILABLE WITH ANSI 150# AND PN16 RAISED FACE. SEE FLANGE CHART FOR DIMENSIONS.

FLANGE DIMENSIONS				
1-1/2" ANSI 150#				
NOMINAL PIPE SIZE	FLANGE DIAMETER	BOLT CIRCLE DIA	NO OF BOLTS	BOLT HOLE SIZE
1.50 [38]	5.00 [127]	3.875 [98.42]	4	0.500-13 UNC - 2B
DIN40 ISO (DIN) PN16				
1.50 [38]	5.90 [150]	4.331 [110]	4	M16 X 2-6H

REV.	DESCRIPTION	BY	CHK.	APP.	DATE
A	RELEASED INTO PRODUCTION SEE ECN #E00122	-	-	-	-
B	SEE ECN #E00151	R.A.	M.H.	J.F.	5/6/13
C	SEE ECN #E00281	C.L.	B.W.	B.S.	09/14/18

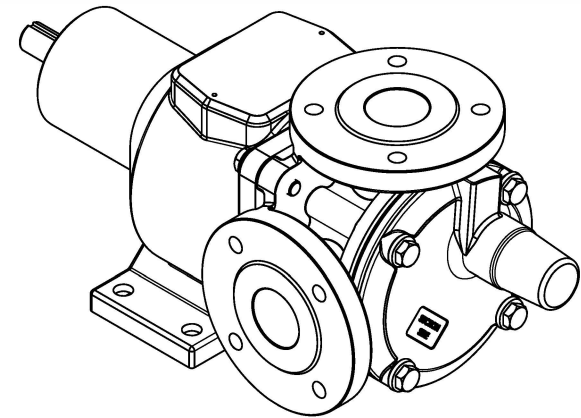
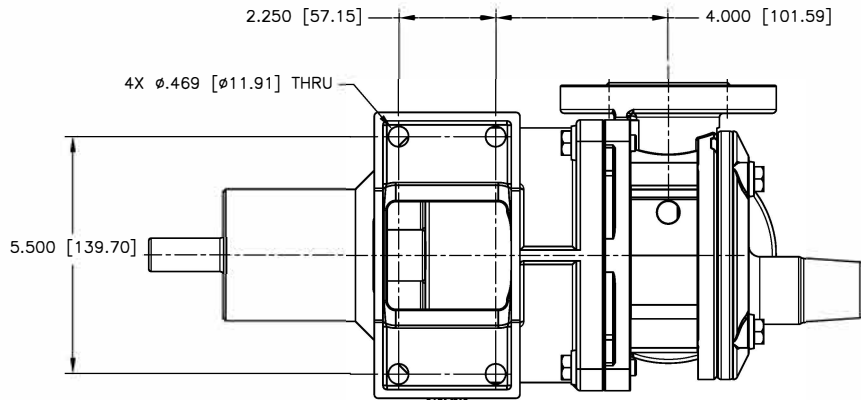
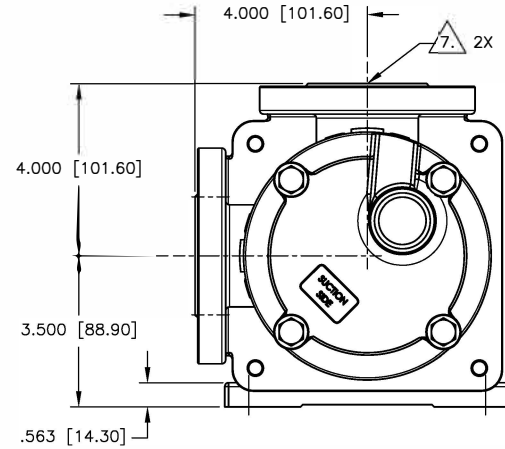
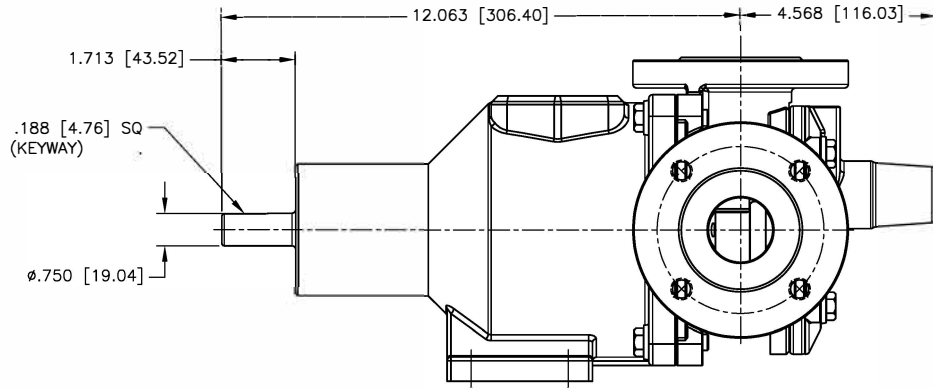

THIS DOCUMENT AND ITS CONTENTS ARE PROPRIETARY TO ENVIROGEAR INTERNAL GEAR PUMP. ANY REPRODUCTION, DISCLOSURE OR USE OF THIS DOCUMENT IS EXPRESSLY PROHIBITED EXCEPT AS OTHERWISE AGREED TO IN WRITING.

DO NOT SCALE DRAWING UNLESS OTHERWISE SPECIFIED DIMENSIONS ARE IN INCHES TOLERANCES ARE:		BLACKMER PUMPS 1809 CENTURY AVE SW GRAND RAPIDS, MI USA 49503 TELEPHONE: 616-241-1811 WWW.BLACKMER.COM	
DECIMALS .XX ± -	.XXX ± -	TITLE: E1-2/4, 1-1/2" ANSI, 90°, W/ PRV DIMENSIONAL DRAWING	
ANGLES ± -	SCALE 1/2	DRAWN BY: C. LEOPOLD CHECKED BY: R. ANDRADE APPROVED BY: N. WINSOR	DATE: 02/11/13 DATE: 02/13/13 DATE: 02/13/13
SHEET 1 OF 1		ASSY. NO: 02/13/13 DRAWING NO: LE0004	REV. C