

NOTES: UNLESS OTHERWISE SPECIFIED

1. DIMENSIONS AND TOLERANCES PER ASME Y14.5M-1994.
2. * INDICATES DIMENSIONS AND/OR FEATURES MODIFIED ON CURRENT REVISION LEVEL.
3. ALL DIMENSIONS ARE FOR REFERENCE ONLY.
4. DIMENSIONS IN [] ARE MILLIMETERS.
5. PORT ORIENTATION SHOWN MAY BE DIFFERENT THAN THE SELECTED ORIENTATION.
6. THIS DRAWING DOES NOT SHOW DETAILS OF ALL OPTIONS AND ACCESSORIES.
- * 7. AVAILABLE WITH ANSI 150# AND PN16 RAISED FACE. SEE FLANGE CHART FOR DIMENSIONS.

FLANGE DIMENSIONS				
1-1/2" ANSI 150#				
NOMINAL PIPE SIZE	FLANGE DIAMETER	BOLT CIRCLE DIA	NO OF BOLTS	BOLT HOLE SIZE
1.50 [38]	5.00 [127]	3.875 [98.42]	4	0.500-13 UNC - 2B
DIN40 ISO (DIN) PN16				
1.50 [38]	5.90 [150]	4.331 [110]	4	M16 X 2-6H

REV.	DESCRIPTION	BY	CHK.	APP.	DATE
A	RELEASED INTO PRODUCTION SEE ECN #E00122	-	-	-	-
B	SEE ECN #E00195	C.L.	R.A.	J.F.	02/21/14
C	SEE ECN #E00281	C.L.	B.W.	B.S.	09/14/14

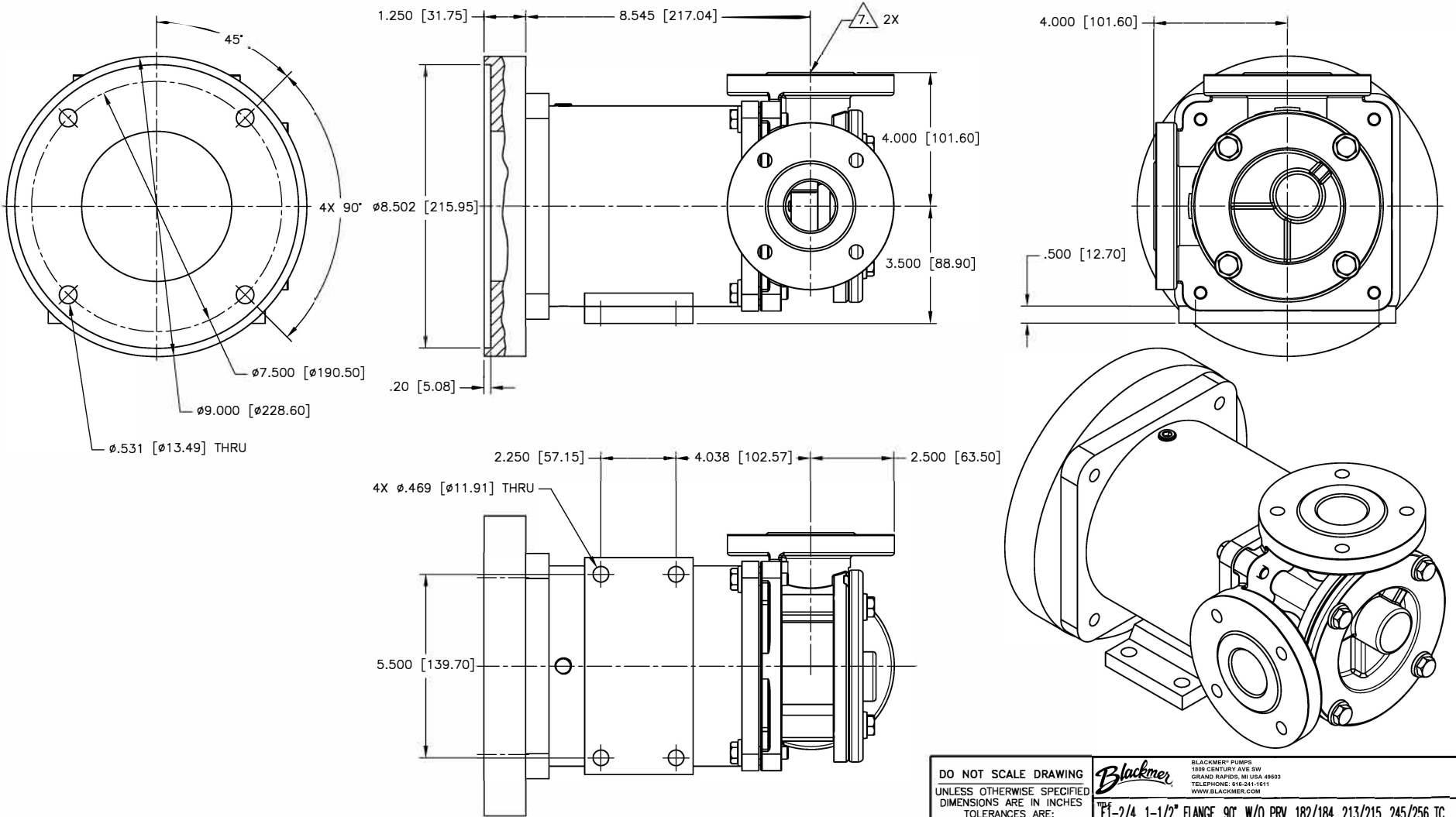

DO NOT SCALE DRAWING		Blackmer		BLACKMER PUMPS 1809 CENTURY AVE SW GRAND RAPIDS, MI USA 49503 TELEPHONE 616-241-1611 WWW.BLACKMER.COM	
UNLESS OTHERWISE SPECIFIED DIMENSIONS ARE IN INCHES TOLERANCES ARE:		TYPE E1-2/4, 1-1/2" FLANGE, 90°, W/O PRV, 182/184, 213/215, 245/256 TC DIMENSIONAL DRAWING			
DECIMALS .XX ± -		DRAWN BY C. LEOPOLD	DATE 01/24/13	ASSY. NO.	
.XXX ± -		CHECKED R. ANDRADE	DATE 02/13/13	DRAWING NO.	
ANGLES ± -		APPROVED N. WINSOR	DATE 02/13/13	REV.	
SCALE 1/2	SHEET 1 OF 1			LE0006	C

THIS DOCUMENT AND ITS CONTENTS ARE PROPRIETARY TO ENVIROGEAR INTERNAL GEAR PUMP. ANY REPRODUCTION, DISCLOSURE OR USE OF THIS DOCUMENT IS EXPRESSLY PROHIBITED EXCEPT AS OTHERWISE AGREED TO IN WRITING.