

NOTES: UNLESS OTHERWISE SPECIFIED

1. DIMENSIONS AND TOLERANCES PER ASME Y14.5M-1994.
2. * INDICATES DIMENSIONS AND/OR FEATURES MODIFIED ON CURRENT REVISION LEVEL.
3. ALL DIMENSIONS ARE FOR REFERENCE ONLY.
4. DIMENSIONS IN [] ARE MILLIMETERS.
5. PORT ORIENTATION SHOWN MAY BE DIFFERENT THAN THE SELECTED ORIENTATION.
6. THIS DRAWING DOES NOT SHOW DETAILS OF ALL OPTIONS AND ACCESSORIES.
7. ANSI 150# COMPATIBLE FLANGES. SEE FLANGE CHART FOR DIMENSIONS.

FLANGE DIMENSIONS			
2" ANSI 150# COMPATIBLE			
NOMINAL PIPE SIZE	BOLT CIRCLE DIA	NO OF BOLTS	BOLT HOLE SIZE
2.00 [50.8]	4.75 [120.7]	4	0.625-11 UNC-2B

REV.	DESCRIPTION	BY	CHK.	APP.	DATE
A	RELEASED INTO PRODUCTION SEE ECN #E00122	-	-	-	-
B	SEE ECN #E00195	C.L.	R.A.	J.F.	02/21/14
C	SEE ECN #E00284	HARI	C.L.	B.W.	10/18/14

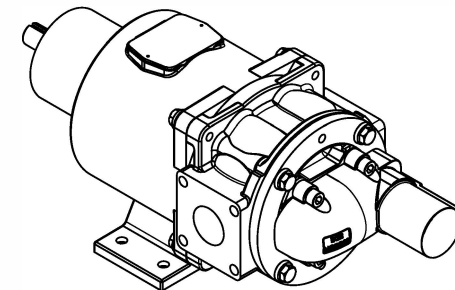
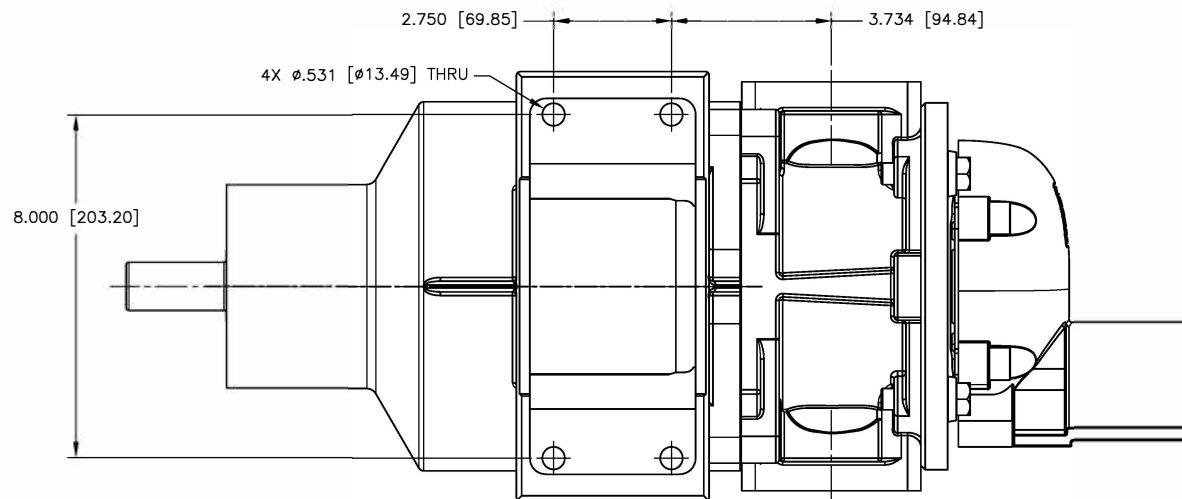
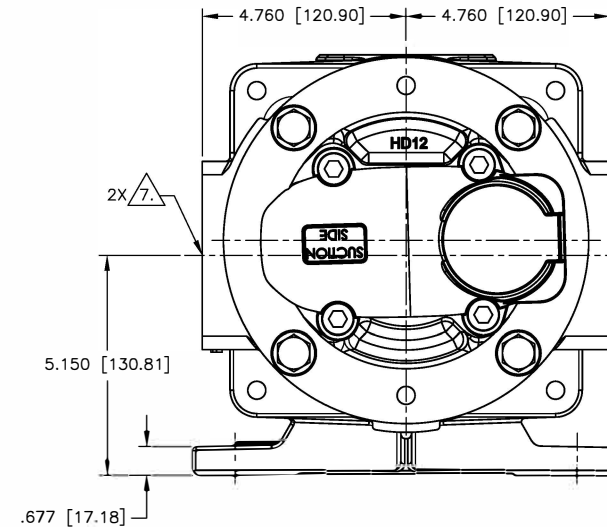
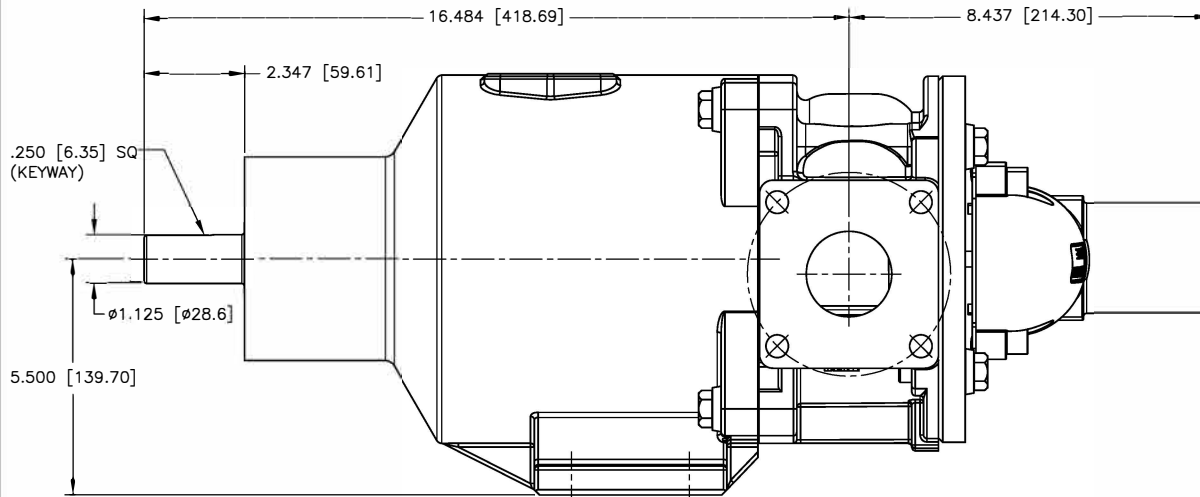

THIS DOCUMENT AND ITS CONTENTS ARE PROPRIETARY TO ENVIROGEAR INTERNAL GEAR PUMP. ANY REPRODUCTION, DISCLOSURE OR USE OF THIS DOCUMENT IS EXPRESSLY PROHIBITED EXCEPT AS OTHERWISE AGREED TO IN WRITING.

DO NOT SCALE DRAWING		BLACKMER PUMPS 1809 CENTURY AVE SW GRAND RAPIDS, MI USA 49503 TELEPHONE: 616-261-1511 WWW.BLACKMER.COM	
UNLESS OTHERWISE SPECIFIED DIMENSIONS ARE IN INCHES TOLERANCES ARE:		TITLE E1-24/32, 2" ANSI, 180 DEG, W/ PRV DIMENSIONAL DRAWING	
DECIMALS .XX ± -	DRAWN BY C. LEOPOLD	DATE 01/24/13	ASSY. NO.
.XXX ± -	CHECKED BY R. ANDRADE	DATE 02/13/13	DRAWING NO.
ANGLES ± -	APPROVED BY N. WINSOR	DATE 02/13/13	REV. C
SCALE 1/2	SHEET 1 OF 1	LE0012 REVISED 02-02-2014	