

NOTES: UNLESS OTHERWISE SPECIFIED

1. DIMENSIONS AND TOLERANCES PER ASME Y14.5M-1994.
2. * INDICATES DIMENSIONS AND/OR FEATURES MODIFIED ON CURRENT REVISION LEVEL.
3. ALL DIMENSIONS ARE FOR REFERENCE ONLY.
4. DIMENSIONS IN [] ARE MILLIMETERS.
5. PORT ORIENTATION SHOWN MAY BE DIFFERENT THAN THE SELECTED ORIENTATION.
6. THIS DRAWING DOES NOT SHOW DETAILS OF ALL OPTIONS AND ACCESSORIES.

*  AVAILABLE WITH 3" ANSI 150# RAISED FACED FLANGES, 4" ANSI 150# COMPATIBLE RAISED FACED FLANGES, AND PN16 COMPATIBLE RAISED FACE FLANGES. SEE FLANGE CHART FOR DIMENSIONS

FLANGE DIMENSIONS				
3" ANSI 150#				
NOMINAL PIPE SIZE	FLANGE DIAMETER	BOLT CIRCLE DIA	NO OF BOLTS	BOLT HOLE SIZE
3.00 [76.2]	7.50 [190]	6.00 [152.4]	4	0.625-11 UNC-2B
4" ANSI 150# COMPATIBLE				
4.00 [101.6]	9.00 [230]	7.50 [190.5]	8	0.625-11 UNC-2B
DIN80 ISO (DIN) PN16 COMPATIBLE				
3.00 [76.2]	7.90 [200]	6.299 [160]	4	M16 X 2-6H

REV.	DESCRIPTION	BY	CHK.	APP.	DATE
A	RELEASED INTO PRODUCTION SEE ECN #E00122	-	-	-	-
B	SEE ECN #E00195	C.L.	R.A.	J.F.	02/21/14
C	SEE ECN #E00284	HARI	C.L.	B.W.	10/18/16

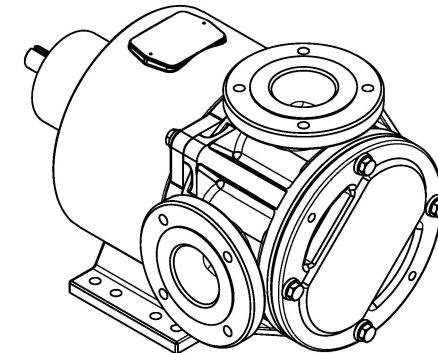
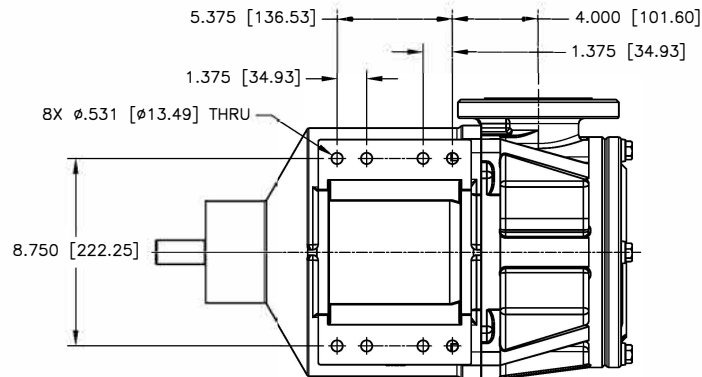
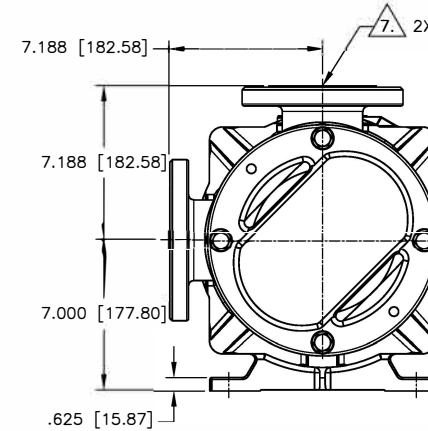
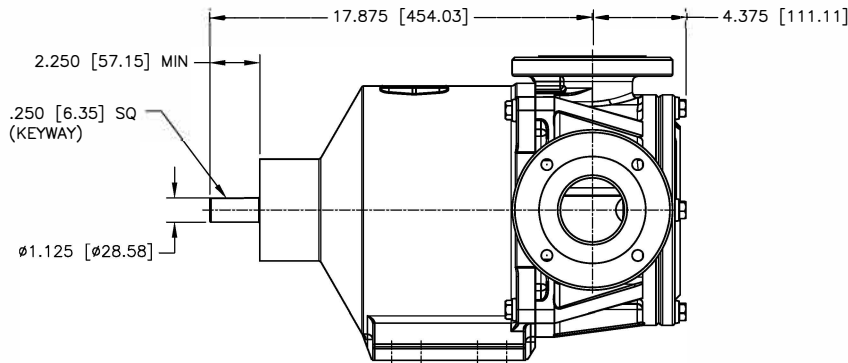

DO NOT SCALE DRAWING UNLESS OTHERWISE SPECIFIED DIMENSIONS ARE IN INCHES TOLERANCES ARE:		 BLACKMER PUMPS 1809 CENTURY AVE SW GRAND RAPIDS, MI USA 49503 TELEPHONE: 616-241-1811 WWW.BLACKMER.COM	
DECIMALS .XX ± -	.XXX ± -	TITLE: ET-55/69/82, FLANGE, 90 DEG, W/O PRV, SM SHAFT DIMENSIONAL DRAWING	
ANGLES ± -	SCALE 1/4	DRAWN BY C. LEOPOLD	DATE 01/24/13
	SHEET 1 OF 1	CHECKED BY R. ANDRADE	DATE 02/13/13
		APPROVED BY N. WINSOR	DATE 02/13/13
		REV. C	LE0017

THIS DOCUMENT AND ITS CONTENTS ARE PROPRIETARY TO ENVIROGEAR INTERNAL GEAR PUMP. ANY REPRODUCTION, DISCLOSURE OR USE OF THIS DOCUMENT IS EXPRESSLY PROHIBITED EXCEPT AS OTHERWISE AGREED TO IN WRITING.