

NOTES: UNLESS OTHERWISE SPECIFIED

1. DIMENSIONS AND TOLERANCES PER ASME Y14.5M-1994.
2. * INDICATES DIMENSIONS AND/OR FEATURES MODIFIED ON CURRENT REVISION LEVEL.
3. ALL DIMENSIONS ARE FOR REFERENCE ONLY.
4. DIMENSIONS IN [] ARE MILLIMETERS.
5. PORT ORIENTATION SHOWN MAY BE DIFFERENT THAN THE SELECTED ORIENTATION.
6. THIS DRAWING DOES NOT SHOW DETAILS OF ALL OPTIONS AND ACCESSORIES.
- * 7. AVAILABLE WITH 3" ANSI 150# RAISED FACED FLANGES, 4" ANSI 150# COMPATIBLE RAISED FACED FLANGES, AND PN16 COMPATIBLE RAISED FACE FLANGES. SEE FLANGE CHART FOR DIMENSIONS

FLANGE DIMENSIONS				
3" ANSI 150#				
NOMINAL PIPE SIZE	FLANGE DIAMETER	BOLT CIRCLE DIA	NO OF BOLTS	BOLT HOLE SIZE
3.00 [76.2]	7.50 [190]	6.00 [152.4]	4	0.625-11 UNC-2B
4" ANSI 150# COMPATIBLE				
4.00 [101.6]	9.00 [230]	7.50 [190.5]	8	0.625-11 UNC-2B
DIN80 ISO (DIN) PN16 COMPATIBLE				
3.00 [76.2]	7.90 [200]	6.299 [160]	4	M16 X 2-6H

REV.	DESCRIPTION	BY	CHK.	APP.	DATE
A	RELEASED INTO PRODUCTION SEE ECN #E00122	-	-	-	-
B	SEE ECN #E00195	C.L.	R.A.	J.F.	02/21/13
C	SEE ECN #E00276	C.L.	L.L.	B.S.	06/02/13
D	SEE ECN #E00284	HARI	C.L.	B.W.	10/18/13

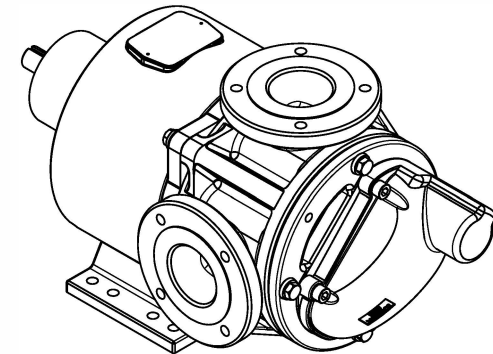
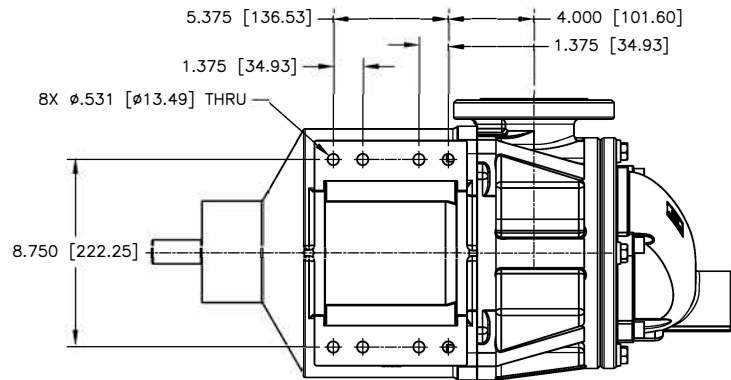
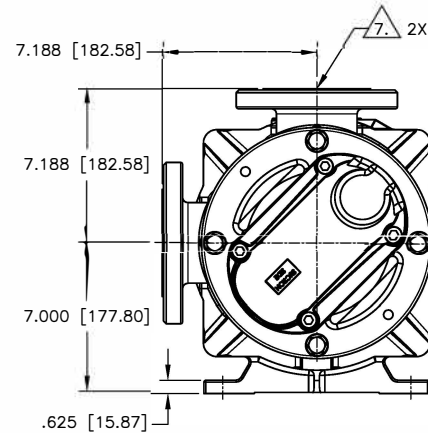
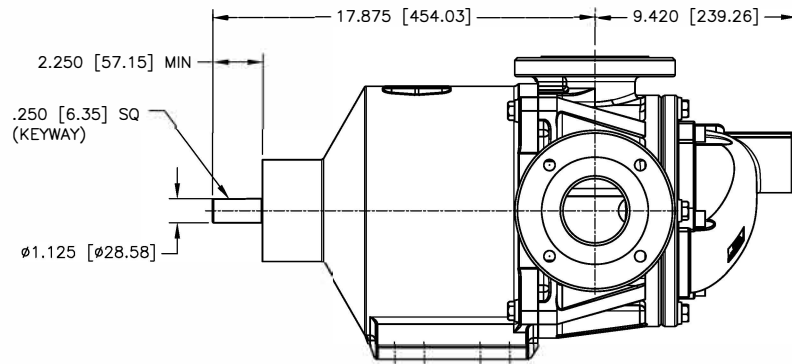

DO NOT SCALE DRAWING UNLESS OTHERWISE SPECIFIED DIMENSIONS ARE IN INCHES TOLERANCES ARE:		BLACKMER® PUMPS 1809 CENTURY AVE SW GRAND RAPIDS, MI USA 49503 TELEPHONE: 616-241-1811 WWW.BLACKMER.COM	
DECIMALS .XX ± -		TITLE E1-55/69/82, FLANGE, 90 DEG, PRV, SM SHAFT DIMENSIONAL DRAWING	
.XXX ± -		DRAWN BY C. LEOPOLD	DATE 01/24/13
ANGLES ± -		CHECKED BY R. ANDRADE	DATE 02/13/13
SCALE -	SHEET 1 OF 1	APPROVED BY N. WINSOR	DATE 02/13/13
			REV. D

THIS DOCUMENT AND ITS CONTENTS ARE PROPRIETARY TO ENVIROGEAR INTERNAL GEAR PUMP. ANY REPRODUCTION, DISCLOSURE OR USE OF THIS DOCUMENT IS EXPRESSLY PROHIBITED EXCEPT AS OTHERWISE AGREED TO IN WRITING.