

CAD generated and maintained drawing. All printed and electronic copies outside of EnviroGear's engineering database are "Uncontrolled" and shall be used for reference only.

NOTES: UNLESS OTHERWISE SPECIFIED

1. DIMENSIONS AND TOLERANCES PER ASME Y14.5M-1994.
2. * INDICATES DIMENSIONS AND/OR FEATURES MODIFIED ON CURRENT REVISION LEVEL.
3. ALL DIMENSIONS ARE FOR REFERENCE ONLY.
4. DIMENSIONS IN [] ARE MILLIMETERS.
5. PORT ORIENTATION SHOWN MAY BE DIFFERENT THAN THE SELECTED ORIENTATION.
6. THIS DRAWING DOES NOT SHOW DETAILS OF ALL OPTIONS AND ACCESSORIES.
- *7. AVAILABLE WITH ANSI 150# AND PN16 RAISED FACE. SEE FLANGE CHART FOR DIMENSIONS.

FLANGE DIMENSIONS				
1-1/2" ANSI 150#				
NOMINAL PIPE SIZE	FLANGE DIAMETER	BOLT CIRCLE DIA	NO OF BOLTS	BOLT HOLE SIZE
1.50 [38]	5.00 [127]	3.875 [98.42]	4	0.500-13 UNC - 2B
DIN40 ISO (DIN) PN16				
1.50 [38]	5.90 [150]	4.331 [110]	4	M16 X 2-6H

REV.	DESCRIPTION	BY	CHK.	APP.	DATE
A	RELEASED INTO PRODUCTION SEE ECN #E00140	-	-	-	-
B	SEE ECN #E00195	C.L.	R.A.	J.F.	02/21/14
C	SEE ECN #E00281	C.L.	B.W.	B.S.	09/14/18

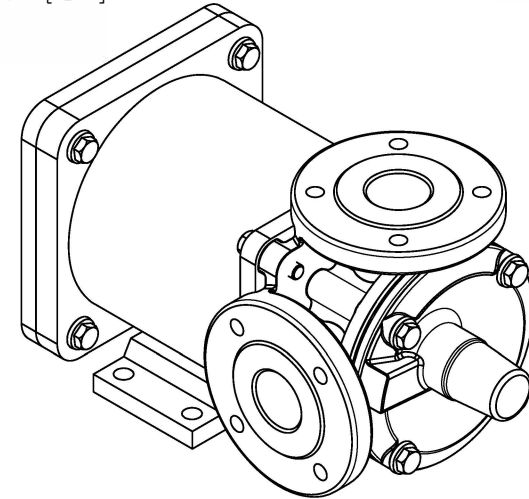
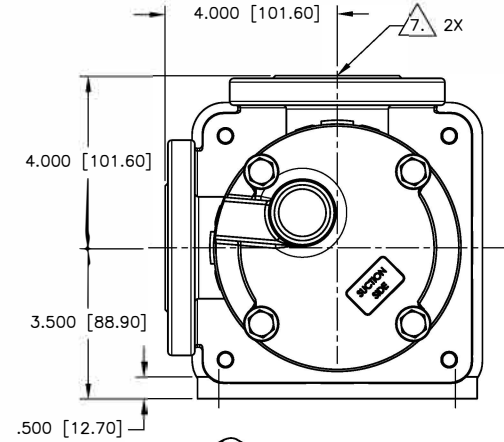
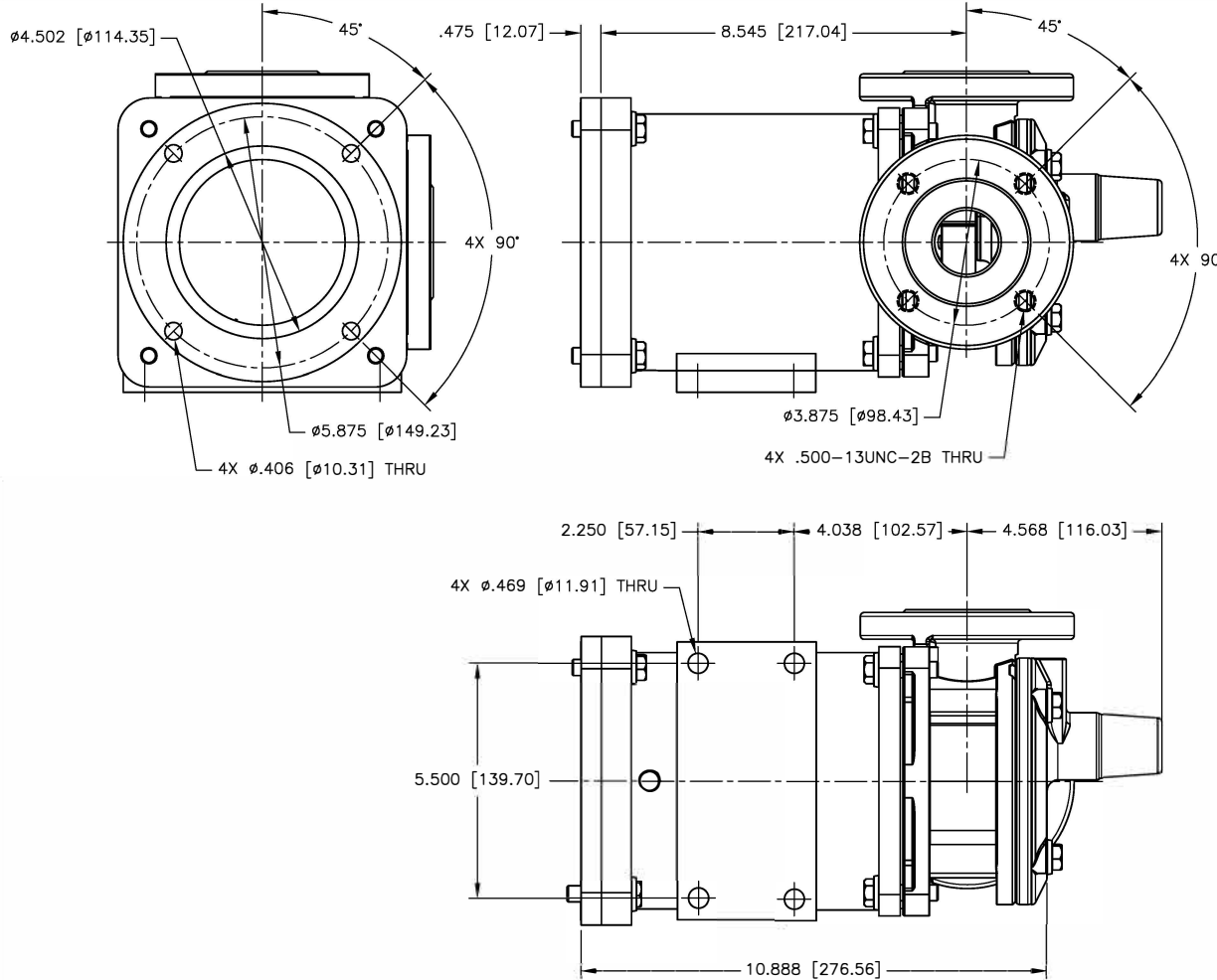

DO NOT SCALE DRAWING
UNLESS OTHERWISE SPECIFIED
DIMENSIONS ARE IN INCHES
TOLERANCES ARE:

DECIMALS .XX ± -
.XXX ± -
ANGLES ± -
SCALE 1/2 SHEET 1 OF 1

Blackmer BLACKMER PUMPS
1809 CENTURY AVE SW
GRAND RAPIDS, MI USA 49503
TELEPHONE: 616-241-1511
WWW.BLACKMER.COM

TITLE: E1-2/4, 1-1/2" FLANGE, 90°, W/ PRV, 143/145TC
DIMENSIONAL DRAWING

DRAWN BY: R. ANDRADE DATE: 03/20/13 ASSY. NO.:
CHECKED BY: C. LEOPOLD DATE: 03/20/13
APPROVED BY: J. FARLEY DATE: 03/20/13

DRAWING NO.: LE0021

THIS DOCUMENT AND ITS CONTENTS ARE PROPRIETARY TO
ENVIROGEAR INTERNAL GEAR PUMP. ANY REPRODUCTION,
DISCLOSURE OR USE OF THIS DOCUMENT IS EXPRESSLY
PROHIBITED EXCEPT AS OTHERWISE AGREED TO IN WRITING.