

REV	DESCRIPTION
A	RELEASED INTO PRODUCTION SEE ECN #GRT00022

NOTES: UNLESS OTHERWISE SPECIFIED

1. DIMENSIONS AND TOLERANCES PER ASME Y14.5M-1994.
2. * INDICATES DIMENSIONS AND/OR FEATURES MODIFIED ON CURRENT REV LEVEL.

3. MINIMUM DIMENSION FOR REPACKING.

THIS DRAWING DOES NOT SHOW DETAILS OF ALL OPTIONS AND ACCESSORIES

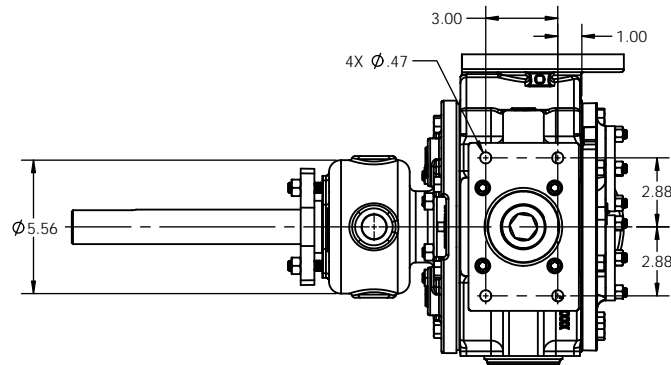
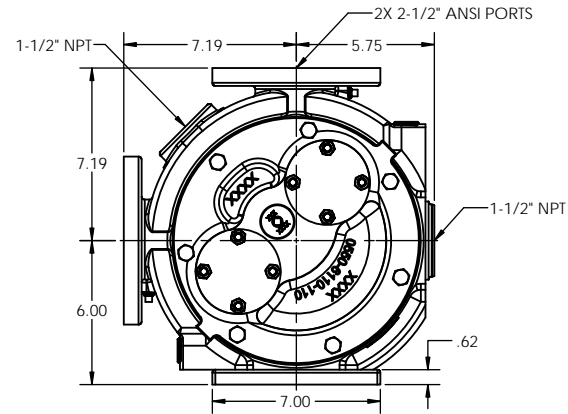
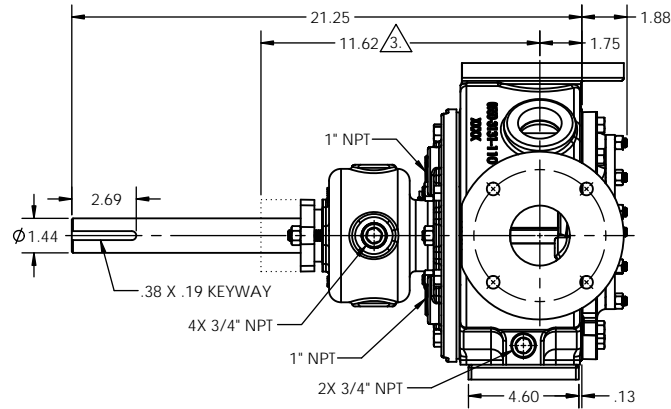

THIS DOCUMENT CONTAINS PROPRIETARY INFORMATION OF PSG - A DOVER COMPANY. ITS RECEIPT AND POSSESSION DO NOT CONVEY ANY RIGHTS TO REPRODUCE OR DISCLOSE ITS CONTENTS OR TO MANUFACTURE USE OR SELL ANYTHING IT MAY DESCRIBE. THIS DOCUMENT IS SUBJECT TO RETURN UPON REQUEST. REPRODUCTION, DISCLOSURE OR USE OF THIS DOCUMENT WITHOUT THE WRITTEN AUTHORIZATION OF DOVER CORPORATION IS STRICTLY FORBIDDEN.

DO NOT SCALE DRAWING
UNLESS OTHERWISE SPECIFIED
DIMENSIONS ARE IN INCHES
TOLERANCES ARE:

DECIMALS .XX ± -

ANGLES ± -

THIRD ANGLE PROJECTION

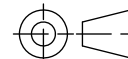

DRAWN BY CJK DATE 2017-12-19

APPROVED BY BKW DATE 2018-01-22



Blackmer

BLACKMER® PUMPS
1809 CENTURY AVE SW
GRAND RAPIDS, MI USA 49503
TELEPHONE: 616-241-1611
WWW.BLACKMER.COM

TITLE
PUMP ASSEMBLY, DIMENSIONAL
V2-55, NON-JACKETED HEAD, NO PRV

SIZE C DRAWING NO. **LM0060** REV. **A**

SCALE 1:4 SHEET 1 OF 1