

REV	DESCRIPTION
A	RELEASED INTO PRODUCTION SEE ECN #GRT001165

NOTES: UNLESS OTHERWISE SPECIFIED

1. DIMENSIONS AND TOLERANCES PER ASME Y14.5M-1994.
2. * INDICATES DIMENSIONS AND/OR FEATURES MODIFIED ON CURRENT REVISION LEVEL.

THIS DRAWING DOES NOT SHOW DETAILS OF ALL OPTIONS AND ACCESSORIES

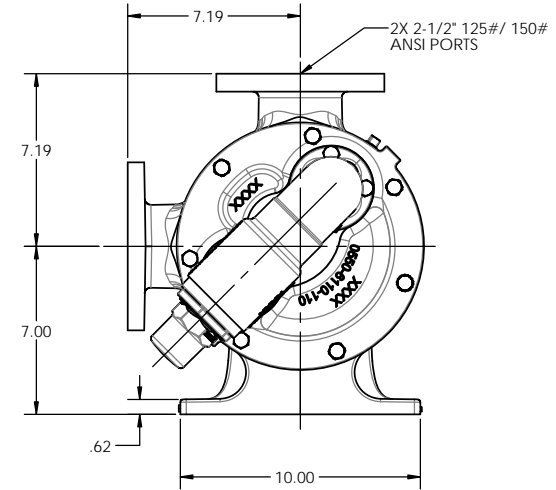
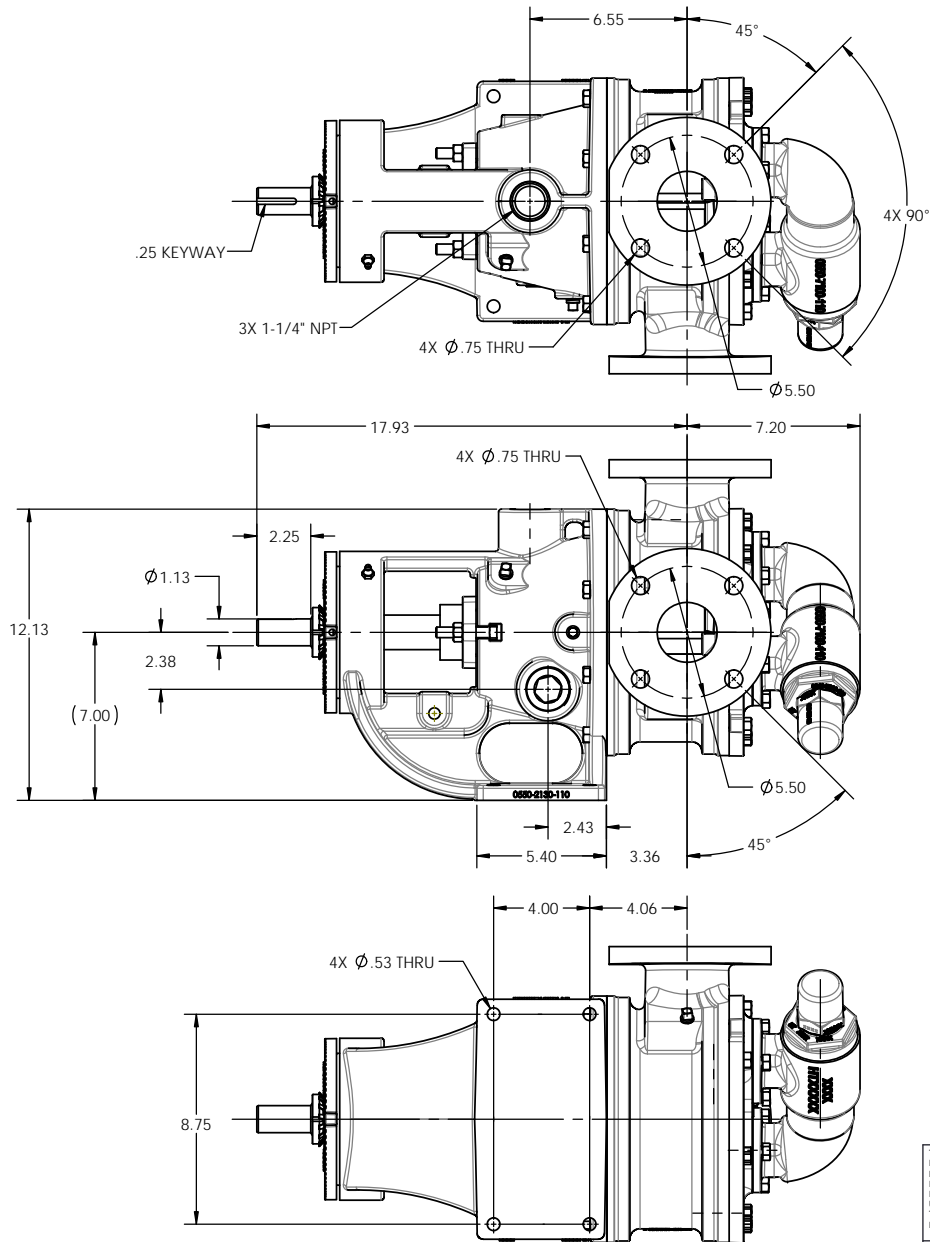

THIS DOCUMENT CONTAINS PROPRIETARY INFORMATION OF PSG - A DOVER COMPANY. ITS RECEIPT AND POSSESSION DO NOT CONVEY ANY RIGHTS TO REPRODUCE OR DISCLOSE ITS CONTENTS OR TO MANUFACTURE USE OR SELL ANYTHING IT MAY DESCRIBE. THIS DOCUMENT IS SUBJECT TO RETURN UPON REQUEST. REPRODUCTION, DISCLOSURE OR USE OF THIS DOCUMENT WITHOUT THE WRITTEN AUTHORIZATION OF DOVER CORPORATION IS STRICTLY FORBIDDEN.

DO NOT SCALE DRAWING
UNLESS OTHERWISE SPECIFIED
DIMENSIONS ARE IN INCHES
TOLERANCES ARE:

DECIMALS .XX ± -

ANGLES ± -

THIRD ANGLE PROJECTION

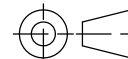

DRAWN BY RS	DATE 2019-01-25
APPROVED BY NJ	DATE 2020-10-22



Blackmer

BLACKMER® PUMPS
1600 CENTURY AVE SW
GRAND RAPIDS, MI USA 49503
TELEPHONE: 616-241-1611
WWW.BLACKMER.COM

TITLE	PUMP ASSEMBLY, DIMENSIONAL		
SIZE	C		
DRAWING NO.	LM0132	REV.	A
SCALE	1:4	SHEET	1 OF 1