

BLACKMER

INSTRUCTIONS, SIZES, MATERIALS AND PARTS LIST FOR ADJUSTABLE COUPLING GUARDS

| | |
|-----------|----------|
| Section | 115 |
| Effective | Aug 2008 |
| Replaces | Oct 2007 |



This is a SAFETY ALERT SYMBOL.

When you see this symbol on the product, or in the manual, look for one of the following signal words and be alert to the potential for personal injury, death or major property damage



Warns of hazards that **WILL** cause serious personal injury, death or major property damage.



Warns of hazards that **CAN** cause serious personal injury, death or major property damage.



Warns of hazards that **CAN** cause personal injury or property damage.

NOTICE:

Indicates special instructions which are very important and must be followed.

NOTICE:

Blackmer coupling guards **MUST** only be installed in systems which have been designed by qualified engineering personnel. The system **MUST** conform to all applicable local and national regulations and safety standards.

This manual is intended to assist in the installation and adjustment of the coupling guards, and **MUST** be kept with the pump.

Blackmer pump service shall be performed by qualified technicians **ONLY**. Service shall conform to all applicable local and national regulations and safety standards.

Thoroughly review this manual, all instructions and hazard warnings, **BEFORE** performing any work on the pump or system.

Maintain **ALL** system and Blackmer pump operation and hazard warning decals.

WARNING



Hazardous pressure can cause personal injury or property damage

Disconnecting fluid or pressure containment components during pump operation can cause serious personal injury, death or major property damage

WARNING



Hazardous voltage. Can shock, burn or cause death.

Failure to disconnect and lockout electrical power before attempting maintenance can cause shock, burns or death

WARNING



Hazardous machinery can cause serious personal injury.

Failure to disconnect and lockout electrical power or engine drive before attempting maintenance can cause severe personal injury or death

WARNING



Hazardous pressure can cause serious personal injury or property damage

Failure to relieve system pressure prior to performing pump service or maintenance can cause serious personal injury or property damage.

NOTICE:

The appropriate Blackmer pump manual and parts list may be obtained from the Blackmer website (www.blackmer.com) or by contacting Blackmer customer service.

NOTICE:

Maintenance and trouble shooting must be done by an individual experienced with pump maintenance and the type of system involved.

NOTICE:

The following instructions include only the steps necessary to install and adjust the Blackmer coupling guards. Before proceeding, read and follow all related instructions and hazard warnings provided in the appropriate pump "Installation, Operation and Maintenance" manual.

PRIOR TO COUPLING GUARD INSTALLATION

Be sure to have the appropriate size Coupling Guard for the application. Sizes and mounting dimensions are shown on Page 3 of this manual. Take measurements of the components you will be using to determine the following:

1. Diameter of coupling or rotating components covered by the guard **MUST NOT** exceed Diameter "A"
2. Centerline height of the pump's drive shaft/ coupling/ powerdrive **MUST** be between dimensions "B1" & "B2"
3. Distance between the pump drive shaft & the shaft of the powerdrive **MUST** be between dimensions "C1 and C2".

The guard extension sections **MUST** be abutted to within .25" (6,4 mm) maximum gap of the rotating equipment per standards.

(Ref. OSHA Std 1910.219, 1996, ASME B15.1, 2000, and ANSI Z535, 1998)

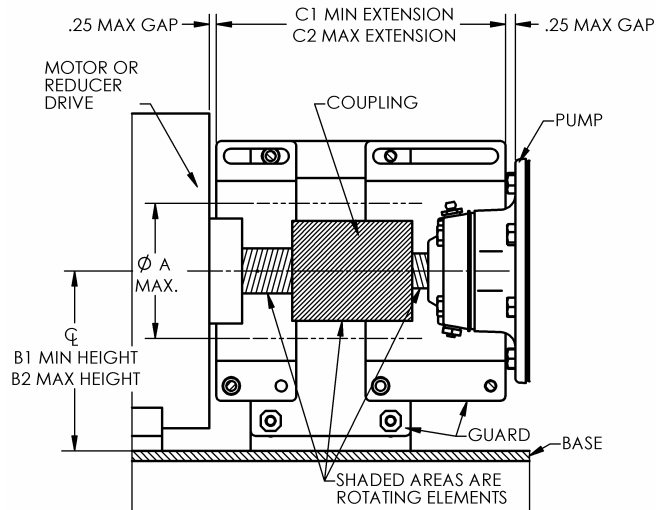

The Coupling Guard halves will be packed loosely assembled. Assemble the 2 halves and determine their position between the rotating elements.

Coupling Guard height can be adjusted by repositioning the (4) height adjustment bolts on each half section. Axial length can be adjusted by repositioning the Extension Adjustment Bolts.

COUPLING ALIGNMENT

The pump must be directly coupled to a gearbox and/or driver with a flexible coupling. Verify coupling alignment after installation of new or rebuilt pumps. Both angular and parallel coupling alignment **MUST** be maintained between the pump, gearbox, motor, etc. in accordance with manufacturer's instructions. See Figure 1.

1. Parallel alignment: The use of a laser alignment tool or dial indicator is preferred. If a laser alignment tool or dial indicator is not available, use a straightedge. Turn both shafts by hand; checking the reading through one complete revolution. Maximum offset should be less than .005" (.127 mm).

2. Angular alignment: Insert a feeler gauge between the coupling halves. Check the spacing at 90° increments around the coupling (four checkpoints). Maximum variation should not exceed .005" (.127 mm). Some laser alignment tools will check angular alignment as well.
3. Replace the coupling guards after setting alignment.

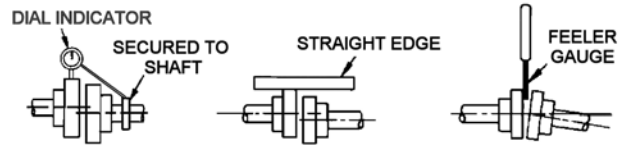

Figure 1 – Alignment Check

INSTALLATION

1. Position the coupling guard making the appropriate adjustments to either raise/lower the height of the guard to center it along the pump's drive shaft/ coupling/ powerdrive. Assure proper clearance with drive coupling. Reference dimension A
2. Position the extensions of the coupling guard making the appropriate adjustments to either shorten or lengthen the extensions of the guard, within .25" (6,4 mm) maximum gap of the rotating equipment per standards.

(Ref. OSHA Std 1910.219, 1996, ASME B15.1, 2000, and ANSI Z535, 1998)



Failure to adjust guards covering all rotating part, allowing only a safe gap, can cause personal injury or death

3. Using the assembled guard as a template, locate, drill, & tap (4) 5/16-18 or other appropriately sized holes in the base. Reference dimensions: F, H, J1, J2, and K for layout.
4. Loosely attach the coupling guard to the base with (4) 5/16-18 Bolts or other appropriately sized fasteners.
5. Align the coupling guard along the drive axis of the pump's drive shaft/ coupling/ powerdrive to achieve the .25" (6,4 mm) maximum gap with the rotating equipment.
6. Tighten the (4) 5/16-18 Bolts or other appropriately sized fasteners to the base. See Table Below
7. Be sure ALL fasteners are tightened appropriately to prevent guard from vibrating loose during operation. See Table Below
8. Check for clearance by hand turning the rotating elements to check for rotating clearance (Reference dimension A). And alignment to the pump's drive shaft/ coupling/ powerdrive. Re-adjust Coupling guard as necessary. Follow Steps 1-2, 5-6.

Torque Table

| Bolt Size | Torque to |
|-----------|---------------------|
| ¼-20 | 100 in/lbs (11.3Nm) |
| 5/16-18 | 200 in/lbs (22.6Nm) |

AVAILABLE SIZES & ADJUSTMENT POINTS

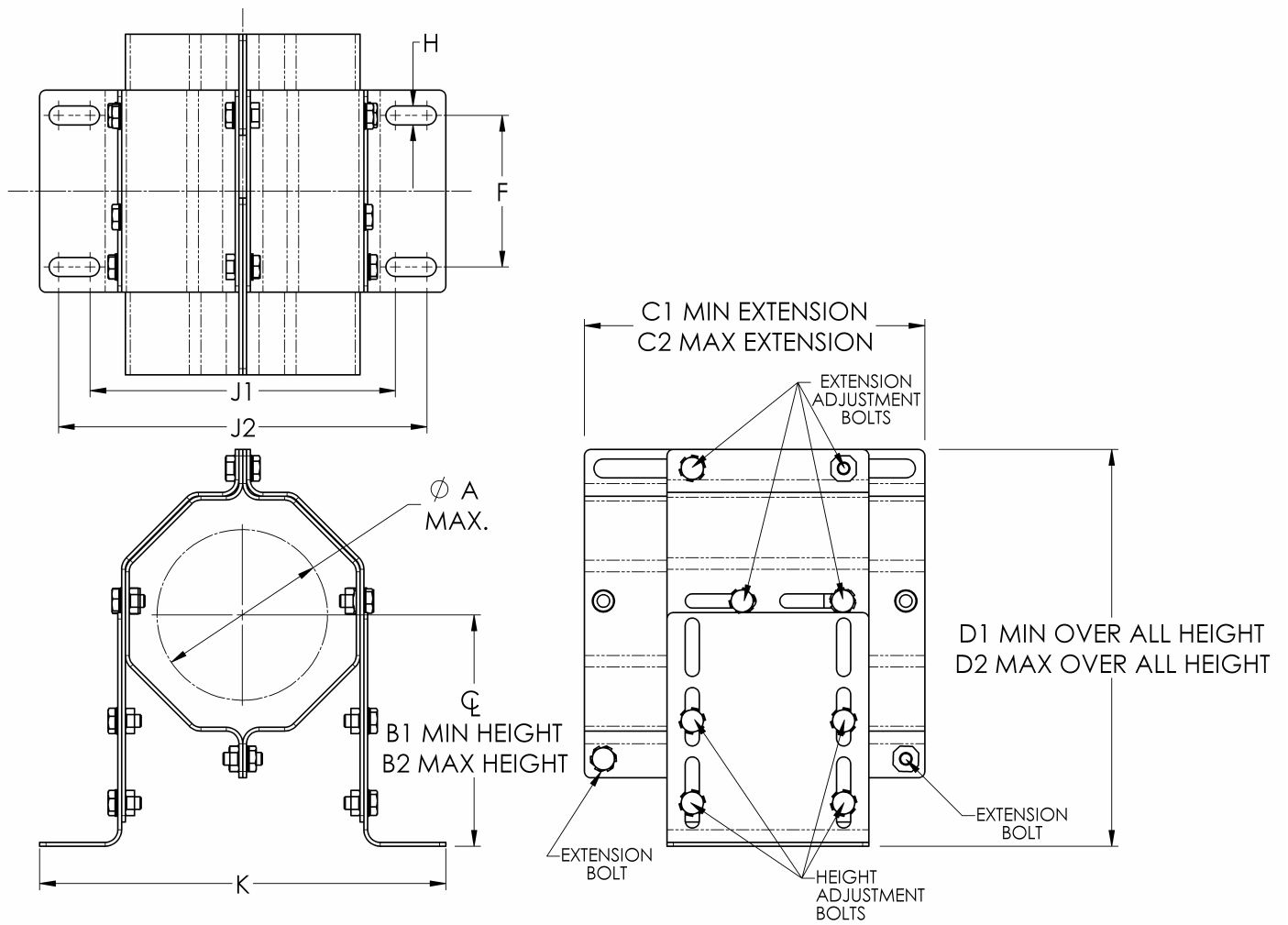

| Part Number | A | | B1 | | B2 | | C1 | | C2 | | D1 | | D2 | |
|-------------|------|-------|------|-------|------|-------|-------|-------|-------|-------|------|-------|-------|-------|
| | Inch | mm | Inch | mm | Inch | mm | Inch | mm | Inch | mm | Inch | mm | Inch | mm |
| 804147 | 3.38 | 85.7 | 4.63 | 117.5 | 8.13 | 206.4 | 4.00 | 101.6 | 6.25 | 158.8 | 7.88 | 200.0 | 11.38 | 288.9 |
| 804152 | | | | | | | 5.50 | 139.7 | 7.75 | 196.9 | | | | |
| 804148 | | | | | | | 7.00 | 177.8 | 9.25 | 235.0 | | | | |
| 804149 | 6.50 | 165.1 | 4.75 | 120.7 | 8.00 | 203.2 | 4.00 | 101.6 | 6.25 | 158.8 | 9.50 | 241.3 | 12.75 | 323.9 |
| 804151 | | | | | | | 5.50 | 139.7 | 7.75 | 196.9 | | | | |
| 804150 | | | | | | | 7.00 | 177.8 | 9.25 | 235.0 | | | | |
| 804153 | | | | | | | 10.50 | 266.7 | 12.75 | 323.9 | | | | |
| | F | | H | | J1 | | J2 | | K | | | | | |
| Part Number | Inch | mm | Inch | mm | Inch | mm | Inch | mm | Inch | mm | | | | |
| 804147 | 3.00 | 76.2 | 0.38 | 9.5 | 7.30 | 185.4 | 6.05 | 153.7 | 8.05 | 204.5 | | | | |
| 804152 | | | | | | | | | | | | | | |
| 804148 | | | | | | | | | | | | | | |
| 804149 | | | | | | | | | | | | | | |
| 804151 | | | | | | | | | | | | | | |
| 804150 | | | | | | | | | | | | | | |
| 804153 | | | | | | | | | | | | | | |

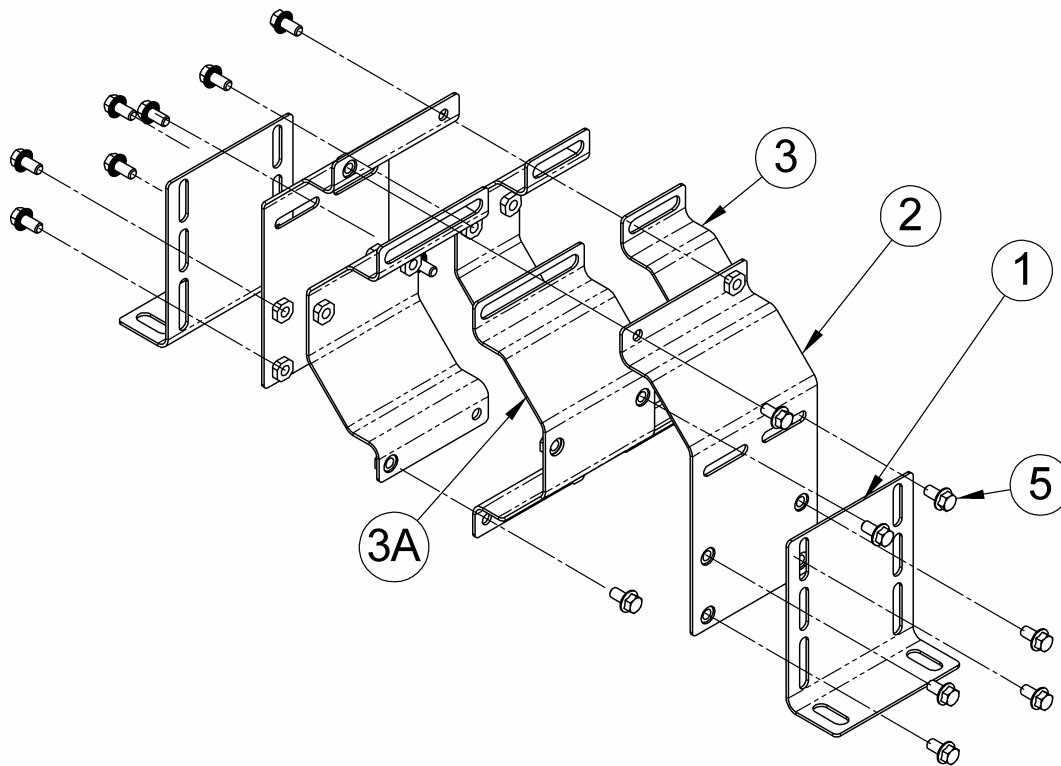

| Guard Number | | 804147 | 804148 | 804149 | 804150 | 804151 | 804152 | 804153 |
|--------------|--|---------------|---------------|---------------|---------------|---------------|---------------|---------------|
| Ref. No. | Part Name | Parts per Kit | Parts per Kit | Parts per Kit | Parts per Kit | Parts per Kit | Parts per Kit | Parts per Kit |
| 1 | Guard Foot | 2 | 2 | 2 | 2 | 2 | 2 | 2 |
| 2 | Guard Top | 2 | 2 | 2 | 2 | 2 | 2 | 2 |
| 3 | Short Extension | 4 | — | 4 | — | 2 | 2 | 2 |
| 3A | Long Extension | — | 4 | — | 4 | 2 | 2 | 2 |
| 5 | Guard Capscrew, flanged head ($\frac{1}{4}$ -20 x $\frac{1}{2}$ " Long) | 16 | 16 | 16 | 16 | 16 | 16 | 16 |
| 6 | Mounting Capscrew (not shown) ($\frac{5}{16}$ -18 x $\frac{7}{8}$ " Long) | 4 | 4 | 4 | 4 | 4 | 4 | 4 |

Note: Guards prior to August 2008 contained a Lockwasher with each Guard Capscrew.

The Coupling Guards are made in compliance with U.S. National Machine Safety Standards.
Reference: OSHA Std 1910.219 (1996), ASME B15.1 (2000), and ANSI Z535 (1998)

| PART NAME | STANDARD MATERIALS |
|---|---|
| Stamped Metal Parts | 14 gauge Steel with attached $\frac{1}{4}$ -20 tapped weld nuts |
| Guard Capscrews, flanged head ($\frac{1}{4}$ -20 x $\frac{1}{2}$ " Long) | Steel Grade 2, Zinc Plated |
| Mounting Capscrew ($\frac{5}{16}$ -18 x $\frac{7}{8}$ " Long) | Steel Grade 5 |

1809 Century Avenue, Grand Rapids, Michigan 49503-1530 U.S.A.
Telephone: (616) 241-1611 • Fax: (616) 241-3752
E-mail: blackmer @blackmer.com • Internet Address: www .blackmer.com