

BLACKMER LIQUEFIED GAS PUMPS

INSTALLATION OPERATION AND MAINTENANCE INSTRUCTIONS

MODELS: EBSRAY RC20, RC25, RC40

967010

INSTRUCTIONS NO. 551-A00

Section	551
Effective	Jul 2021
Replaces	Jul 2021

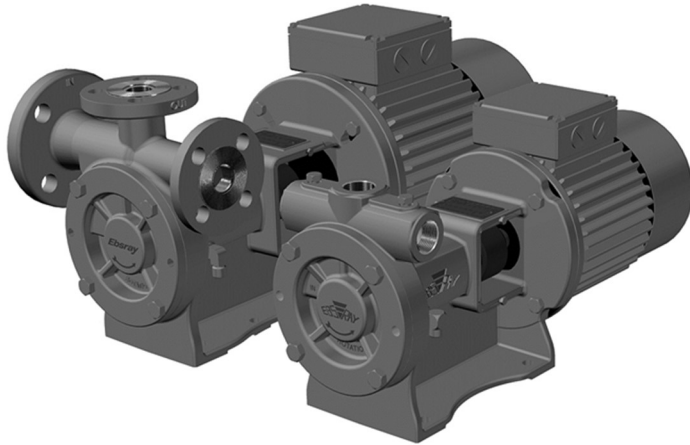

SAFETY DATA



This is a SAFETY ALERT SYMBOL.

When you see this symbol on the product, or in the manual, look for one of the following signal words and be alert to the potential for personal injury, death or major property damage



Warns of hazards that **WILL** cause serious personal injury, death or major property damage.



Warns of hazards that **CAN** cause serious personal injury, death or major property damage.



Warns of hazards that **CAN** cause personal injury or property damage.

NOTICE:

Indicates special instructions which are very important and must be followed.

TABLE OF CONTENTS

	Page
SAFETY DATA	1
PUMP DATA	2
Technical Data	2
GENERAL	
Important Notes	3
System Description	3
Ebsray RV18 Bypass Valve	3
INSTALLATION AND OPERATION	
Pre-Installation Cleaning	4
Location and Piping	4
Pump Mounting	4
Motor Mounting Flange	5
Couplings	5
External Bypass Valve	5
Check Valves	5
Pump Rotation	5
Commissioning, Start Up Procedure and Bypass Adjustment	6
MAINTENANCE	
Periodic Inspection	7
Strainers	7
Lubrication	7
Ball Bearings	7
Replace Mechanical Seal Only	8
Pump Disassembly	8
Inspection	8
Reassembly	9
PARTS DESIGNATION	11
TROUBLESHOOTING	12
TYPICAL INSTALLATION P&ID	15
PRE-STARTUP COMMISSIONING CHECKLIST	16
PUMP RUN LOG	17
DIMENSIONS	18

NOTICE:

Blackmer liquefied gas pumps **MUST** only be installed in systems which have been designed by qualified engineering personnel. The system **MUST** conform to all applicable local and national regulations and safety standards.

This manual is intended to assist in the installation and operation of the Blackmer liquefied gas pumps, and **MUST** be kept with the pump.

Blackmer liquefied gas pump service shall be performed by qualified technicians **ONLY**. Service shall conform to all applicable local and national regulations and safety standards.

Thoroughly review this manual, all Instructions and hazard warnings, **BEFORE** performing any work on the Blackmer liquefied gas pumps.

Maintain **ALL** system and Blackmer liquefied gas pump operation and hazard warning decals.

NOTE: Numbers in parentheses following individual parts indicate reference numbers on 'Parts List'.

Blackmer pump manuals and parts lists may be obtained from Blackmer's website (www.blackmer.com) or by contacting Blackmer Customer Service.

SAFETY DATA

⚠WARNING



Hazardous machinery can cause serious personal injury.

Failure to disconnect and lockout electrical power or engine drive before attempting maintenance can cause severe personal injury or death

⚠WARNING



Hazardous voltage. Can shock, burn or cause death.

Failure to disconnect and lockout electrical power before attempting maintenance can cause shock, burns or death

⚠WARNING



Hazardous pressure can cause serious personal injury or property damage

Disconnecting fluid or pressure containment components during pump operation can cause serious personal injury or property damage.

⚠WARNING



Hazardous pressure can cause serious personal injury or property damage

Failure to relieve system pressure prior to performing pump service can cause serious personal injury or property damage. Systems with meters will still be pressurized even after the hose is emptied

⚠WARNING



Hazardous or toxic fluids can cause serious injury.

If pumping hazardous or toxic fluids, system must be flushed and decontaminated, inside and out, prior to performing service or maintenance

⚠WARNING



Do not operate without guard in place

Operation without guards in place can cause serious personal injury, major property damage, or death.

PUMP DATA

PUMP IDENTIFICATION

A pump Identification tag, containing the pump serial number and model designation, is attached to each pump. It is recommended that the data from this tag be recorded and filed for future reference. If replacement parts are needed, or if information pertaining to the pump is required, this data must be furnished to a Blackmer representative.

TECHNICAL DATA

Maximum Pump Speed	3450 RPM
Maximum Differential Pressure	175 PSI (12.1 Bar)
Maximum Working Pressure	400 PSI (27.6 Bar)

INITIAL PUMP START UP INFORMATION

See 'SYSTEM PRE-STARTUP COMMISSIONING CHECKLIST'.

- Technical Data is for standard materials of construction. Consult Blackmer Material Specs for optional materials of construction.
- These pumps are listed by Underwriters' Laboratories for liquefied petroleum gas (LPG) service

GENERAL

IMPORTANT NOTES

1. This Publication is **TYPICAL ONLY** and only relates to the specifications of the minimum equipment required to ensure the optimum performance, maximum life and trouble-free operation of the Ebsray RC Series Pumps and the Pumping System in general.
2. This Publication does **NOT** depict:
 - a) Ancillary required equipment related to the fabrication, installation and operation of the Pumpset e.g. miscellaneous flanges, fittings etc.
 - b) Required equipment unrelated to the Pumpset e.g. tank fill lines, vapor return lines, emergency shutdown systems etc.
 - c) The materials and method of fabrication and/or installation of the tank and required sub-systems.
3. It is the responsibility of the designer, fabricator and the installer of each actual tank and required sub-systems to ensure that:
 - a) The Ebsray specifications within this Publication and any other relevant Ebsray documents are **STRICTLY** adhered to.
 - b) Any variation (including use of equipment deemed "Equivalent") or addition to the Ebsray Specifications, as related to the Pumpset and Pumping System in general, meet Ebsray's minimum requirements.
 - c) All design, fabrication and installation of the tank and sub-systems is **STRICTLY** in accordance with all relevant National, State and Local Codes, Regulations, Standards and Directives.

ABBREVIATIONS:

AFL	Automatic Fill Limiting Valve
CBS	Constant Bleed System
EFV	Excess Flow Valve
FLA	Full Load Amps
VRS	Vapor Removal System

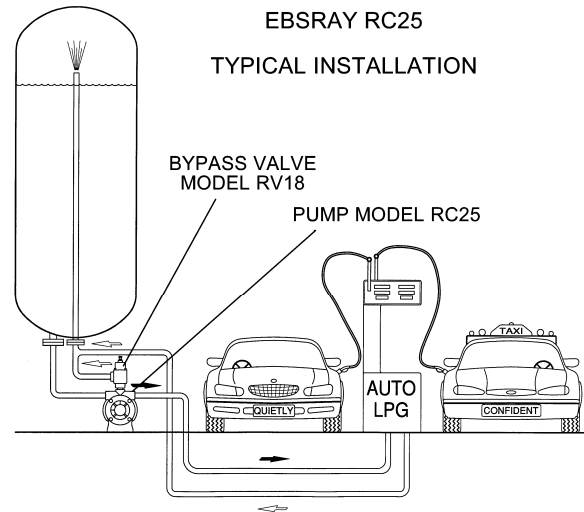

SYSTEM DESCRIPTION

Correct installation and operation is essential. Service life is enhanced by periodic inspection and careful maintenance.

The RC Series Pumps are designed generally for installation aboveground when connected to aboveground storage tanks. For Underground installations – consult the factory.

BYPASS VALVE – EBSRAY MODEL RV18

The RC Series Pumps must be installed in conjunction with a bypass valve - connected back-to-tank. The EBSRAY Model RV18 fitted with VRS or CBS option is recommended. (Refer to 'P&ID' schematic for details)

The Bypass Valve plays a pivotal role in the overall LPG system. It controls the following functions:

1. Maintains pump system differential pressure as required for optimum flow rates.
2. Controls Differential Pressure to maintain pump's and/or motor's correct operation within intended maximum operating parameters.
3. VRS option, when fitted, ensures rapid vapor passage for faster pump priming before acting in its intended liquid handling mode.

INSTALLATION

NOTICE:

Blackmer pumps must only be installed in systems designed by qualified engineering personnel. System design must conform with all applicable regulations and codes and provide warning of all system hazards.

NOTICE:

This pump shall be installed in accordance with the requirements of NFPA 58 all applicable local, state and national regulations.



- ⚠ Install, ground and wire to local and National Electrical Code requirements.
- ⚠ Install an all-leg disconnect switch near the unit motor.
- ⚠ Disconnect and lockout electrical power before installation or service
- ⚠ Electrical supply MUST match motor nameplate specifications.

⚠ Motors equipped with thermal protection automatically disconnect motor electrical circuit when overload exists. Motor can start unexpectedly and without warning.

PRE-INSTALLATION CLEANING

NOTICE:

New pumps contain residual test fluid and rust inhibitor. If necessary, flush pump prior to use.

Foreign matter entering the pump WILL cause extensive damage. The supply tank and intake piping MUST be cleaned and flushed prior to pump installation and operation.

NEVER allow water or any corrosive product to enter the pump (e.g. for hydrostatic testing of pipework). Severe internal damage may result.

LOCATION AND PIPING

Refer to 'P&ID' schematic for system arrangement and relative positions of important components/equipment.

Pump life and performance will be significantly reduced when installed in an improperly designed system. Before starting the layout and installation of the piping system, review the following suggestions:

1. Locate the pump as near as possible to the source of supply to avoid excessive inlet pipe friction.
2. The inlet piping and fittings should be at least as large as the intake port on the pump. It should slope downward to the pump, and should not contain any upward loops. Minimize the number of intake line fittings and eliminate restrictions such as sharp bends; globe valves, unnecessary elbows, and undersized strainers.
3. Protection from direct sun will enhance pumping performance by minimizing vaporization in pump and inlet pipe. Blackmer recommends that the pump and its inlet pipework are painted white.
4. A strainer must be installed in the inlet line to protect the pump from foreign matter. The strainer should be located at least 24" (0.6m) from the pump, and have a net open area of at least four times the area of the intake piping. Strainers must be cleaned regularly to avoid pump starvation. (Strainers are optional when pumping from underground tanks.)

5. The intake and discharge piping system must be free of all leaks.
6. Expansion joints, placed at least 36" (0.9m) from the pump, will compensate for expansion and contraction of the pipes. Contact the flexible connector/hose manufacturer for required maintenance/care and design assistance in their use.
7. ALL piping and fittings MUST be properly supported to prevent any piping loads from being placed on the pump.
7. Check alignment of pipes to pump to avoid strains which might later cause misalignment. See Figure 1. Unbolt flanges or break union joints. Pipes should not spring away or drop down. After pump has been in operation for a week or two, completely recheck alignment.

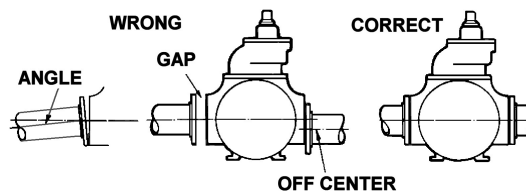

Figure 1

8. Install pressure gauges in the NPT ports provided in the pump casing to check pump performance at start up.
9. The use of a vapor return line will speed delivery by preventing pressure build up at the receiving tank and pressure reduction in the supply tank.
10. Keeping the liquefied gas systems full of liquid, even when idle, will keep the O-rings from changing shape, shrinking or super cooling. Evaporation of liquefied gas leaves an abrasive powder on the surface which can cause wear to the pump, meter, and seals.

PUMP MOUNTING

Permanently mount the unit by securing the base plate with adequately sized anchor bolts to a level concrete floor following recommended industry standards. A solid foundation will reduce system noise and vibration, and will improve pump performance. Refer to ANSI/HI standards or a suitable pump handbook for information on typical pump mounting and foundations. Check coupling alignment after pump and base assembly is secured to the foundation.

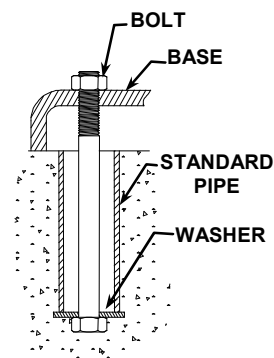

Figure 2. Foundation Anchor

When installing units built on channel or structural steel type bases, use care to avoid twisting the base out of shape when anchor bolts are tightened. Shims should be used under the edges of the base prior to tightening of the anchor bolts to prevent distortion.

Ensure floor area and headroom allotted is sufficient for inspection, maintenance and motor cooling airflow. Allow for crane or hoist access if require.

INSTALLATION

MOTOR MOUNTING FLANGE

These models incorporate a motor mounting flange that allows direct mounting to either a NEMA or an IEC flanged motor. See Dimensions page for details. If a footed motor is used, the motor must not be secured to baseplate.

COUPLINGS

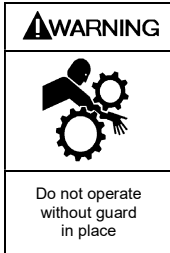

Operation without guards in place can cause serious personal injury, major property damage, or death.

Couplings must be of the non-sparking design and be in compliance with the relevant Directives, Standards, Codes & Regulations

The pump must be directly coupled to a driver with a flexible, non-sparking coupling. Verify the coupling gap per the Dimension page after installation of new or rebuilt pumps. Replace the coupling guards after checking the gap.

EXTERNAL BYPASS VALVE

For ALL liquefied gas applications, install an external bypass valve, and any necessary piping, back to the storage tank. DO NOT pipe the bypass valve back to the intake line.

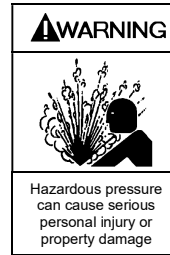

Bypass valve shall be sized and adjusted so the maximum pressure of the system does not exceed the lowest service pressure rating of any component used in the delivery system.

Bypass Valve (Ebsray Model RV18-VRS or CBS) (Refer 'P&ID' schematic for details) is installed on the pump discharge side and returns back-to-tank. It may be mounted directly on the 'spare' discharge port or in the discharge pipe (before any isolation valve). This Bypass Valve is primarily for control of differential pressure. (NOTE: Variation in tank vapor pressure has a direct effect upon discharge pressure whilst constant differential pressure is maintained).

Ensure correct orientation i.e. flow is 'IN' from pump discharge line and 'OUT' returns to tank.

The Bypass Valve's return-to-tank pipeline MUST NOT have any restrictions which could adversely affect, limit or block the unrestricted the vapor clearing function during pump priming.

Flow of LPG during bypassing should return to Storage Tank vapor space.

An Excess Flow Valve or other 'normally open' tank valve is recommended.

CHECK VALVES

A 'soft-seat' check valve in the discharge line is recommended, particularly if the discharge line is over 100 ft (30 m). Refer to 'P&ID' schematic for system arrangement.

The use of check valves or foot valves in the supply tank is not recommended.

PUMP ROTATION

The proper rotation direction is indicated on the pump cover and cannot be changed.

NOTICE:

Confirm correct pump rotation by checking the pump flow / rotation arrows respective to pump driver rotation. Do not operate the pump at the wrong rotation.

OPERATION

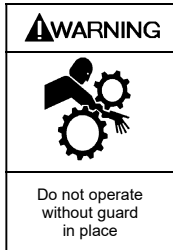

Operation without guards in place can cause serious personal injury, major property damage, or death.

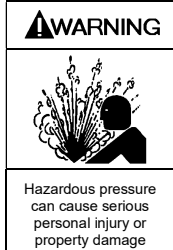

Failure to relieve system pressure prior to performing pump service can cause serious personal injury or property damage. Systems with meters will still be pressurized even after the hose is emptied

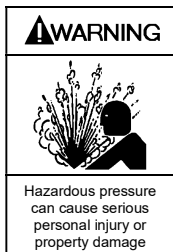

Disconnecting fluid or pressure containment components during pump operation can cause serious personal injury or property damage.

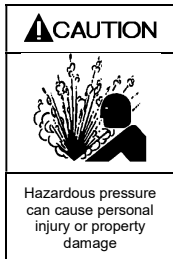

Pumps operating against a closed valve can cause system failure, personal injury and property damage

COMMISSIONING START-UP PROCEDURE and BYPASS ADJUSTMENT

NOTICE

Do not run the Pump dry. Do not start the Pump against closed Discharge Valve. Severe internal damage to the Pumpset will result.

1. Ensure all conditions described in Pre-Start-Up Checklist have been met. Fill in the 'Pump Run Log'.
2. Check reading on discharge pressure gauge. Record product vapor pressure in the commissioning section of the Pump Run Log.
3. To increase bypass pressure, rotate Adjusting Screw in clockwise direction (i.e. screw in).
To decrease bypass pressure, rotate Adjusting Screw anti-clockwise (i.e. screw out).
4. Ensure that there is an appropriate pressure gauge fitted to Pumps' main discharge viewable while setting the Bypass Valve

5. Rotate the Bypass Adjusting Screw anti-clockwise until there is no resistance against the screw. This is the Bypass Valve's minimum pressure setting.
6. Ensure that the system is set such that 100% of the Pump's flow is directed through the Bypass Valve
7. Briefly activate power (i.e. 'jog' motor) to verify correct pump rotation. (Cast arrow on Cover).
8. Start the Pump and ensure that liquid is flowing through Bypass Valve. This should be detectable audibly (by listening) or by feeling the valve/pipework by hand.
9. After start-up, pump should immediately begin to build differential pressure. If pump does not prime immediately, switch off to determine reason and rectify before re-starting.
10. Screw in the Bypass Valve Adjusting Screw, not exceeding two turns per minute until the desired differential pressure is reached.
11. While retaining the Adjustment Screw, lock the Adjusting Screw Lock Nut against Bypass Valve Cover immediately after adjustment is made.
12. After the setting of the Bypass Valve is completed, wire and seal Adjusting Screw, utilizing holes provided for passing wire through head of Adjusting Screw and lug on Bypass Valve Cover.

NOTE: Bypass Valves characteristically exhibit two distinct pressures during their operation:

- a) The 'setting' or 'cracking' pressure which occurs when the Bypass Valve first opens i.e. initial bypassing begins against the preset spring load, and;
 - b) 'Maximum' pressure, which occurs when the full flow of the bypassed product passes through the Bypass Valve.
- It is important to ensure both of these characteristics are understood fully in order to correctly apply the Bypass Valve.

NOTICE:

If any aspect of the Pump or pumping system does not function properly, immediately turn the pump 'off' and rectify the problem before re-starting.

13. Record discharge pressure in the commissioning section of the Pump Run Log.
14. Check that motor current is below FLA rating. Record the motor current readings in the commissioning section of the Pump Run Log. **During this procedure, or at any time, motor current must not exceed FLA rating of motor.**
15. Stop pump, restart and check for consistent results, rectify if required.
16. Record discharge pressure and current readings in the commissioning section of the Pump Run Log.
17. Inspect Pumpset/pumping system frequently during the first few hours of operation then periodically thereafter (see 'Periodic Inspection'). Record the observations from these inspections in the Pump Run Log.

MAINTENANCE

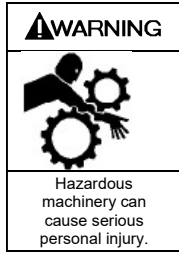

Failure to disconnect and lockout electrical power or engine drive before attempting maintenance can cause severe personal injury or death

Hazardous machinery can cause serious personal injury.

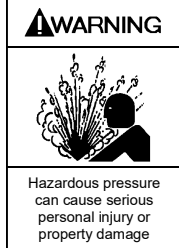

Disconnecting fluid or pressure containment components during pump operation can cause serious personal injury or property damage.

Hazardous pressure can cause serious personal injury or property damage

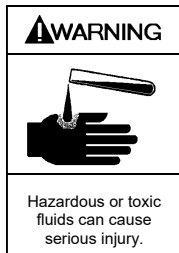

If pumping hazardous or toxic fluids, system must be flushed and decontaminated, inside and out, prior to performing service or maintenance

Hazardous or toxic fluids can cause serious injury.

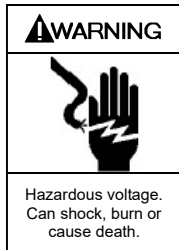

Failure to disconnect and lockout electrical power before attempting maintenance can cause shock, burns or death

Hazardous voltage. Can shock, burn or cause death.

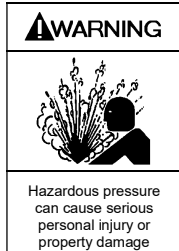

Failure to relieve system pressure prior to performing pump service can cause serious personal injury or property damage. Systems with meters will still be pressurized even after the hose is emptied

Hazardous pressure can cause serious personal injury or property damage

Periodic Inspection

Periodic Inspection of the Pump, Pump System and Ancillary Equipment is required to maintain safety, conformity, operational functionality and reliability. Blackmer recommends a maximum interval of three months or 500 hours operation between routine periodic maintenance inspections (More frequent inspections may be necessary dependent upon usage, site conditions, operation, etc.).

If any abnormal condition is discovered, cease operation of pump immediately and take action to rectify the problem. Record observations from these inspections in Pump Run Log.

For safe operation, the following items should be included in the routine periodic inspection:

- Inspect the Pump for LPG leaks, vibration, abnormal noises, signs of overheating, discoloration, etc.
- Inspect Coupling Assembly for signs of wear, overheating, discoloration, etc.
- Check Pump differential pressure
- Check Motor Current.
- Inspect motor for vibration, abnormal noises, signs of overheating, discoloration, etc.

STRAINERS

Strainers must be cleaned regularly to avoid pump starvation. Schedule will depend upon the application and conditions.

LUBRICATION

The Ball Bearings for the RC Series pumps are grease lubricated and 'sealed-for-life' design.

No 'in service' lubrication is required on Ebsray's RC Series Pumps.

For motor, refer to specific motor manufacturer's recommendations.

BALL BEARINGS

Bearing Replacement recommended not exceeding 10,000 operational hours.

NOTICE:

Maintenance shall be performed by qualified technicians only, following the appropriate procedures and warnings as presented in this manual.

MAINTENANCE

NOTICE:

Maintenance shall be performed by qualified technicians only, following the appropriate procedures and warnings as presented in this manual.

Most maintenance tasks and inspections can be performed with the pump 'in line' so long as complete electrical isolation, depressurizing and purging procedures have been completed.

TO REPLACE MECHANICAL SEAL ONLY

1. Follow steps 3, 4, 6, and 7 in PUMP DISASSEMBLY.
2. Inspect relevant components as described in 'INSPECTION' and repair or replace as required.
3. Follow steps 1 to 6 in 'PUMP ASSEMBLY'.
Fit Cartridge to Body before fitting and securing Mechanical Seal Assembly as shown in Fig 13
Then follow steps 14 to 16 in 'REASSEMBLY'.

PUMP DISASSEMBLY

NOTICE:

Follow all hazard warnings and instructions provided in the "Pump Maintenance" section of this manual.

Refer to 'PARTS DESIGNATION'

1. Drain and relieve pressure from the pump and system as required.
2. Remove Motor, Coupling Guards (37), Pump Coupling half (36P) and Pump Shaft Key (34).
3. Remove Cover (2), Impeller (3) and Impeller Key (8). The Coupling Guard retaining screws (37A) may be screwed into the Impeller to aid removal.
4. Fig. 2
Unscrew four setscrews (57A) from Cartridge (57).
5. Insert setscrews into the two extraction holes and screw in evenly to extract the Shaft Assembly.

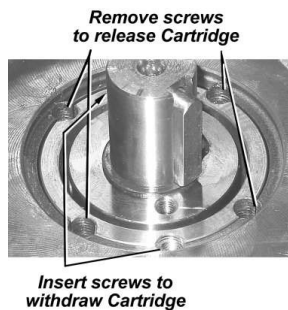
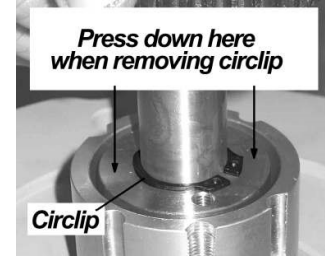

Fig 3
Complete Shaft Assembly

6. Fig. 4
Remove Circlip (58) from end of Shaft Assembly.
Remove Mechanical Seal Assembly (56). The Coupling Guard retaining screws (37) may be screwed into the Impeller and/or Seal Assembly to aid removal.



7. Fig 5
Remove Carbon Seal Seat (40) and Lip Seal (55) from Cartridge.



8. Remove Circlip (25) and press Bearings (23, 24) from Shaft.
9. Remove Dust Seal – Bearing (33) from Body.

INSPECTION

1. Fig. 6
Check Impeller and Seal Zone of Body for damage or wear. Replace Impeller if blades have been damaged or wear exceeds minimum recommended dimensions.

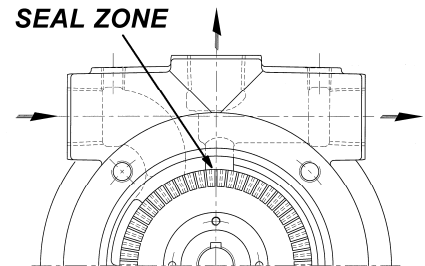

MINIMUM IMPELLER DIMENSIONS

Pump Model	RC20	RC25	RC40
Minimum worn width	0.349" 8.86 mm	0.388" 9.86 mm	0.585" 14.86 mm
Minimum worn diameter	4.325" 109.86 mm	4.325" 109.86 mm	4.640" 117.86 mm

2. Check Shaft (21) for wear, damage or run-out. Replace as required.
3. Inspect both Ball Bearings (23, 24) for wear. It is recommended on major overhauls that Ball Bearings be replaced. **Bearing Replacement recommended not exceeding 10,000 operational hours.**
4. Check Mechanical Seal components for wear or damage. It is recommended on major overhauls that Mechanical Seal components be replaced.
5. It is recommended that all O-Rings be replaced at every overhaul or when any disassembly is conducted.

MAINTENANCE

PUMP ASSEMBLY

Refer to 'PARTS DESIGNATION' for ref. numbers.

1. Ensure all parts are clean before assembly. Remove any burrs.
2. Ensure Impeller maintains an accurate free sliding fit on Shaft and key. **This is critical.**
3. Lightly lubricate O-Rings, Lip Seals and Mechanical Seal Faces with a compatible good quality detergent-free light oil before assembly.

NOTICE:

At all times when handling and installing mechanical seals, care must be taken to ensure lapped faces and seats are not damaged. Particular attention must be given to carbon seats to prevent marking or chipping.

Torque Table 1

Head / Casing Capscrews (6)	Ft-lbs	63
	N-m	85
Motor Capscrews - 3/8" (29)	Ft-lbs	12
	N-m	16
Motor Capscrews - 1/2" (29)	Ft-lbs	28
	N-m	38

4. Fig 7
Fit Lip Seal (55) to Cartridge.
Note position of lip.



5. Fig 8
Fit O-Ring (48) to Seal Seat (40).
Fit Seal Seat to Cartridge (57).



6. Fig 9
Press Seal Seat in with fingers.
Ensure complete and square engagement.



7. Fig 10
Fit Primary O-Ring (57B) to Cartridge (57) then fit Secondary O-Ring (57C).



8. Fig 11
Fit IE Bearing (23) to Shaft. **This is an interference fit. Apply force to inner race of Bearing only.**
Lock Bearing in position with Circlip (25)



9. Fig 12
Fit DE Bearing (24) to Shaft. **This is an interference fit. Apply force to inner race of Bearing only.**



10. Fig 13
Fit Bearing/Shaft Assembly into Cartridge (57).
Align the Drive Pin to the Keyway and fit Seal rotating subassembly (41, 42, 45, 46, 47) to Cartridge/Shaft Assembly.

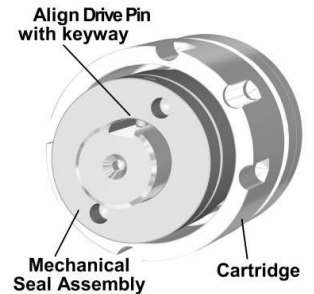

11. Fig 14
Press down and lock in position with Circlip (58).

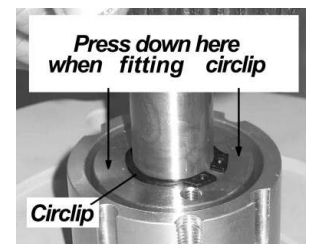

12. Fig 16
Fit Dust Seal (33) to Body.
Note position of lip.



MAINTENANCE

13. Fig 16

Lightly lubricate the bore in cartridge zone with a compatible good quality detergent-free light oil and fit Shaft Assembly to Body.

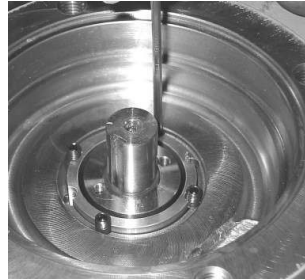

14. Lock in place with 4 setscrews (57A). Apply Loctite 243 or equivalent to setscrews

15. Fig 17

Fit Key (8) and Impeller (3). Ensure Impeller maintains an accurate free sliding fit on Shaft and Key. **This is critical**



16. Fig 18

Fit O-Ring (4) to Cover (2) and fit Cover to Body (1). Tighten bolts (6) to required torque per the Torque table.



17. Fig 19

Fit Key (34) and Coupling half to Pump. Apply Loctite 243 or equivalent to setscrews. Tighten setscrews.



18. Check for free rotation by hand rotating the Coupling half/shaft.

19. Fit Key and Coupling half to Motor. Apply Loctite 243 or equivalent to setscrews. Tighten setscrews. **Refer to 'Dimensions' for dimensions.**

20. Fit Coupling Guards.

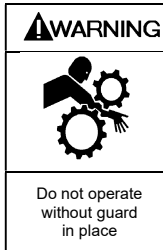

WARNING

Operation without guards in place can cause serious personal injury, major property damage, or death.

Do not operate without guard in place

21. Refer to "Pre-Start Up Check List" and "Start Up Procedures" sections of this manual prior to restarting pump operation.

EBSRAY MODELS: RC20 & RC25

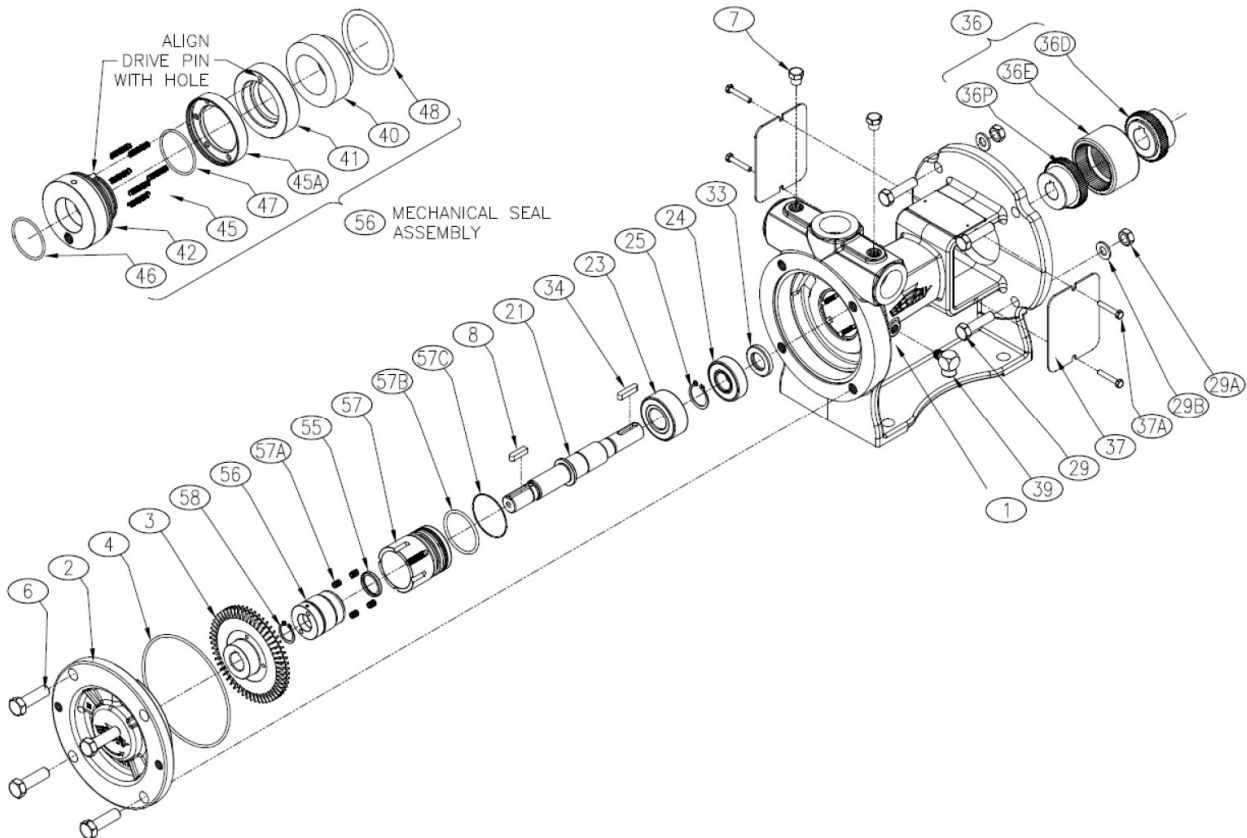

EBSRAY MODELS: RC40

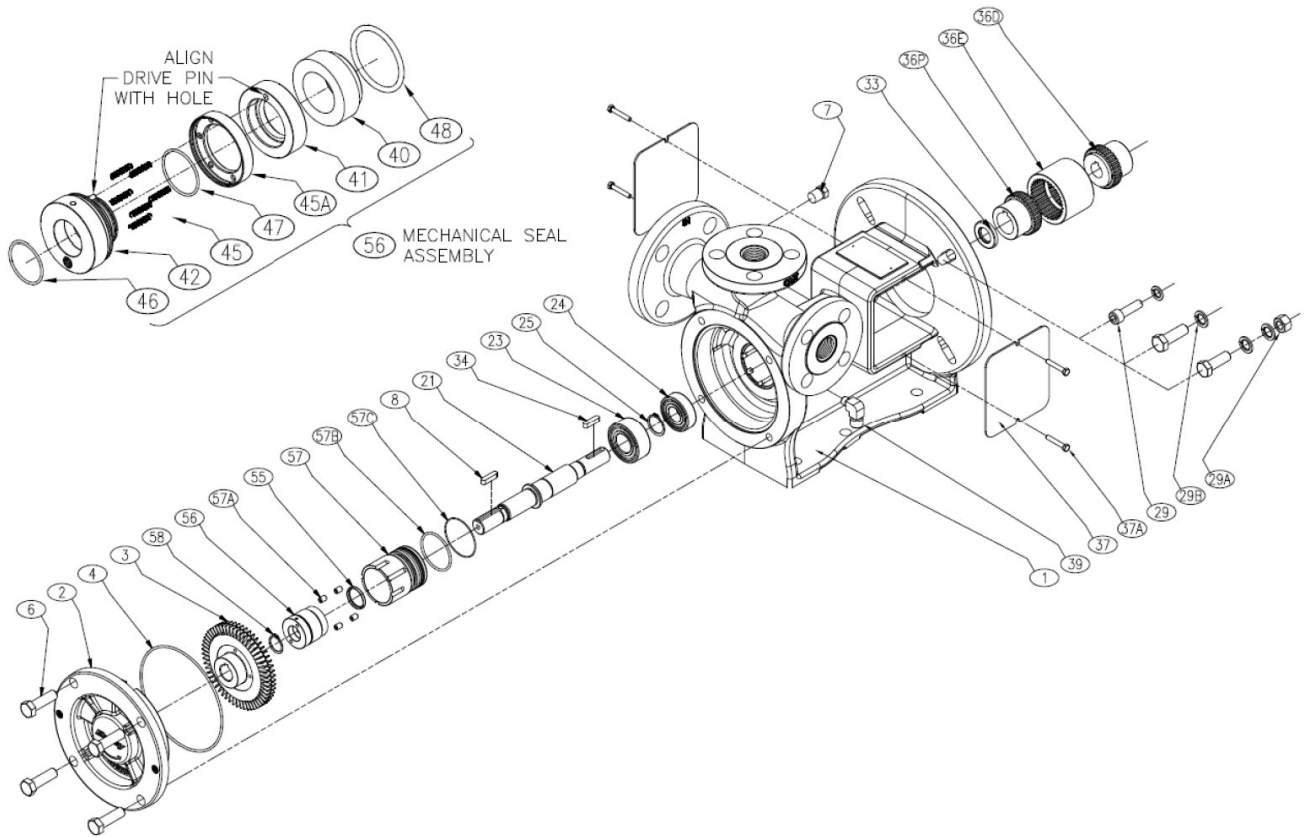

PARTS LIST – EBSRAY MODELS: RC20, RC25 & RC40

Cat #	Description	Qty	RC20	RC25	RC40
1	Body - NEMA	1	EBSC317002-1031	EBSC316003-1031	EBSC319001-1037
2	Cover	1	EBSC317200-1031	EBSC316200-1031	EBSC319200-1037
3	Impeller	1	EBSC317301-1042	EBSC316301-1042	EBSC319301-1042
4	O-Ring – Cover	1	¹ EBSD249-4029		¹ EBSD252-4029
6	Hex Head Capscrew, M12-1.75x40	4			
7	Plug –Gauge Tap	2	BLK908198		
8	Key – Impeller, Steel 6x6x20	1			
21	Shaft	1	² EBSC316350-2152		² EBSC319350-2152
23	Ball Bearing – Impeller End	1	² EBSB072		
24	Ball Bearing – Motor End	1	² EBSB073		
25	Circlip – Bearing	1	² EBS8177-025S		
33	Dust Seal - Bearing	1	EBSZ044-4011		
34	Key – Pump Shaft, Steel 6x6x20	1			
36	Coupling Assembly - 0.875 Motor Shaft, NEMA 140TC, 184C	1	EBSL575-028-019-087		
	Coupling Assembly - 1.125 Motor Shaft, NEMA 180TC, 215C	1	EBSL575-028-019-306		EBSL575-038-019-306
	Coupling Assembly - 1.375 Motor Shaft, NEMA 213TC, 215TC	1			EBSL575-038-019-297
	#36D Half Coupling – 0.875 Motor Shaft	0-1			
	#36D Half Coupling – 1.125 Motor Shaft	0-1			
	#36D Half Coupling – 1.375 Motor Shaft	0-1			
	#36E Coupling Element	1			
#36P Half Coupling – Pump	1				

Cat #	Description	Qty	RC20	RC25	RC40
37	Coupling Guard	2	EBSC316700-3081		EBSC319700-3081
37A	Hex Head Capscrew – Coupling Guard, M5-0.8x30	4			
39	Seal Drain Elbow	1	EBS-8312-012S		
55	Lip Seal - Secondary Seal	1	² EBSZ043-4015		
56	Mechanical Seal Assembly	1	^{1,2} EBSL756-28-111-05		
40	Seal Seat	1	EBSC316610-4114		
41	Rotating Seal Face	1	EBSC316626-4036		
42	Seal Sleeve	1	EBSC316651-2162		
45	Seal Spring	6	EBSC753001-2223		
45A	Spring Retainer	1	EBSC316690-2162		
46	O-Ring – Shaft	1	EBSD020-4029		
47	O-Ring – Seal Sleeve	1	EBSD020-4029		
48	O-Ring – Seal Seat	1	EBSD218-4029		
57	Cartridge - Mechanical Seal	1	² EBSC316676-1035		
57A	Oval Point Setscrew, 1/4-28x0.375	4			
57B	O-Ring – Cartridge Primary	1	^{1,2} EBSD224-4029		
57C	O-Ring – Cartridge Secondary	1	^{1,2} EBSD032-4029		
58	Circlip - Mechanical Seal	1	² EBS8177-020S		
	Mechanical Seal Kit, Repair (Marked by ¹)	1	EBSK756-28-111		
	Quill Assembly, (Marked by ²)	1	EBSL316378		EBSL319378

RC20/RC25

Motor Attachment - NEMA 140TC, 184C		
29	Hex Head Capscrew - 0.375-16 x 1.50	4
29B	Spring Lock Washer - 0.375	4
Motor Attachment - NEMA 180TC, 215C		
29	Hex Head Capscrew - 0.500-13 x 2.00	4
29B	Spring Lock Washer - 0.500	4

RC40

Motor Attachment – NEMA 213TC/215TC		
29	Hex Head Capscrew – 0.500-13 x 2.00	4
29B	Spring Washer – 3/8" UNC	4

SPARE PARTS

1. When ordering spare parts, **ALWAYS** quote the pump Serial Number located on the nameplate of the pump.

TROUBLESHOOTING

NOTICE:

Maintenance shall be performed by qualified technicians only, following the appropriate procedures and warnings as presented in this manual.

Symptom	Possible Problem	Possible Cause	Remedy
Pump running but will not generate adequate differential pressure	Pump not primed	Insufficient LPG in Storage tank	Fill Storage tank
		Inlet Valve not open	Open Inlet Valve
		Excessive heating (sun) on inlet piping and/or Pump	Cover Pump/piping with sunshade Paint Pump/piping white
		Pump unable to clear vapor due to excessive restriction in Bypass return-to tank line	Ensure unrestricted and fully open passage back to tank, clear blockage and/or restrictions
		Excessive volume of vapor to be cleared	Inlet (suction) pipe too long/too large – Shorten/reduce diameter
		Storage tank filling by tanker during dispensing/pumping operation	Wait until filling operation is completed and mix/temp/state has stabilized in tank
		Normal wear after extended service	Service Pump
	Incorrect pump rotation	Incorrect wiring to Motor	Reverse rotation by rewiring Motor
Pump will not run	Dispenser/Control/Communications System faulty	Control System not providing signal	Repair Control System as required
	Power Supply faulty	Supply Power to Motor faulty	Check Power Supply
		Contact(s) or Coil in Motor Contactor faulty	Check Contactor, repair or replace as required
	No power to Motor	Motor Overload tripped out	Determine cause of trip-out before resetting
Jammed Pump	See Symptom 'Pump Motor using excessive power'		
Pump Motor using excessive power or over- heating	Differential Pressure too high	Incorrect Bypass Valve Setting.	Adjust (decrease) Bypass Valve setting to achieve required lower pressure.
		Discharge Valve not fully open	Open Discharge Valve
	Power Supply to Pump Motor faulty	Power Supply (incorrect voltage, phase imbalance or phase loss etc.)	Check Power Supply (with Pump running and with Pump stopped): a) To Main Switch Board b) To Pump Motor
	Pump jammed or damaged internally	Dirt/debris/contaminate from Storage Tank and/or inlet pipe	Clean blockage from Pump, Storage tank and/or inlet pipe before restarting Pump
		Impeller Damaged	Replace Impeller and inspect for damage to Body, Cover and Shaft.
	Motor rapid cycling	Excessive starts per hour (refer motor manufacturer)	Inspect, repair or replace motor. Limit starts per hour

TROUBLESHOOTING

Symptom	Possible Problem	Possible Cause	Remedy
Discharge Pressure too low	Differential Pressure too low	Insufficient LPG in Storage Tank	Fill Storage Tank
		Incorrect Bypass Valve setting.	Adjust (Increase) Bypass Valve setting to achieve required Differential Pressure.
		Bypass Valve jammed open or faulty	Check Bypass Valve, remove any obstruction, roughness, corrosion etc.
		Pump has 'Dead Headed' -Restriction in discharge system or Bypass line e.g. Discharge isolation valve, Bypass Valve, Bypass EFV or Isolation Valve closed	Check all devices in the discharge system and bypass line, remove blockage, repair or replace as required
		Excessive inlet (suction) restriction - Inlet Valve not opened fully - Blocked inlet strainer - Faulty Inlet Excess Flow Valve	Check / open Inlet Valve Clean strainer Check, repair or replace Inlet Excess Flow Valve as required
		Storage tank filling by tanker during dispensing/pumping operation	Wait until filling operation is completed and mix/temp/state has stabilized in tank
		Normal wear after extended service	Service Pump
		Discharge Valve not fully open	Open Discharge Valve
	Low vapor Pressure in Storage Tank	High% Butane in Storage tank	Increase Differential Pressure
			Increase Vapor Pressure
No Tank/Vehicle fill	Pump operating (rotating) but fails to deliver LPG	Receiving Tank/Vehicle Tank already full	No problem exists
		Insufficient LPG in Storage Tank	Fill Storage Tank
		Blockage in Pump inlet/discharge line	Clear blockage e.g. open Valve, Excess Flow Valve, Valve at Dispenser etc.
		Insufficient system Discharge Pressure (See Symptom "Discharge Pressure too low")	Increase Discharge Pressure (See Symptom "Discharge Pressure too low")
		Excessive pressure in Receiving Tank/Vehicle Tank	Allow Receiving Tank/Vehicle Tank to cool until pressure decreases
		Malfunctioning AFL Valve or blocked Filter in AFL Valve in Receiving Tank/Vehicle	Repair, clean filter or replace AFL Valve in Receiving Tank/Vehicle as required
		Blocked Filter in Meter/Dispenser	Check and clean or replace as required
		Blocked Filter in Nozzle	Check and clean or replace as required
		Pump not primed with LPG	Refer to Symptom "Pump running but will not generate adequate differential pressure" Section of this manual
		Storage tank filling by tanker during dispensing/pumping operation	Wait until filling operation is completed and mix/temp/state has stabilized in tank
		Dispenser malfunctioning or not authorized correctly	Re-authorize or check Dispenser as required.

TROUBLESHOOTING

Slow Tank/Vehicle fill	Low Pump flow	Insufficient LPG in Storage Tank - Pump Inlet (Suction) Port not fully covered with liquid	Fill Storage Tank
		Excessive pressure in Receiving Tank/Vehicle tank	As filling proceeds, temperature (and pressure) will fall - increasing fill rate
	Low Discharge Pressure	(See Symptom "Discharge Pressure too low")	(See Symptom "Discharge Pressure too low")
	Restriction between Pumpset and Vehicle tank	Malfunctioning AFL Valve or blocked filter in AFL Valve in Receiving Tank/Vehicle	Repair, clean filter or replace AFL Valve in Receiving Tank/Vehicle as required
		Blocked filter in Meter/Dispenser	Check and clean or replace as required
		Blocked filter in Nozzle	Check and clean or replace as required
		Blockage within Receiving Tank/Vehicle's fill piping or Receiving Tank/Vehicle Back-check valve faulty	Clear blockage. Check, clean or replace as required
	Excessive System resistance to flow	Long discharge line and/or small diameter	Increase diameter or increase differential pressure
		Blocked filters in discharge system	Clean filters
		High pressure drop equipment in discharge system (e.g. nozzle, dispenser, AFL valve, vehicle pipework)	Select 'lower loss' equipment
Excessive Noise and/or Vibration	Obstruction in Pump	Dirt/debris/contaminate in Pump	Clean blockage from Pump, Storage tank and/or inlet pipe before restarting Pump
	Faulty EFV on inlet, Bypass or Discharge	EFV Spring faulty or EFV ports partially blocked	Check EFV(s), repair or replace as required
	Faulty Back-check Valve in Discharge Line	Inspect Back-check Valve: Spring, Seat, Poppet, Flapper etc.	Repair or replace Back-check Valve as required
	Faulty/noisy Bypass Valve	Bypass Valve faulty, worn or damaged	Check Bypass Valve, adjust, repair or replace as required
	Motor / Pump ball Bearings worn	Normal wear after extended service	Service Pump/motor
"Pulsing" flow or Pump losing prime	Pump cavitating or drawing vapor	Insufficient LPG in Storage tank - Pump Inlet (suction) Port not fully covered with liquid	Fill Storage tank
		Excessive Inlet (suction) restriction - Inlet Valve not opened fully - Faulty Inlet Excess Flow Valve - Blocked inlet strainer	Check / Open Inlet Valve, repair or replace Excess Flow Valve as required Clean strainer
		Pump has 'Dead Headed' - Restriction in discharge system or Bypass line e.g. Discharge isolation valve, Bypass Valve, Bypass EFV or Isolation Valve closed	Check all devices in the Discharge Line or the Bypass Line, remove blockage, repair or replace as required
	Worn Pump	Normal wear after extended service	Service Pump

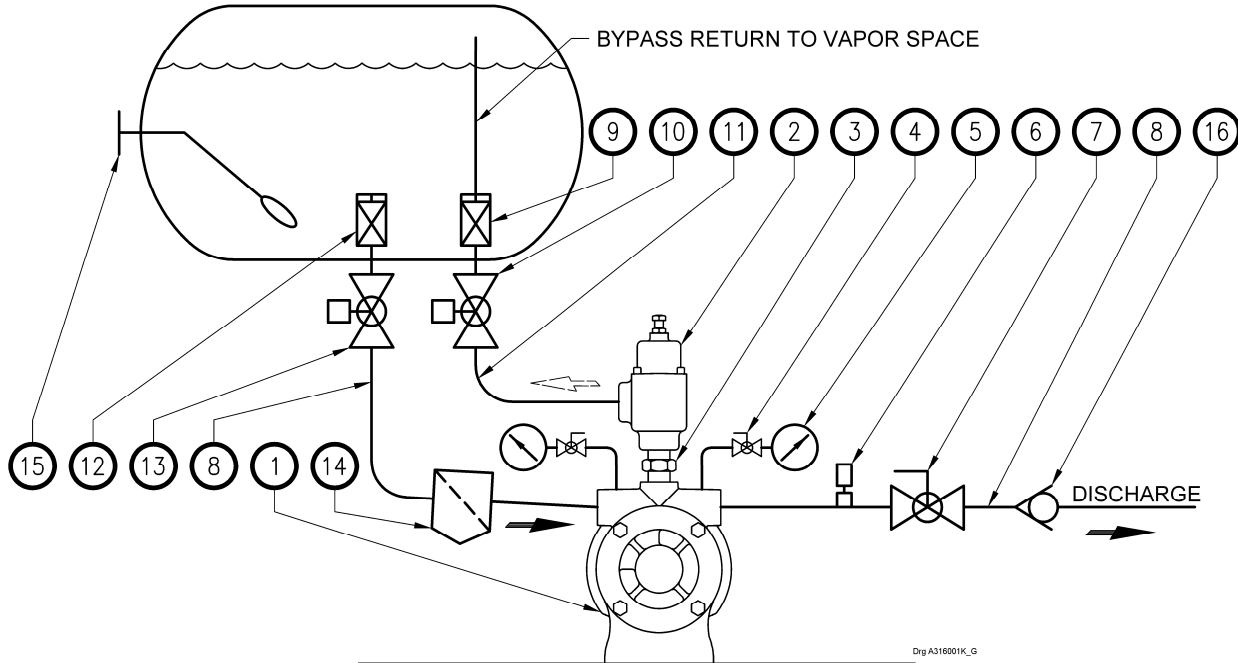

TYPICAL INSTALLATION P&ID – (ABOVEGROUND)

IMPORTANT NOTES

1. This P&ID is TYPICAL and only relates to the specification of the minimum equipment required to ensure the optimum performance, maximum lif and trouble-free operation of the Ebsray RC20/RC25 pumps and the pumping system in general.
2. The P&ID does NOT depict:
 - 2.1. Ancillary required equipment related to the fabrication, installation and operation of the pumpset, e.g. misc. flanges, fittings, etc.
 - 2.2. Required equipment unrelated to the pumpset, e.g. tank fill lines, vapor return lines, emergency shutdown systems, etc.
 - 2.3. The materials and method of fabrication and/or installation of the tank and required sub-systems.
3. It is the responsibility of the designer, fabricator and installer of each actual tank and required sub-systems to ensure that:
 - 3.1. All design, fabrication and the installation of the tank and required sub-systems is STRICTLY in accordance with all relevant Federal, State and Local Codes, Regulations and Standards.
 - 3.2. The Specifications with this P&ID and any other relevant Blackmer/Ebsray documents are STRICTLY adhered to.
 - 3.3. Any variation (including the use of equipment deemed "equivalent") or addition to the Blackmer/Ebsray Specifications as related to the pumpset and the pumping system in general, meet Blackmer/Ebsray's minimum requirements.

Ref	Description	Qty	Ref	Description	Qty
1	Ebsray RC20/RC25/RC40 pumpset	1	9	Excess flow valve for bypass return (<u>Not</u> non-return valve)	1
2	Ebsray RV18 bypass valve (See table)	1	10	3/4" (Min) Full bore pneumatic/solenoid actuated ball valve	1
3	1" NPT Schedule 80 hex nipple	1	11	3/4" (Min) Schedule 80 pipe (Bypass return to tank)	1
4	Isolation valve	2	12	Excess flow valve (Pump inlet)	1
5	Pressure gauge	2	13	1" (Min) Full bore pneumatic/solenoid actuated ball valve	1
6	Hydrostatic relief valve	1	14	Adequately sized inline strainer	1
7	1" (Min) Ball valve	1	15	Liquid level gauge/alarm	1
8	1" (Min) Sched 80 pipe (inlet and discharge)	1	16	1" (Min) 'Soft seat' back check valve	1

Ebsray Pump Model	Flow at Maximum Differential Pressure	Ebsray Bypass Valve
RC20 50 Hz / 2 Pole	4 gpm at 152 psid Max (16 lpm at 1,050 kPa)	RV18CBS2
RC20 60 Hz / 2 Pole	5 gpm at 203 psid Max (19 lpm at 1,400 kPa)	RV18CBS2 or RV18VRS10
RC25 50 Hz / 2 Pole	8 gpm at 152 psid Max (31 lpm at 1,050 kPa)	RV18CBS2 or RV18VRS14
RC25 60 Hz / 2 Pole	15 gpm at 203 psid Max (56 lpm at 1,400 kPa)	RV18CBS2 or RV18VRS14
RC40 50 Hz / 2 Pole	25 gpm at 152 psid Max (95 lpm at 1,050 kPa)	RV18CBS3 or RV18VRS19
RC40 60 Hz / 2 Pole	35 gpm at 203 psid Max (132 lpm at 1,400 kPa)	RV18CBS3 or RV18VRS19

SYSTEM PRE-STARTUP COMMISSIONING CHECKLIST

Date: _____ Pumpset Serial No. _____

Location: _____ Bypass Valve Model No / Serial No: _____

Installation Company: _____ Installer's Name: _____

Indicate Inspection Satisfactorily Completed with a in the appropriate box

- 1. Check for leak free installation at Pump and pipe connections.
- 2. Check for correct pipe/port orientation (check IN / OUT marking on Pump).
- 3. Ensure voltage is correct and that all relevant electrical components are adequate for the application.
- 4. Ensure motor overload relay setting does not exceed FLA of motor.

 **WARNING** Do not run Pump in reverse.
Severe internal damage to the Pump may result.

- 5. Direction of rotation –
This **MUST** be tested prior to Pump operation (check marking on Pump)

 **WARNING** Do not run Pump dry.
Severe internal damage to the Pump will result.

- 6. Valves should be in the following positions:
(see 'P&ID' schematic for locations)
- Pump Inlet Valve..... OPEN.....
- Valves to both Pressure Gauges..... OPEN.....
- Discharge Line Valve/s..... OPEN.....
- Vapor/Bypass Return Line Valve/s..... OPEN.....

 **WARNING** Do not start Pump against closed Discharge Valve or
with Inlet Valve closed or throttled

- 7. Ensure Storage Tank has adequate liquid and Pump is liquid filled before starting motor.....
- 8. Back off Bypass Valve Adjusting Screw fully i.e. Minimum differential pressure.....

Notes:

DIMENSIONS EBSRAY MODELS RC20 & RC25

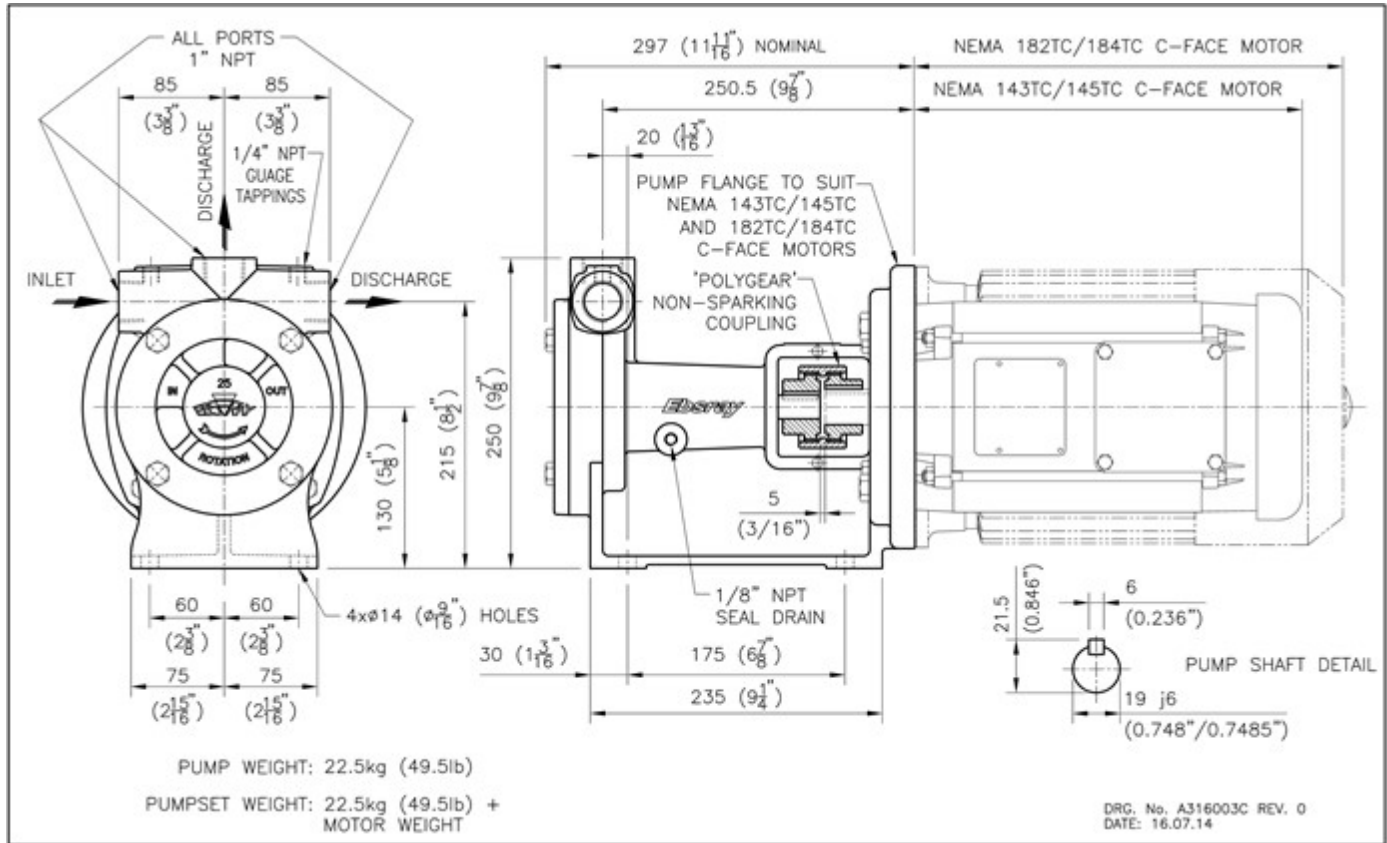

RC20 & RC25 with NEMA Motor Flange

DIMENSIONS EBSRAY MODELS RC40

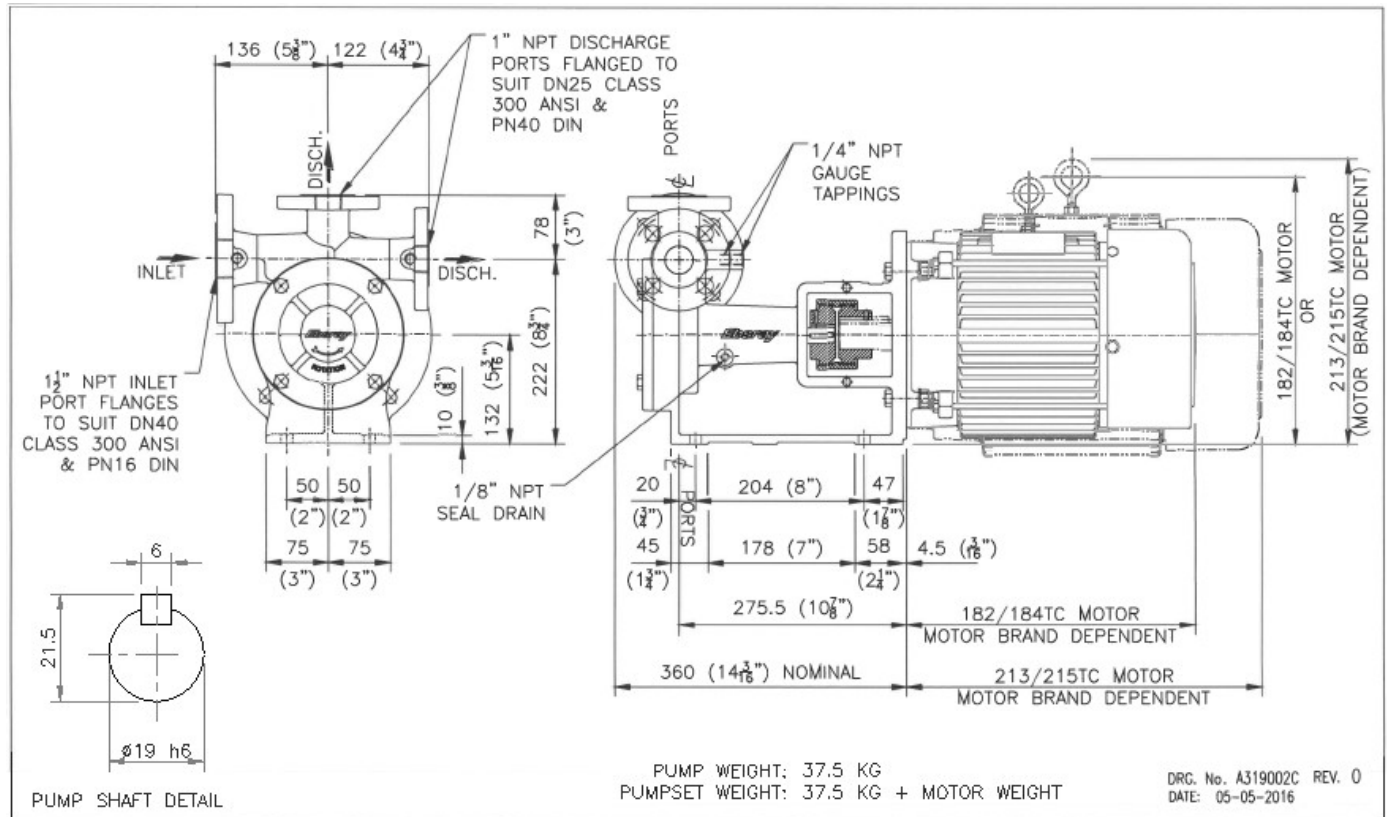



1809 Century Avenue, Grand Rapids, Michigan 49503-1530 U.S.A.
Telephone: (616) 241-1611 • Fax: (616) 241-3752
E-mail: blackmer@blackmer.com • Internet Address: www.blackmer.com

Visit www.blackmer.com for complete information on all Blackmer products