

BLACKMER SEAL-LESS PUMPS

INSTALLATION, OPERATION, AND MAINTENANCE INSTRUCTIONS

MODELS: SMVP15, SMVP30

963102

INSTRUCTIONS NO. 185/U

Section

100

Effective

January 1995

Replaces

April 1991

TABLE OF CONTENTS

Page

PUMP DATA	2
Technical Data.....	2
Initial Pump Start Up Information.....	2
INSTALLATION	2
Pre-Installation Cleaning.....	2
Location and Piping.....	2
Pump Mounting.....	2
Motor Installation.....	2
OPERATION	3
Pre-Start Up Check List.....	3
Start Up Procedures.....	3
Pump Rotation.....	3
Reverse Rotation.....	3
Flushing the Pump.....	4
Optional Pump Relief Valve.....	4
Relief Valve Setting and Adjustment.....	4
MAINTENANCE	4
Strainers.....	5
Lubrication.....	5
Vane Replacement.....	5
Pump Disassembly.....	5
Pump Assembly.....	6
TROUBLESHOOTING	8

SAFETY DATA**NOTICE:**

Blackmer Seal-Less pumps **MUST** only be installed in systems which have been designed by qualified engineering personnel. The system **MUST** conform to all applicable local and national regulations and safety standards.

This manual is intended to assist in the installation and operation of the Blackmer Seal-Less pumps, and **MUST** be kept with the pump.

Blackmer Seal-Less pump service shall be performed by qualified technicians **ONLY**. Service shall conform to all applicable local and national regulations and safety standards.

Thoroughly review this manual, all instructions and hazard warnings, **BEFORE** performing any work on the Blackmer Seal-Less pumps.

Maintain **ALL** system and Blackmer Seal-Less pump operation and hazard warning decals.

SAFETY DATA**This is a SAFETY ALERT SYMBOL.**

When you see this symbol on the product, or in the manual, look for one of the following signal words and be alert to the potential for personal injury, death or major property damage.

▲ DANGER

Warns of hazards that **WILL** cause serious personal injury, death or major property damage.

▲ WARNING

Warns of hazards that **CAN** cause serious personal injury, death or major property damage.

▲ CAUTION

Warns of hazards that **CAN** cause personal injury or property damage.

NOTICE:

Indicates special instructions which are very important and must be followed.

▲ WARNING

Explosive atmosphere can cause serious injury.

RARE EARTH MAGNETS MAY CREATE SPARKS THROUGH CONTACT IN HANDLING. NEVER HANDLE RARE EARTH MAGNETS IN EXPLOSIVE ATMOSPHERES WHERE SPARKING MAY IGNITE THAT ATMOSPHERE.

▲ WARNING

Strong Magnetic Field

STRONG MAGNETIC FIELDS CAN CAUSE SERIOUS PERSONAL INJURY OR DEATH TO INDIVIDUALS WITH MEDICAL IMPLANTS OR OTHER MAGNETIC FIELD SENSITIVE MEDICAL CONDITIONS.

▲ WARNING

Hazardous or toxic fluids can cause serious injury.

IF PUMPING HAZARDOUS OR TOXIC FLUIDS, SYSTEM MUST BE FLUSHED AND DECONTAMINATED, INSIDE AND OUT, PRIOR TO PERFORMING MAINTENANCE.

▲ WARNING

Hazardous voltage. Can shock, burn or cause death.

FAILURE TO DISCONNECT AND LOCKOUT ELECTRICAL POWER BEFORE ATTEMPTING MAINTENANCE CAN CAUSE SHOCK, BURNS OR DEATH.

▲ WARNING

Do not operate without guard in place.

OPERATION WITHOUT COUPLING GUARD CAN CAUSE SERIOUS PERSONAL INJURY, MAJOR PROPERTY DAMAGE, OR DEATH.

NOTE: Numbers in parentheses following individual parts indicate reference numbers on Blackmer Parts List No. 185/U3-185/U4

PUMP DATA

TECHNICAL DATA

	SMVP15, SMVP30
Maximum Pump Speed	1750 RPM
Maximum Operating Temperature	200°F (93°C)
Minimum Operating Temperature	-40°F (-40°C)
Maximum Viscosity	5,000 SSU (1,050 CP)*
Maximum Differential Pressure	125 psi (862 kPa)
Maximum Working Pressure (Inlet Pressure + Differential Pressure)	175 psi (1207 kPa)

*Conversion is based on a specific gravity of 1.0.

INITIAL PUMP START UP INFORMATION

Model No. _____
Serial No. _____
Date of Installation: _____
Pressure Gauge Reading: _____
Vacuum Gauge Reading: _____

INSTALLATION

NOTICE:

BLACKMER SEAL-LESS PUMPS MUST ONLY BE INSTALLED IN SYSTEMS DESIGNED BY QUALIFIED ENGINEERING PERSONNEL. SYSTEM DESIGN MUST CONFORM WITH ALL APPLICABLE REGULATIONS AND CODES AND PROVIDE WARNING OF ALL SYSTEM HAZARDS.

PRE-INSTALLATION CLEANING

Foreign matter entering the pump WILL cause extensive damage. The suction tank and piping MUST be cleaned and flushed prior to pump installation and operation.

LOCATION AND PIPING

An improperly designed piping system or improper unit installation WILL significantly reduce pump performance and life. Blackmer recommends the following piping system layout and unit installation.

1. To minimize intake losses, locate the pump as close as possible to the source of supply.
2. Intake piping and fittings MUST be at least as large in diameter as the pump intake connection.
3. Minimize the number of intake line fittings (valves, elbows, etc.) and piping turns or bends.
4. It is recommended an intake strainer be installed 5 - 10 pipe diameters from the pump intake. For viscosities less than 1000 SSU the strainer should have a net open area of at least four times the area of the intake pipe. For viscosities greater than 1000 SSU consult the strainer manufacturer instructions. Strainers must be cleaned regularly to avoid pump starvation.
5. Intake and discharge piping MUST be free of all leaks.
6. Piping should allow for expansion and contraction within 3 feet (0.9m) from the pump intake and discharge.
7. ALL piping and fittings MUST be properly supported to prevent any piping loads from being placed on the pump.
8. Install vacuum and pressure gauges in the 1/4" NPT ports provided in the pump cylinder to check pump at start up.

PUMP MOUNTING

It is recommended that the unit be permanently mounted by securing the magnet housing with four adequately sized anchor bolts to a level concrete floor. A solid foundation will reduce system noise and vibration, and will improve pump performance.

MOTOR INSTALLATION

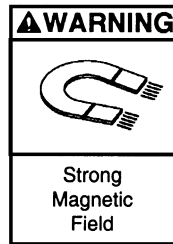

STRONG MAGNETIC FIELDS CAN CAUSE SERIOUS PERSONAL INJURY OR DEATH TO INDIVIDUALS WITH MEDICAL IMPLANTS OR OTHER MAGNETIC FIELD SENSITIVE MEDICAL CONDITIONS.



FAILURE TO USE CARE WHEN HANDLING MAGNETS CAN CAUSE PERSONAL INJURY.

NOTICE:

CLEAR WORK AREA OF ALL TOOLS AND MATERIALS AFFECTED BY MAGNETS. NON-MAGNETIC WORK SURFACE RECOMMENDED.

1. Install the magnet lockcollar (87) over the hub of the outer magnet (53). Slide the magnet ring over the motor shaft assembly to the Set & Clamp "A" dimension indicated in Figure 1 and Table 1. "A" = Motor bolt face to back of outer magnet.
2. Ensure that the shaft key (35) is in place, then tighten the two lockcollar capscrews to secure the outer magnet to the motor shaft.

INSTALLATION

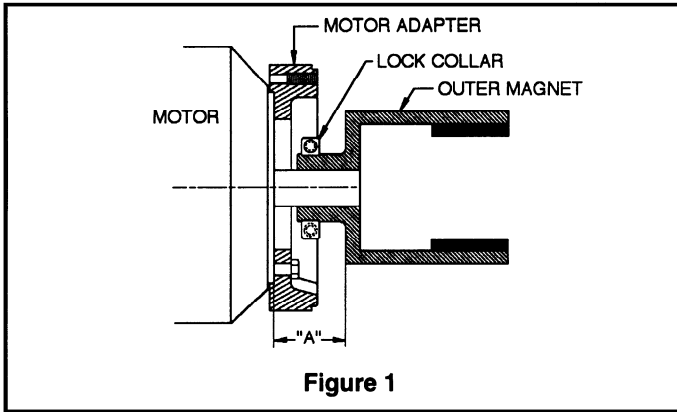

Figure 1

MOTOR FRAME	SET & CLAMP "A"
	SMVP15, SMVP30
143-145TC	2.01" (51.1 mm)
182-184TC	2.69" (68.3 mm)
213-215TC	2.79" (70.9 mm)

Table 1

- Slide the motor adapter (86) over the outer magnet and against the motor "C" face. Ensure the flange of the motor adapter is fully and squarely seated, and install the four

adapter/motor capscrews (56), torquing to 27 lbs ft (36.6 Nm).

NOTICE:

BE PREPARED FOR STRONG MAGNET ATTRACTION BETWEEN THE INNER AND OUTER MAGNETS, FORCIBLY PULLING THE MOTOR ASSEMBLY INWARD.

- With the magnet housing properly mounted to the foundation, CAREFULLY insert the outer magnet and motor assembly into the magnet housing (57).
- Ensure the magnet housing is fully and squarely seated, and install the four housing/adapter capscrews (54B), torquing to 27 lbs ft (36.6 Nm).



- ▲ Install, ground and wire to local and National Electrical Code requirements.
- ▲ Install an all-leg disconnect switch near the unit motor.
- ▲ Disconnect and lockout electrical power before installation or service.

- ▲ Electrical supply MUST match motor nameplate specifications.
- ▲ Motors equipped with thermal protection automatically disconnect motor electrical circuit when overload exists. Motor can start unexpectedly and without warning.

OPERATION



OPERATION WITHOUT COUPLING GUARD CAN CAUSE SERIOUS PERSONAL INJURY, MAJOR PROPERTY DAMAGE, OR DEATH.

PRE-START UP CHECK LIST

- Inspect piping and supports to ensure no piping loads are being placed on the pump.
- Inspect complete piping system to ensure all valves and fittings are in their start up or operation positions.
- Ensure all electrical connections are correct and tight.
- Jog the pump motor to ensure free and CLOCKWISE pump rotation, as viewed from the fan end of the motor.

START UP PROCEDURES

NOTICE:

CONSULT THE "TROUBLESHOOTING" SECTION OF THIS MANUAL IF DIFFICULTIES ARE EXPERIENCED DURING START UP.

- Start the motor. Priming should occur within one minute.
- Check the vacuum and pressure gauges installed on the pump to ensure the pump is operating within the acceptable parameters. Record the gauge readings in the "Initial Pump Start Up Information" section.

- If possible, check the flow rate to ensure the pump is operating within expected parameters.
- Inspect piping, fittings and associated system equipment for leaks, noise, vibration and overheating.

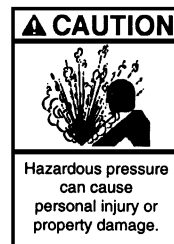

PUMP OPERATING AGAINST A CLOSED VALVE CAN CAUSE SYSTEM COMPONENT FAILURE, PERSONAL INJURY AND PROPERTY DAMAGE.

- If equipped, check the pressure relief setting of the pump relief valve by gradually closing a valve in the discharge line momentarily and noting the reading on the pressure gauge. This pressure reading should be 10 - 20 psi (69 - 138 kPa) higher than the maximum system operating pressure. **DO NOT run the pump for more than 15 seconds with the discharge valve completely closed.** If adjustments need to be made, refer to "Relief Valve Setting and Adjustment."

PUMP ROTATION

The SMVP15 and SMVP30 pump models are designed as RIGHT HAND pumps ONLY, with CLOCKWISE rotation. When viewing the pump from the drive end (motor end), the pump intake port must always be on the right, and the discharge port on the left.

OPERATION

REVERSE ROTATION

NOTICE:

MAGNETIC COUPLED PUMPS SHOULD BE OPERATED IN REVERSE ROTATION FOR NO MORE THAN 10 MINUTES, AND ONLY WHEN A SEPARATE PRESSURE RELIEF VALVE IS INSTALLED TO PROTECT THE PUMP FROM EXCESSIVE PRESSURE.

It may be desirable to operate the pump in reverse rotation for system maintenance. The pump will operate satisfactorily for a LIMITED period of time; however, depending on system conditions and the pump speed, the flow rate will be reduced.

FLUSHING THE PUMP

1. To flush the pump, run the pump with the discharge valve open and the intake valve closed. Bleed air into the pump through the intake gauge plug hole or through a larger auxiliary fitting in the intake piping. Pump air for 30 second intervals to clean out most of the pumpage.
2. Run a system compatible flushing fluid through the pump for one minute to clear out the remainder of the original pumpage.
3. To remove the flushing fluid, follow step 1 above. Any remaining fluid in the pump can be drained from the cylinder through the drain plugs (73A).

NOTICE:

PROPERLY DISPOSE OF ALL WASTE FLUIDS IN ACCORDANCE WITH THE APPROPRIATE STANDARDS AND REGULATIONS.

OPTIONAL PUMP RELIEF VALVE

The SMVP15 and SMVP30 pump models are offered with an optional pump relief valve assembly that bolts onto the pump cylinder. Blackmer STRONGLY RECOMMENDS the installation of the optional relief valve to protect the pump from excessive pressure, and a separate system pressure control valve to protect the system from excessive pressure.

NOTICE:

THE OPTIONAL PUMP RELIEF VALVE IS DESIGNED TO PROTECT THE PUMP FROM EXCESSIVE PRESSURE AND MUST NOT BE USED AS A SYSTEM PRESSURE CONTROL VALVE.

RELIEF VALVE SETTING AND ADJUSTMENT

The factory relief valve pressure setting is marked on a metal tag attached to the valve body. It is recommended the relief valve be set at least 10 - 20 psi (69-138 kPa) higher than the operating pressure or the system pressure control valve setting.

CAUTION

Hazardous Pressure

INCORRECT SETTINGS OF THE PRESSURE RELIEF VALVE CAN CAUSE PUMP COMPONENT FAILURE, PERSONAL INJURY AND PROPERTY DAMAGE.

WARNING



Hazardous or toxic fluids can cause serious injury.

RELIEF VALVE CAP IS EXPOSED TO PUMPAGE AND WILL CONTAIN SOME FLUID.

Relief Valve Adjustment Procedure:

1. To **INCREASE** the pressure setting, remove the relief valve cap (1) and gasket (88), and turn the adjusting screw (2) inward, or **CLOCKWISE**. Install a new R/V gasket (88), and re-attach the R/V cap.
2. To **DECREASE** the pressure setting, remove the relief valve cap (1) and gasket (88), and turn the adjusting screw (2) outward, or **COUNTERCLOCKWISE**. Install a new R/V gasket (88), and re-attach the R/V cap.

Refer to Blackmer Parts List 185/U3-185/U4 for relief valve spring pressure ranges.

MAINTENANCE

WARNING



Hazardous voltage. Can shock, burn or cause death.

FAILURE TO DISCONNECT AND LOCKOUT ELECTRICAL POWER BEFORE ATTEMPTING MAINTENANCE CAN CAUSE SHOCK, BURNS OR DEATH.

WARNING

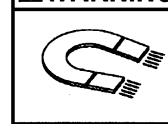

Strong Magnetic Field

STRONG MAGNETIC FIELDS CAN CAUSE SERIOUS PERSONAL INJURY OR DEATH TO INDIVIDUALS WITH MEDICAL IMPLANTS OR OTHER MAGNETIC FIELD SENSITIVE MEDICAL CONDITIONS.

WARNING



Hazardous or toxic fluids can cause serious injury.

IF PUMPING HAZARDOUS OR TOXIC FLUIDS, SYSTEM MUST BE FLUSHED AND DECONTAMINATED, INSIDE AND OUT, PRIOR TO PERFORMING MAINTENANCE.

WARNING



Explosive atmosphere can cause serious injury.

RARE EARTH MAGNETS MAY CREATE SPARKS THROUGH CONTACT IN HANDLING. NEVER HANDLE RARE EARTH MAGNETS IN EXPLOSIVE ATMOSPHERES WHERE SPARKING MAY IGNITE THAT ATMOSPHERE.

MAINTENANCE

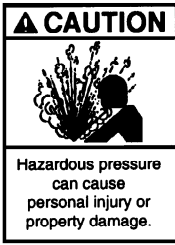

FAILURE TO RELIEVE SYSTEM PRESSURE PRIOR TO PERFORMING PUMP SERVICE OR MAINTENANCE CAN CAUSE PERSONAL INJURY OR PROPERTY DAMAGE.

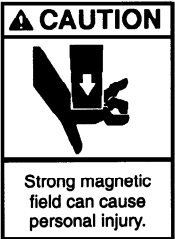

FAILURE TO USE CARE WHEN HANDLING MAGNETS CAN CAUSE PERSONAL INJURY.

NOTICE:

MAINTENANCE SHALL BE PERFORMED BY QUALIFIED TECHNICIANS ONLY, FOLLOWING THE APPROPRIATE PROCEDURES AND WARNINGS AS PRESENTED IN THIS MANUAL.

NOTICE:

PROPERLY DISPOSE OF ALL WASTE FLUIDS ACCORDING TO STATE AND LOCAL REGULATIONS.

NOTICE:

CLEAR THE WORK AREA OF ALL TOOLS AND MATERIALS AFFECTED BY MAGNETS. NON-MAGNETIC WORK SURFACE RECOMMENDED.

STRAINERS

Adequately sized system strainers are recommended. Strainers MUST be kept clean to ensure adequate fluid flow to the pump. Failure to do so can cause pump cavitation and system damage.

LUBRICATION

Pump sleeve bearings are lubricated by the pumpage. No other lubrication is required. For motor lubrication, refer to the manufacturer's instructions.

VANE REPLACEMENT

NOTICE:

FOLLOW ALL HAZARD WARNINGS AND INSTRUCTIONS PROVIDED IN THE "MAINTENANCE" SECTION OF THIS MANUAL.

1. Drain the pump and system, as required. Drain plugs (73A) are located at the base of the cylinder.
2. For replacement of the vanes ONLY, remove the outboard head, following steps 10 and 11 in the "Pump Disassembly" section of this manual.
3. Turn the shaft by hand until a vane (14) comes to the top (12 o'clock) position of the rotor. Remove the vane.
4. Install a new vane, ensuring that the rounded edge is UP (facing outward) and that the relief grooves are facing TOWARDS the direction of rotation. See Figure 3.
5. Repeat steps 2 and 3 until all vanes have been replaced.
6. To reassemble, follow steps 2 through 7 in the "Pump Assembly" section of this manual.

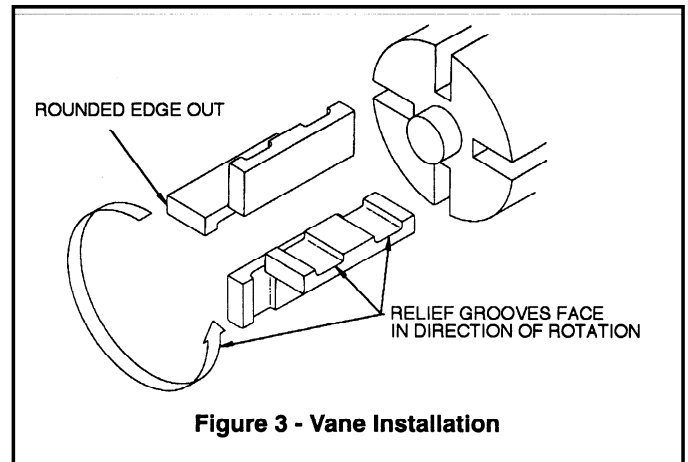

PUMP DISASSEMBLY

NOTICE:

FOLLOW ALL HAZARD WARNINGS AND INSTRUCTIONS PROVIDED IN THE "MAINTENANCE" SECTION OF THIS MANUAL.

NOTICE:

THE MAGNET HOUSING SHOULD REMAIN MOUNTED TO ITS BASE DURING PUMP DISASSEMBLY. IF REMOVED, THE MAGNET HOUSING MUST BE SECURED BEFORE PUMP DISASSEMBLY.

1. Drain the pump and system, as required. Drain plugs (73A) are located at the base of the cylinder.
2. Disconnect the piping from the pump intake and discharge connections.
3. Remove the four magnet housing/head capscrews (54A)

NOTICE:

BE PREPARED FOR STRONG MAGNETIC ATTRACTION BETWEEN THE INNER AND OUTER MAGNETS, FORCIBLY PULLING THE PUMP ASSEMBLY INWARD.

4. While facing the outboard end of the pump, grasp the pump cylinder (12) with two hands and firmly pull the pump assembly from the magnet housing.
5. Remove the containment can (50) from the inboard head, using a slight pry, if necessary. DO NOT damage the containment can or pump head. Remove and discard the containment can O-ring (51).



FAILURE TO USE CARE WHEN HANDLING MAGNETS CAN CAUSE PERSONAL INJURY.

6. With properly sized snap ring pliers, remove the snap ring (83) from the shaft end. Pull the inner magnet (52) from the shaft. Remove the shaft key (35).
7. Remove the four socket head capscrews (21) from the inboard head and bearing assembly (20). Carefully slide the inboard head assembly off the shaft. A pry may be necessary to separate the head and cylinder. DO NOT damage head, cylinder or shaft.

MAINTENANCE

8. Remove the disc (71) and head seal ring (72) from the cylinder. Discard the head seal ring.
9. Carefully pull the rotor and shaft assembly (13) from the cylinder while preventing the vanes (14) and push rods (77) from falling out of the rotor. Set the rotor and shaft assembly aside for future vane replacement and reassembly.
10. Remove the four bearing cover capscrews (28) and the bearing cover (27). Remove and discard the bearing cover seal ring (26).
11. Remove the four outboard head capscrews (21A) and the outboard head and bearing assembly (23). Use care not to let the disc fall and become damaged.

Magnet Housing Disassembly



FAILURE TO USE CARE WHEN HANDLING MAGNETS CAN CAUSE PERSONAL INJURY.

1. Remove the four housing/adaptor capscrews (54B), and pull the motor, motor adapter (86) and outer magnet (53) from the magnet housing (57).
2. Loosen the two magnet lockcollar (87) capscrews, releasing the outer magnet assembly. It may be necessary to remove the motor adapter (86) to reach the lockcollar. Slide the outer magnet assembly from the motor shaft.
3. Pump and magnet housing disassembly is complete.

PUMP ASSEMBLY

NOTICE:

FOLLOW ALL HAZARD WARNINGS AND INSTRUCTIONS PROVIDED IN THE "MAINTENANCE" SECTION OF THIS MANUAL.



CONTAINMENT CAN FAILURE WILL PERMIT FLUID LEAKAGE AND CAN CAUSE SERIOUS INJURY.

Before reassembling the pump, all parts should be thoroughly cleaned and inspected for wear, damage, and replaced as necessary. Remove any burrs from the rotor and mating cylinder.

NOTICE:

THE CONTAINMENT CAN (50) MUST BE REPLACED IF ANY CORROSION, CRACKING, WEAR OR OTHER DAMAGE IS PRESENT.

1. Begin assembly on the **outboard** side of the pump first, by laying the pump cylinder (12) on a flat surface with the intake port to the LEFT.
2. Install the disc (71) on the outboard end of the cylinder with

the disc holes positioned as shown in Figure 4. Use the dowel locator pin hole to locate the disc.

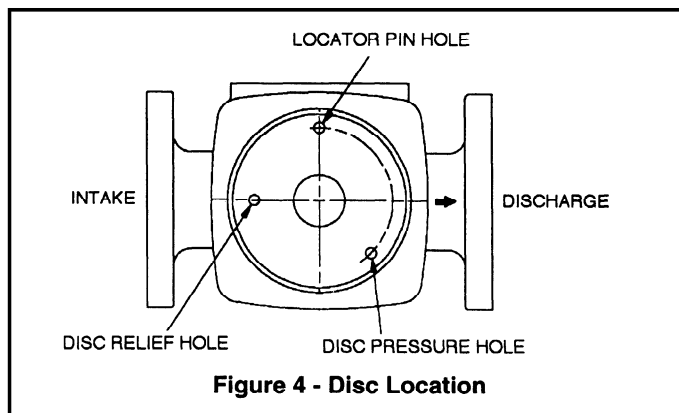

Figure 4 - Disc Location

3. Install a new head seal ring (72) in the groove provided between the disc and the cylinder.
4. Inspect both sleeve bearings (24) for damage or wear. If damaged, bearings **MUST** be replaced. If the inside diameter of the bearing measures 1.074" (27.28mm) or greater at any point around the entire circumference, bearings **MUST** be replaced. To replace bearings:
 - a. Using an appropriately sized arbor press, remove the old bearing from the head.
 - b. To aid installation and prevent damage, heat the head in an oven to 200°F (93°C).
 - c. Coat the new bearing with a quality grade of bearing grease, and place it on the inside face of the head with the notched end UP. **Align the notch in the bearing with the groove in the head.**
 - d. Using an arbor press, **CAREFULLY** press the bearing into the head until it is flush with the inside face of the head. Ensure that the bearing does not become misaligned during the pressing activity.
5. Install the outboard head and bearing assembly (23) on the pump cylinder with the V-notch down, towards the bottom of the cylinder. Use the head dowel pins for proper alignment.
6. Lubricate the four outboard head capscrews (21A) with a quality grade of anti-seize compound and install, torquing to 15 lbs ft (20.3 Nm).
7. Install a new bearing cover seal ring (26) in the groove in the outboard head. Place the bearing cover (27) on the head. Lubricate the bearing cover capscrews (28) with a quality grade of anti-seize compound, and install, torquing to 11 lbs ft (15 Nm).
8. Turn the pump cylinder over so that it rests on the just installed outboard head and bearing cover.
9. Remove the four vanes (14) and two push rods (77) from the rotor assembly. Inspect for wear and damage, and replace as follows:
 - a. The push rods **MUST** be installed before installing the rotor and shaft (13) into the pump cylinder. To do so, hold the rotor and shaft vertical, with the non-driven (shorter end) down. Slide the push rods into the push

MAINTENANCE

rod holes of the rotor, then insert the rotor and shaft into the open end of the pump cylinder.

- b. Insert new vanes into the rotor slots with the rounded edges outward, and the vane relief grooves facing TOWARDS the direction of rotation. Refer back to Figure 3. If necessary, move the push rods with a small screwdriver to install the vanes.

10. Install the inboard disc (71), head seal ring (72), and sleeve (24) bearing as instructed in steps 2 through 4 above.
11. Install the inboard head and bearing assembly (20) on the pump cylinder with the V-notch down, towards the bottom of the cylinder. Use the head dowel pins for proper alignment.
12. Lubricate the four inboard head capscrews (21) with a quality grade of anti-seize compound, and install, torquing to 15 lbs ft (20.3 Nm).

Magnet Housing Assembly

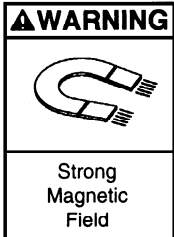

STRONG MAGNETIC FIELDS CAN CAUSE SERIOUS PERSONAL INJURY OR DEATH TO INDIVIDUALS WITH MEDICAL IMPLANTS OR OTHER MAGNETIC FIELD SENSITIVE MEDICAL CONDITIONS.



FAILURE TO USE CARE WHEN HANDLING MAGNETS CAN CAUSE PERSONAL INJURY.

1. Install the shaft key (35) on the inboard shaft end.
2. Align the inner magnet (52) with the key, and slide the magnet over the shaft with the pump end of the magnet towards the inboard head.
3. Fully and squarely install the snap ring (83) into the groove in the end of the shaft.

4. Check to ensure the pump shaft rotates freely when turned by hand.
5. Install a new containment can O-ring (51) into the groove provided on the hub of the inboard head (20). Slide the containment can (50) over the magnet and push it firmly against the inboard head.
6. Slide the outer magnet (53) and the loose magnet lockcollar (87) onto the motor shaft, with the lockcollar end towards the motor. Refer to Figure 1 and Table 1 in the "Motor Installation" section of this manual for the proper "Set & Clamp "A" dimension of the lockcollar. Securely tighten the two magnet lockcollar capscrews.
7. Slide the motor adapter (86) over the outer magnet and against the motor "C" face. Ensure the flange of the motor adapter is fully and squarely seated, and install the four adapter/motor capscrews (56), torquing to 27 lbs ft (36.6 Nm).
8. Slide the motor, motor adapter and outer magnet into the mounted magnet housing.
9. Install the four housing/adaptor capscrews (54B) torquing to 27 lbs ft (36.6 Nm).

NOTICE:

BE PREPARED FOR STRONG MAGNET ATTRACTION BETWEEN THE INNER AND OUTER MAGNETS, FORCIBLY PULLING THE PUMP ASSEMBLY INWARD.

10. CAREFULLY slide the pump assembly into the magnet housing.
11. Apply anti-seize compound to the four housing/head capscrews (54A), and install, torquing to 27 lbs ft (36.6 Nm).
12. Reinstall the piping to the pump intake and discharge connections.
13. Reassembly is complete.

NOTICE:

FOLLOW ALL STEPS IN THE "OPERATION" SECTION OF THIS MANUAL FOR START UP PROCEDURES.

TROUBLESHOOTING



FAILURE TO DISCONNECT AND LOCKOUT ELECTRICAL POWER BEFORE ATTEMPTING MAINTENANCE CAN CAUSE SHOCK, BURNS OR DEATH.

NOTICE:
MAINTENANCE SHALL BE PERFORMED BY QUALIFIED TECHNICIANS ONLY, FOLLOWING THE APPROPRIATE PROCEDURES AND WARNINGS AS PRESENTED IN THIS MANUAL.

PROBLEM	CAUSE
<p>Pump Not Priming See causes 1 through 7</p> <p>Reduced Capacity See causes 1, 2, 3, 6 through 10</p> <p>Noisy See causes 1, 6, 7, 8, 9, 11 through 14</p> <p>Damaged Vanes See causes 8, 11, 16 through 21</p> <p>Broken Shaft See causes 7, 11, 13, 16, 17 & 20</p> <p>Motor Overload See causes 9, 13, 17, 22 & 23</p>	<ol style="list-style-type: none"> 1. Suction/discharge valve incorrectly set. 2. Leaks in suction piping. 3. Incorrect rotation. 4. Broken shaft. 5. Pump vapor locked. 6. Incorrect pump speed. 7. Vanes damaged, worn or incorrectly installed. 8. Cavitation. 9. Damaged or worn pump or system components. 10. Excessive piping/system friction losses. 11. Relief valve incorrectly set, worn or damaged. 12. Operating against a closed discharge. 13. Shaft bent or misaligned. 14. Worn or damaged bearings. 15. Piping inadequately anchored. 16. Foreign objects entering the pump. 17. Viscosity too high. 18. Excessive heat. 19. Worn or damaged push rods. 20. Hydraulic hammer - pressure spikes. 21. Incompatible fluid(s). 22. Inadequate horsepower. 23. Incorrect voltage, wiring, phase loss.

blackmer

A **DOVER** RESOURCES COMPANY

1809 Century Avenue, Grand Rapids, Michigan 49503, U.S.A
(616) 241-1611 • Fax: (616) 241-3752 • www.blackmer.com