



Page Number	011-035
Effective	Dec 2023
Replaces	Aug 2021
Section	011

r150813

Piping systems should be designed and installed by qualified personnel only. Improperly installed systems can result in excessive strain on the pump, resulting in reduced seal and bearing life.

Piping Strain

The suction and discharge pipe flanges must be aligned concentric and parallel to the pump flanges. **The piping must be supported independently near the pump, and all flanges must match so that no strain will be transmitted to the pump** after the nuts and bolts have been securely fastened. When tightening the nuts and bolts, always tighten bolts 180° opposite from each other in an alternating pattern to achieve even gasket compression. Do not draw the piping into the pump by force.

The piping system should be designed with sufficient inherent flexibility to withstand thermal expansion without creating excessive forces at the flanges. The piping must also be arranged and supported so that no excessive stress can be transmitted to the pump, either due to the weight of the pipe and fluid, or to its expansion and contraction.

Excessive strain on a pump may be the result of:

1. Thermal expansion and contraction of the piping. This indicates improper piping design. Expansion joints or loops may have to be installed.
2. Improper pipe support. Frequent problems arise from indiscriminate use of rod hangers (instead of spring hangers), anchors or restraints used during the pipe installation.
3. Misalignment of the pipe flanges to the pump suction and discharge flanges.

The table on the next page shows the maximum Forces and Moments allowed on Blackmer pump nozzles.

X – Horizontal (parallel to shaft)
 Y – Vertical
 Z – Horizontal (perpendicular to shaft)

Coordinates per API® 676

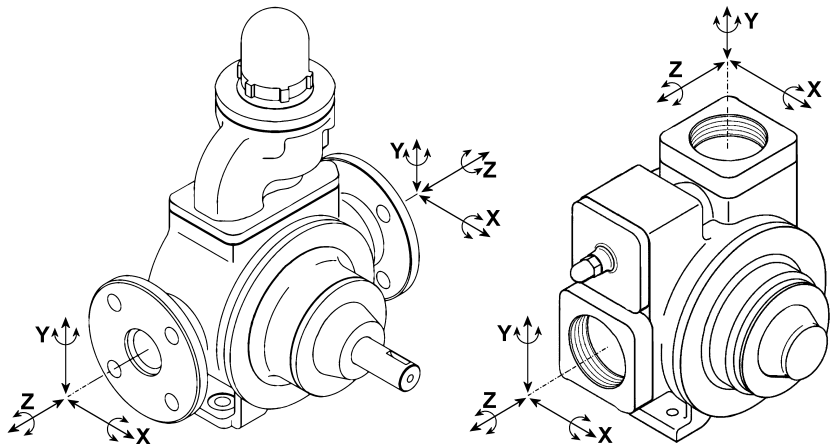

Pump Models	Forces (lb / kg)			Moments (ft-lb / kg-m)		
	F _X	F _Y	F _Z	M _X	M _Y	M _Z
0.75, 1", 1.25 & 1.5" Models *						
LGL1.25, XL1.25, SGL1.25, CRL1.25, X1, LGB1, LGF1	50 / 23	75 / 34	60 / 27	50 / 7	75 / 10	75 / 10
LGL1.5, XL1.5, SGL1.5, CRL1.5	50 / 23	75 / 34	60 / 27	50 / 7	75 / 10	75 / 10
LGL154, LGL156, LGL158	150 / 68	150 / 68	150 / 68	250 / 35	250 / 35	250 / 35
SNP1.25, SNP1.5, SMVP15, SMVP30	45 / 20	45 / 20	45 / 20	75 / 10	75 / 10	75 / 10
2", 2.5" Models						
LGL2, XL2, XLW2, SGL2, CRL2	75 / 34	150 / 68	100 / 45	175 / 24	200 / 28	150 / 21
NP(H)2, X(H)2, GNX(H)2, TXD2, TXSD2	75 / 34	150 / 68	100 / 45	175 / 24	200 / 28	150 / 21
SNP2, SMVP50, SMVP100	75 / 34	75 / 34	75 / 34	125 / 17	125 / 17	125 / 17
NP(H)2.5, X(H)2.5, GNX(H)2.5, TXD2.5, TXSD2.5, TXV2.5	75 / 34	150 / 68	100 / 45	175 / 24	200 / 28	150 / 21
SNP2.5	185 / 84	185 / 84	185 / 84	312 / 43	250 / 35	312 / 43
3", 4" Models						
TLGLF3***, TLGLF3HD***, TLGLF4***	75/34	150/68	100/45	175/24	200/28	150/21
LGL3, XL3, XLW3, SGL3, CRL3	110 / 50	200 / 91	140 / 63	240 / 33	300 / 41	200 / 28
NP(H)3, X(H)3, GNX(H)3, TXD3, TXSD3, TXV3, MI3	110 / 50	200 / 91	140 / 63	240 / 33	300 / 41	200 / 28
SNP3, STX3, MS3	225 / 102	225 / 102	225 / 102	350 / 48	275 / 38	350 / 48
SMVP200	225 / 102	225 / 102	225 / 102	350 / 48	350 / 48	350 / 48
LGL4, XL4, XLW4, CRL4, SGLD4	140 / 63	250 / 113	180 / 82	400 / 55	350 / 48	350 / 48
NP(H)4, X(H)4, GNX(H)4, TX4, MI4	160 / 73	300 / 136	200 / 91	420 / 58	400 / 55	390 / 54
MLX4, MLN4	300 / 136	375 / 170	225 / 102	450 / 62	375 / 52	412 / 57
MS4**	300 / 136	300 / 136	300 / 136	500 / 69	500 / 69	500 / 69
6", 8" & 10" Models						
HXL6	600 / 272	750 / 340	450 / 204	900 / 124	750 / 104	825 / 114
HXL8, HXLJ8	600 / 272	750 / 340	450 / 204	900 / 124	1,050 / 145	825 / 114
HXL10	750 / 340	750 / 340	750 / 340	1,250 / 173	1,250 / 173	1,250 / 173

* All 0.75 – 1.5" pump data is for **foot-mounted** pumps. Pumps fitted to a C-face motor **must** have piping fully supported.

Consult factory for unlisted models.

** Note: MS4 pump is designed to minimum nozzle load requirement as specified by API® 676, 3rd Edition

***It is assumed that loads and moments are only applied to the discharge flange

