

BLACKMER PARTS LIST

PUMP MODELS: XF1C, XB1C, XF1PC, XB1PC

and Discontinued Models XF1(P)B, XB1(P)B, XF1(P)A, XB1(P)A

Keep with Instructions 101-A00 for Installation, Operation and Maintenance

961221

Page 1 of 2

PARTS LIST

101-A01

Section
Effective
Replaces

101
Dec 2021
Jun 2014

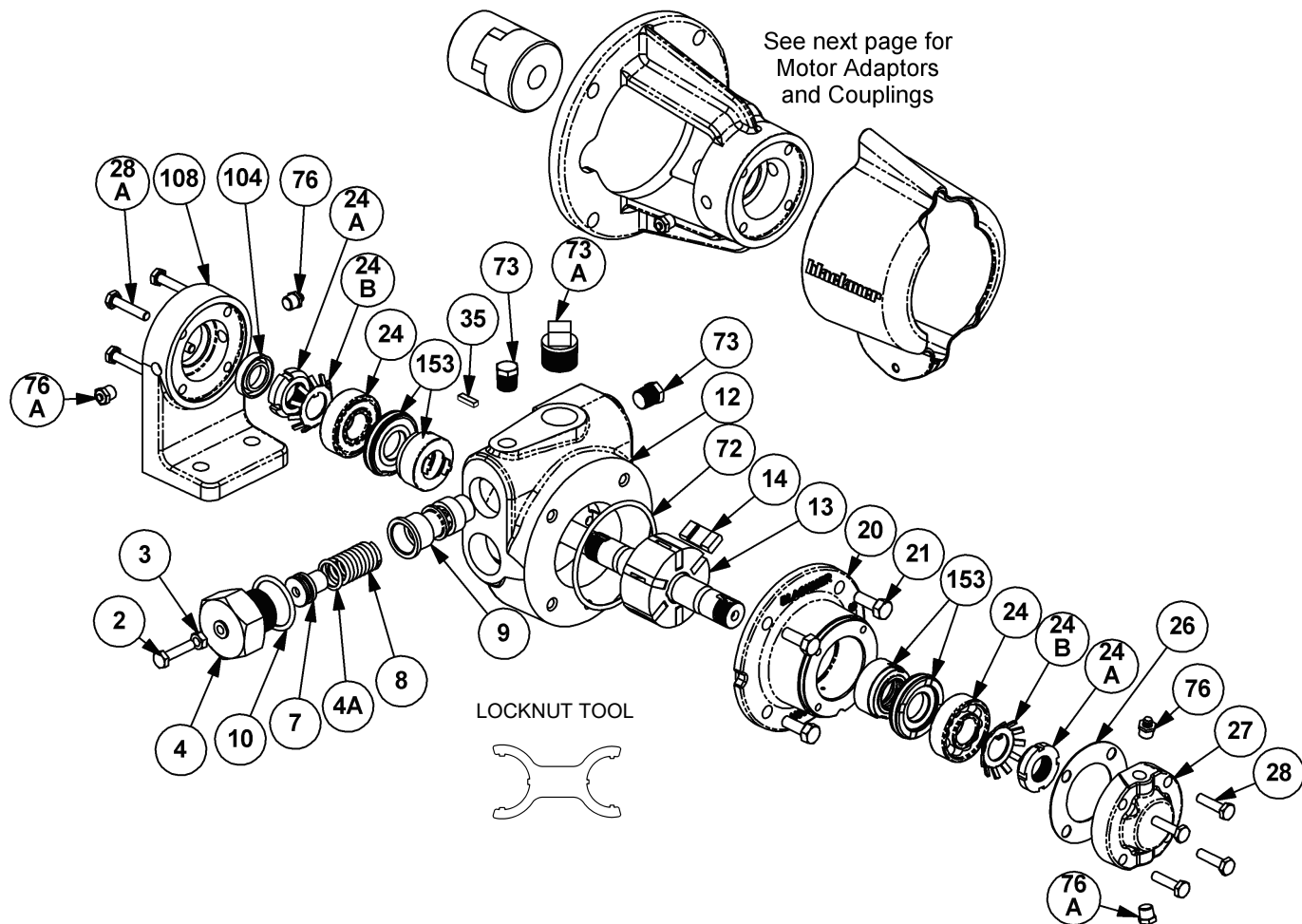

Ref. No.	Description	Parts per Pump	Part No.	Ref. No.	Description	Parts per Pump	Part No.
2	Adjusting Screw – Relief Valve (R/V)	1	432901	24A	Locknut – Bearing	2	903531
3	Locknut – Adjusting Screw	1	922811	24B	Lockwasher – Bearing	2	¹ 903532
4	Cover – R/V	1	412901	26**	Gasket – Bearing Cover	1	¹ 383075
4A	O-Ring – Spring Guide (FKM)	1	702029	27**	Bearing Cover	1	043071
7	Spring Guide – R/V	1	422901	28**	Capscrews – Bearing Cover	8	920080
8	Spring – R/V (66 - 125 psi) (Std.)	1	472905	28A**	Bracket Mounting Screws	4	920090
	Spring – R/V (35 - 65 psi)		472903	35	Key – Shaft, Square	1	^{1,2} 909152
9	Valve – R/V (Std.)	1	452901	72	O-Ring – Head (FKM) (Std.)	1	¹ 711930
10	O-Ring – R/V Cover (FKM)	1	701969	73	Gage Plug (1/4")	2	908198
12**	Cylinder – XF1, XB1	1	022914	73A**	Gage Plug (3/4")	1	908225
	Cylinder – XF1P, XB1P		022915	76	Grease Fitting	2	317815
13	Rotor & Shaft Assembly, Six Vane (Includes Ref. Nos. 24A & 24B)	1	³ 262910	76A	Grease Relief Fitting	2	701992
14	Vane – Duravane (Std.)	4, 6	^{1,4} 092913	104	Grease Seal	1	¹ 331934
20**	Head	1	032905	108**	Mounting Foot – XB1B/C & XB1PB/C	1	832913
21	Capscrews – Head	4	920178		Tool - Locknut		903090
24	Ball Bearing	2	¹ 903405		Kit – Maintenance (4-Vane)		898960
					Kit – Maintenance (6-Vane)		898995

¹ Included in Maintenance Kit ² Maintenance Kit also includes Woodruff Key 909126 used previously

³ Discontinued 'B' and 'A' models shipped with a 4-vane rotor. The 6-vane rotor is interchangeable if slotted vanes (pn 092913) are used.

⁴ The current slotted vanes (pn 092913) may be used in either the 6-vane or 4-vane rotors. The discontinued solid vanes may be used in the 4-vane rotors ONLY. Always install the vanes with the slot facing the direction of rotation.

** To fit the XF1(P)A, XB1(P)A use: Ref. No. 12-022902/022911 respectively, Ref. No. 20-032902, Ref. No. 26-382901, Ref. No. 27-042901, Ref. No. 28-920203, Ref. No. 28A & B-920230, Ref. No. 73A-908198 and Ref. No. 108-832901/832905 respectively.

MECHANICAL SEAL

Ref. No.	Part Name	Parts Per Pump	Part No.
153	Mechanical Seal Assembly	2	1 332921
	Hardened Steel Stationary Seat, Carbon Rotating Seal Face, FKM O-Rings (SVCV) (std)		
	Hardened Steel Stationary Seat with FKM O-Ring, Carbon Rotating Seal Face with PTFE Seal Ring (SVCT)		332924
153A	Jacket Assembly	2	*
153B	Stationary Seat – Hardened Steel	2	*
153D	O-Ring – Stationary (FKM)	2	711908
153F	Rotating Seal Face	2	*
153G	O-Ring – Rotating (FKM)	2	711942
	Seal Ring – Rotating (PTFE)		*
153N	Seal Backup Ring (Steel)	2	332906

¹ Included in Maintenance Kit

* Not available as a separate part.

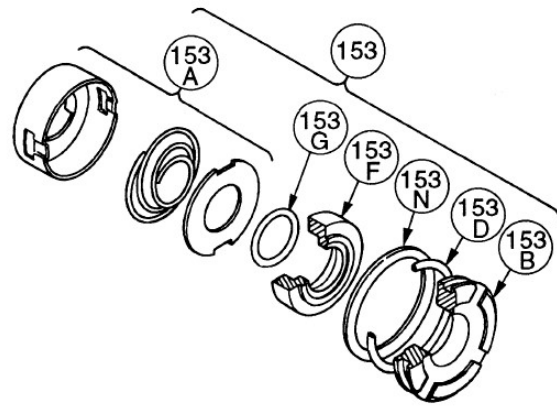

NEMA C-Faced Motor Adaptors – XF Models

Ref. No.	Part Name	Parts Per Pump	Part No.
28B**	Bracket Mounting Screws	4	920101
28C	Guard Screw	1	920026
34	Coupling Half – Pump	1	906150
	Coupling Half – Motor 56C		906151
	Coupling Half – Motor 143/145TC, 184C		906147
	Coupling Spider		906155
108	Motor Adaptor – Unfooted	1	832912
	Motor Adaptor- Footed		833000
108A	Capscrew – Bracket	4	920331
186	Guard	1	804120

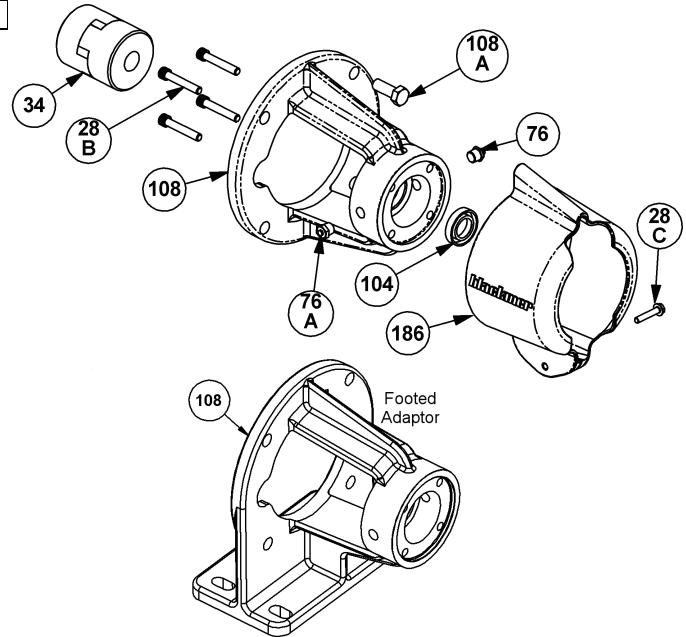

IEC Motor Adaptors – XF Models

Ref. No.	Description	Parts per Pump	Part No.
28B	Bracket Mounting Screws	4	920101
28C	Guard Screw	2	920026
34	Coupling Half – Pump	1	906183
	Coupling Spider		906176
	Coupling Half – Motor (IEC 90)		906186
76	Grease Fitting	1	317815
76A	Grease Relief Fitting	1	701992
76B	Extension Coupling	2	701905
104	Grease Seal	1	331934
108A	Capscrew – Bracket to Motor	4	920043
108C	Motor Adaptor (IEC90 B14A) Includes Ref. Nos. 76, 76A & 76B	1	832920
108D	Washer	4	792094
186C	Guard Half	2	804196

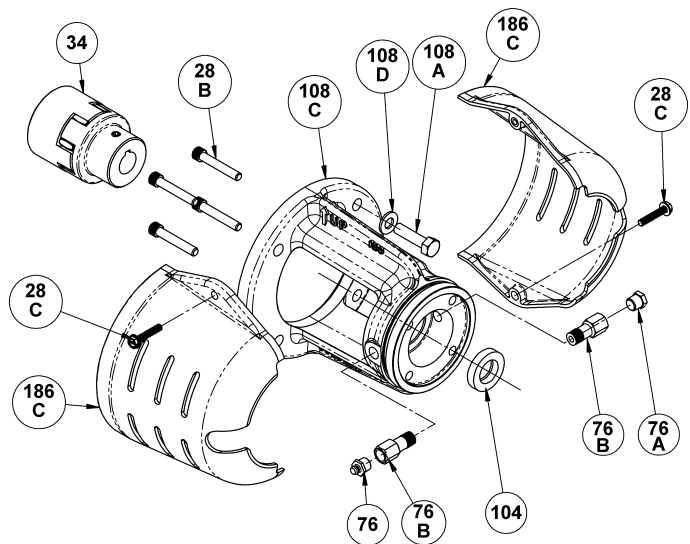

1809 Century Avenue, Grand Rapids, Michigan 49503-1530, U.S.A.
 Telephone: (616) 241-1611 / Fax: (616) 241-3752
 E-Mail: blackmer@blackmer.com / Internet: www.blackmer.com

Parts List 101-A01
 Page 2 of 2