

BLACKMER PARTS LIST

PUMP MODEL: GNX(H)3A

961843
Page 1 of 2

PARTS LIST
101-C03

Keep with Instructions 101-C00 for Installation, Operation and Maintenance

Section 101
Effective May 2022
Replaces Mar 2022

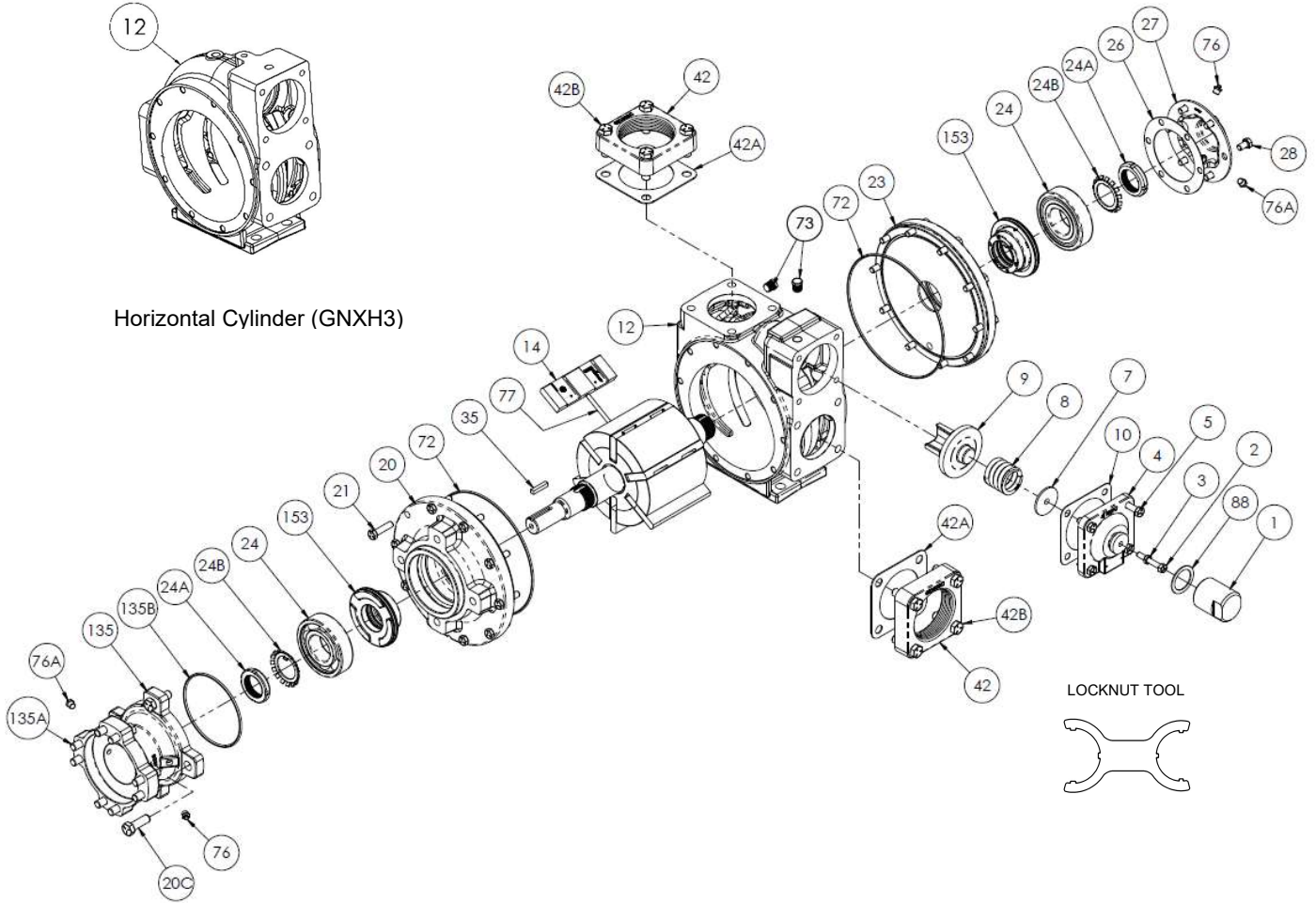

Ref. No.	Description	Parts per Pump	Part No.	Ref. No.	Description	Parts per Pump	Part No.
1	Cap - Relief Valve (R/V)	1	413957	24A	Locknut – Bearing	2	903523
2	Adjusting Screw - R/V	1	431808	24B	Lockwasher – Bearing	2	¹ 903524
3	Locknut – Adjusting Screw	1	922923	26	Gasket - Bearing Cover	1	¹ 385125
4	Cover - R/V	1	411807	27	Bearing Cover – Outboard	1	041817
5	Capscrew - R/V Cover	4	920331	28	Capscrews - Bearing Cover	6	920285
7	Spring Guide - R/V	1	421805	35	Key – Shaft, Square	1	¹ 909209
8	Spring - R/V (36-50 psi)	1	471805	42	Flange - 3" NPT (Std.) ²	2	651803
	Spring - R/V (51-110 psi)		471806	42A	Gasket - NPT Flange (Std.)	2	¹ 381816
9	Valve - R/V (Std.)	1	451807	42B	Capscrews - NPT Flange (Std.)	8	920532
	Valve - R/V (Nickel Plated)		451808	72	O-Ring - Head (FKM) (Std.)	2	¹ 711938
10	Gasket - R/V Cover	1	¹ 531803		O-Ring - Head (PTFE)		702082
12	Cylinder (90° Ported)	1	021805		O-Ring - Head (Buna-N)		701944
	Cylinder (Horizontally Ported)		021835	73	Gage Plug	2	908198
13	Rotor & Shaft (Includes Ref. Nos. 24A & 24B)	1	261859	76	Grease Fitting	2	317815
14	Vane - Duravane (Std.)	6	¹ 091819	76A	Grease Relief Fitting	2	701992
	Vane - EC Cast Iron		091821	77	Push Rod	3	¹ 121807
	Vane - EC Laminate		091829	88	Gasket - R/V Cap	1	¹ 533908
20	Head - Inboard	1	031825	135	Pump Adapter	1	833994
20C	Capscrew – Adapter	4	920510	135A	Capscrew – Adapter (Metric)	8	924042
21	Capscrews - Head	20	920369	135B	O-Ring – Adapter (FKM)	1	711966
23	Head – Outboard	1	031815		Tool - Locknut		903091
24	Ball Bearing	2	¹ 903172		Kit - Maintenance		898958

MECHANICAL SEALS

Ref. No.	Part Name	Parts Per Pump	Part No.
153	Mechanical Seal Complete - (Std.) Cast Iron Stationary Seat, Carbon Seal Face, FKM O-Rings. (IVCV)	2	¹ 331883
	Mechanical Seal Complete - Cast Iron Stationary Seat, PTFE O-Ring, Carbon Seal Face w/ PTFE Seal Ring. (IACT)		331873
	Mechanical Seal Complete - Stainless Steel Stationary Seat, PTFE O-Ring, Carbon Seal Face w/ PTFE Seal Ring. (WACT)		331899
	Mechanical Seal Complete - Cast Iron Stationary Seat, Carbon Seal Face, Buna-N O-Rings. (INCN)		331880
153D	O-Ring - Stationary (FKM)	2	711931
	O-Ring - Stationary (PTFE)		702080
	O-Ring - Stationary (Buna-N)		701936
153L	O-Ring - Rotating (FKM)	2	701962
	Seal Ring - Rotating (PTFE)		**
	O-Ring - Rotating (Buna-N)		711912

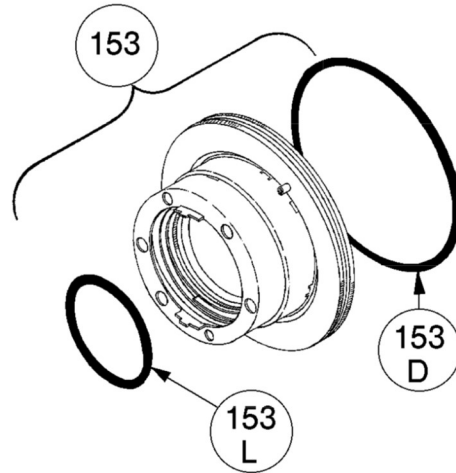

¹ Included in Maintenance Kit

**PTFE Rotating Seal Ring is not available as a separate part.

FLANGE OPTIONS

Ref. No.	Part Name	Parts Per Pump	Part No.
42	Flange - 3" Weld	2	655102
	Flange - 3" ANSI		651817
42B	Capscrews - Weld / ANSI Flange	8	920510
42C	O-Ring - Weld/ANSI Flg. (FKM)	2	701968
	O-Ring - Weld/ANSI Flg. (PTFE)		702101
	O-Ring - Weld/ANSI Flg (Buna-N)		701937

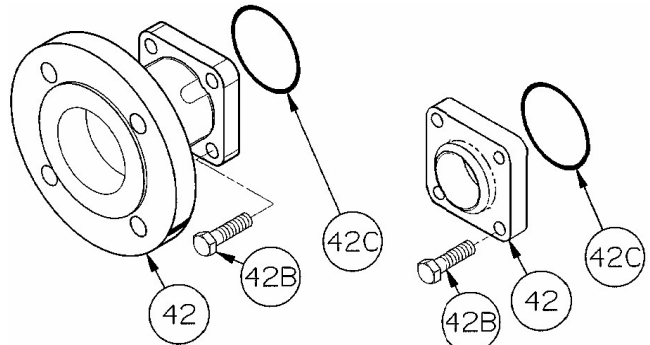

ANSI FLANGE

WELD FLANGE

