

Blackmer Centrifugal® PARTS

Frame M

Keep with Instructions 1301-C00 for Installation, Operation and Maintenance

PN: 967108	PARTS LIST
	1301-C04
Section	1301
Effective	Jan 2022
Replaces	Apr 2018

	Page
X-Section Drawing	2
Casings & Impellers (Ref #1 & 2)	3
Shafts / Rotating Elements (ref #6)	3
Back Covers (Ref #11)	3
Other Parts (Ref #11 - 897)	4 - 5

Recommended Spare parts (Ref # is shaded)

Ref #	Description
2	Impeller
6-RE	Rotating Element
72	Frame Adapter O-ring
73A	Casing Gasket
80	Mechanical Seal
89B	Lab Seal Rotor (w/ O-ring), Thrust Bearing
89D	Lab Seal Stator (w/ O-ring), Radial Bearing
89E	Lab Seal Rotor (w/ O-ring), Radial Bearing
405	Cartridge O-ring



Frame-M Cross Section

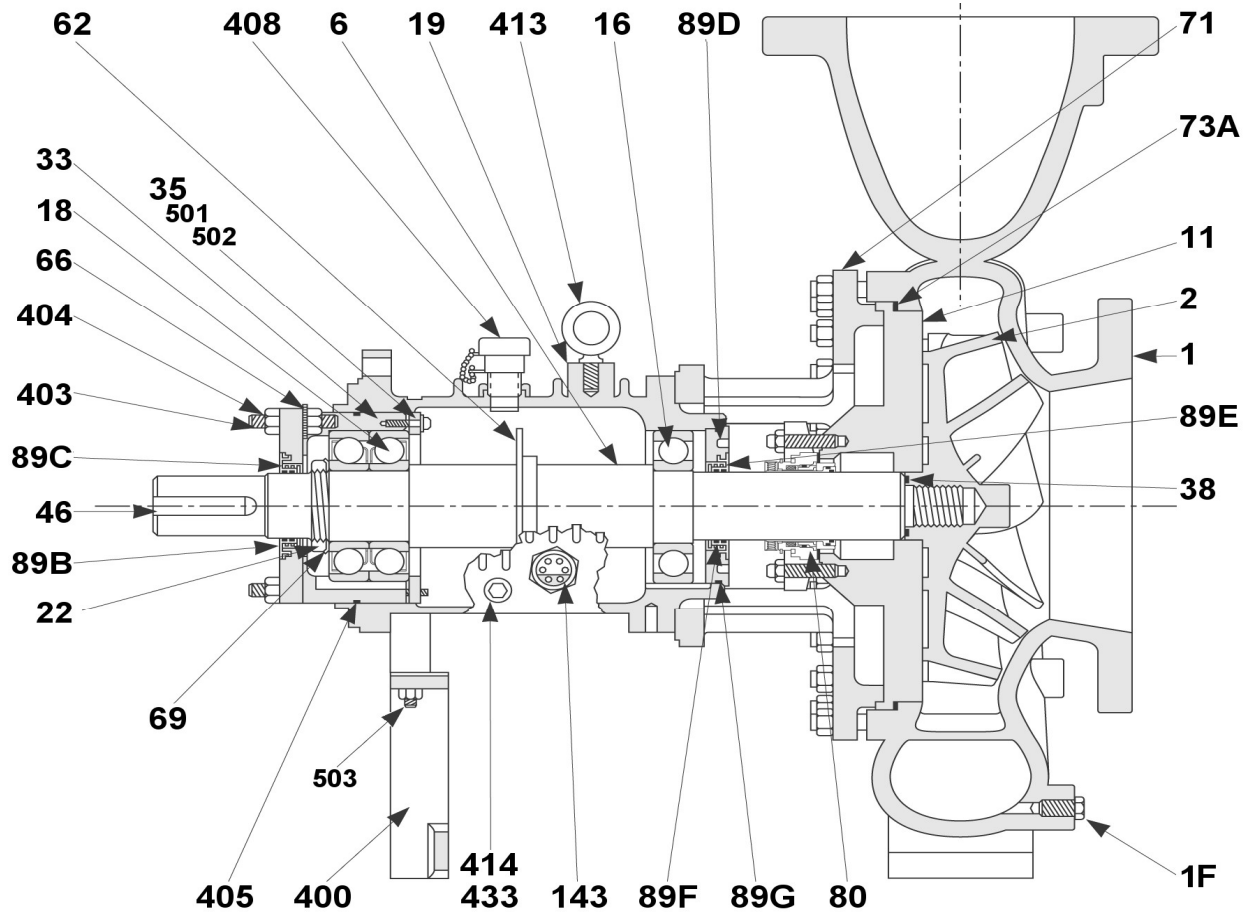

Ref.	Description	Ref.	Description	Ref.	Description
1	Casing	62	Flinger	400	Foot, Bearing Frame
1F	Drain Plug	66	Micrometer Nut	403	Stud, Cartridge
2	Impeller	69	Lockwasher, Thrust Bearing	404	Locknut, Cartridge
6	Shaft	71	Frame Adapter	405	O-Ring, Cartridge
11	Back Cover	73A	Gasket, Casing	408	Oil Filler Assembly
16	Bearing, Radial	80	Mechanical Seal	413	Bolt, Eye
18	Bearing, Thrust	89B	Seal, Labryinth Rotor, Thrust	414	Plug, Magnetic
19	Bearing Frame	89C	Seal, Labryinth O-Ring, Thrust	433	Plug, Bearing Frame
22	Locknut, Thrust Bearing	89D	Seal, Labryinth Stator, Radial	435	Plug, Casing
33	Bearing Cartridge	89E	Seal, Labryinth Rotor, Radial	501	Screw, Retainer Cover
35	Retainer Cover	89F	Seal, Lab. Rotor O-Ring, Radial	502	Washer for 501
38	O-Ring, Impeller Hub	89G	Seal, Lab. Stator O-Ring, Radial	503	Screw, Bearing Frame Foot
46	Key, Coupling	143	Oil Sight Glass		



Frame-M SPARE PARTS

Ref #1 Casing Assembly Frame-M							
Casing assemblies include bolts (13" - 16 bolts; 15" - 24 bolts) and plugs. Casing Assemblies do not include gasket (73A) or foot (by others) for center line mounting.							
Flange	Other	DI	CF8M	CD4	CN7M	HB	HC
6x8-13		Part Number for Casing Assembly					
150FF	~	637512	637518				983062
150RF	~	643076 ¹	982967				
300FF	~	801519					
300RF	~						
8x10-13		Part Number for Casing Assembly					
150FF	~	637523	637527				
150RF	~						
300FF	~						
300RF	~						
6x8-15		Part Number for Casing Assembly					
150FF	~	637492	637498	983087			
150RF	~						
300FF	~	643096					
300RF	~						
8x10-15		Part Number for Casing Assembly					
150FF	~	637503	637507	643476			
150RF	~						
300FF	~	640579 ¹					
300RF	~						
Hardware included with Casing Assembly							
Bolt*	16 or 24	637486	637486	637486	643384	643384	643384
Washer *	16 or 24	350396	1045200	1045200	1045200	1045200	1045200
Plug Tap*	1	098395	098395	098395	350664	628343	628482
Plug DR	1	098280	098280	098280	098008		981101

* Not depicted in drawing.

¹ Centerline Mount

Ref #2 Impeller Assembly Frame-M							
Impeller Assembly includes trim, balance and PTFE O-ring (38). Specify trim with order. There is a charge for retrim after shipment (981631).							
Ref #	Size	CD4	CF8M	CN7M	HB	HC	
2	6x8-13	637519					983068
	8x10-13	637528					
	6x8-15	637499					
	8x10-15	637508	644125				

Ref #6 Shaft and Rotating Element Assembly Frame-M				
Ref.#	Description	Parts/pump	Part No.	Notes
6-SA	Shaft Assembly CS/316 Includes shaft (6), Locknut (22), Key (46) and washer 69).	1	637473	
6-RE	Rotating Element CS/316 Includes shaft assembly (6-SA), bearings (16&18), cover (35), flinger (62), and screw (62a).		637472	



T: 616-241-1611 • Fx: 616-241-3752
1809 Century Avenue, Grand Rapids, Michigan 49503, U.S.A

www.blackmer.com

Frame-M SPARE PARTS

REF #11 Back Cover Assemblies Frame-M					
Back Cover Assembly does not include gasket (73a).					
Bush/Other options	DI	CF8M	CD4	CN7M	HB HC
13 inch Part Number for Back Cover Assembly					
Standard - no bush	637511	637517			983065
For bush	643079				
For Enviroseal®	801131				
With Jacket - no bush	Use SS				
For bush	Use SS				
For Enviroseal®	Use SS				
15 inch Part Number for Back Cover Assembly					
Standard - no bush	637491	637497	643475		
For bush					
For Enviroseal®	808349	808436			
With Jacket - no bush	Use SS				
For bush	Use SS	643092			
For Enviroseal®	Use SS				
Plugs* (2 included)		643380			981101
Hardware Included in assemblies			Parts/Pump	CSP	SS
*	Gland Bolt		4	350483	350591
*	Washer for bolt		4	363707	801555
*	Mounting Stud		2	637469	643376
*	Nut for stud		2	098323	098316

* Not depicted in drawing

Ref.#	Description	Parts/pump	Part No.	Notes
14	Motor Frame Adaptor (284TC - 365TC) (Optional)	1	640588	
	Includes 5-350483; 4-098277; 4-637486			
	Motor Frame Adaptor (404TC - 449TC) (Optional)		640589	
	Includes 9-350483; 4-350483; 4-637486			
16	Radial Bearing 6314 C3	1	630999	
18	Thrust Bearing (7314 BEGay)	2	630998	
19	Bearing Frame Assembly Includes bearing frame (19), sight glass (143), studs (403), oil cap (408), eyebolt (413), plugs (414&433).	1	637480	
22	Bearing Locknut N14	1	637474	
33	Thrust Bearing Cartridge Includes cartridge (33), Screws (501), washers (502), and O-ring (405).	1	637476	
35	Retainer Cover	1	634929	
38	Impeller O-ring	1	637488	
46	Key	1	360346	
62	Flinger	1	634930	
62A	Set screw for Flinger	1	350429	
66	Micrometer Nut (.50"-20) 304SS	4	637484	
69	Bearing Lockwasher W14	1	637475	
71	Frame Adapter 13" D.I. Includes jack screws (505)	1	637470	
	Frame Adapter 15" D.I. Includes jack screws (505)		981457	



Frame-M SPARE PARTS

Material Key for Wet End Gaskets (73A)

Abrv	Description	Application	Old Type
CFN	Carbon Fiber with nitrile binder (Standard)	General	197
RG0	Reinforced Graphite no binder	High Temperature	199
RPE	Reinforced PTFE	High Temperature/Pressure	196
PTFE	PTFE Style 2000 (Standard A20-HB-HC)	Chemical Resistant	2000

Ref.#	Description	Parts/pump	Part No.	Notes
73A	Casing Gaskets for FRM - 13"			
			363411	
			363412	
		1	059208	
			981932	
			099583	
	Casing Gaskets for FRM - 15"			
			637487	
			981334	
		1	981335	
		801532		
		643211		
80	Mechanical Seal - See mechanical seal pages	1		
89B	Thrust Lab Seal Rotary	1	634931	
89C	Thrust Lab Seal Rotary O-Ring (2-146 FKM)	2	360797	included in 89B
89D	Radial Lab Seal Stationary	1	634932	
89E	Radial Lab Seal Rotor	1	634931	
89F	Radial Lab Seal Rotary O-Ring (2-146 FKM)	2	360797	included in 89E
89G	Radial Lab Seal Stationary O-Ring (2-161 FKM)	1	363628	
143	Oil Sight Glass 1.00"-11.5 NPT	1	098306	
400	Bearing Frame Foot C.I.	1	634978	
401*	Side Discharge foot (Optional)	1	640581	
403	Micrometer Stud (.50"-20 x4") CS	4	637481	
404	Cartridge Locknut (.50"-20) CS	4	637485	
405	Cartridge O -Ring (2-262 Buna)	1	637477	
408	Oil Filler/Cap	1	098364	
413	Lifting Eyebolt .50"-13	1	098365	
414	Magnetic Plug .50"-14 NPT	2	098363	
433	Magnetic Plug .25"-18 NPT	1	099792	
500	Bolt for Adaptor/Bearing frame .62"-11x1.75 CS	6	637486	
501	Retainer Cover Socket Head Cap Screws	8	637478	
502	Washer for Screws	8	637479	
503	Foot Bolts (.62-11x1.50)	2	981706	
505*	Jacking screw (included in Ref 71)	3	801187	Incl'd in Ref 71
*	Temperature Monitor (Optional)	1	685361	
*	Cooling Coil (Optional)	1	643085	
*	Spiraltrak Enviroseal 316SS (Optional)	1	See Price Page 10-1301-02	

* Not depicted in drawing.



T: 616-241-1611 • Fx: 616-241-3752
1809 Century Avenue, Grand Rapids, Michigan 49503, U.S.A

www.blackmer.com



1809 Century Avenue, Grand Rapids, Michigan 49503-1530 U.S.A

Telephone: (616)241-1611 • Fax: (616)241-3752

Email: blackmer@blackmer.com • Internet: www.blackmer.com

T: 616-241-1611 • Fx: 616-241-3752

1809 Century Avenue, Grand Rapids, Michigan 49503, U.S.A

www.blackmer.com