

BLACKMER GEAR PUMP

PARTS LIST

MODELS: E1-2 and E1-4

Keep with Instructions 1901-a00 for Installation, Operation and Maintenance

960710

INSTRUCTIONS NO. 1901-a01

Section
Effective
Replaces

1901
June 2023
February 2023

E Series Seal-less Internal Gear Pumps

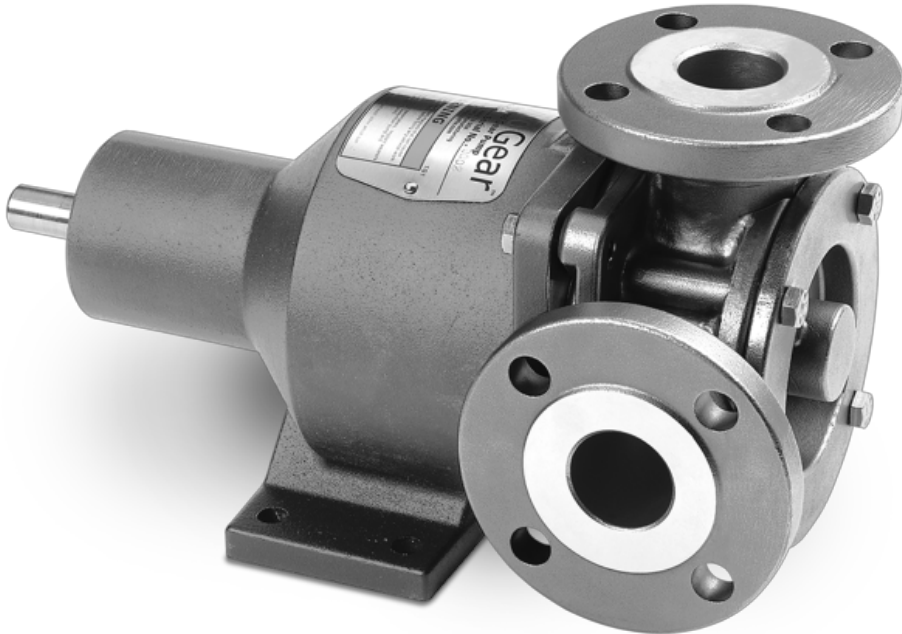

Where Innovation Flows

Blackmer

Always read the most current version of this manual before performing any work on or around this pump. The most current version of this manual is freely available on the web at www.blackmer.com

Blackmer pumps are specifically configured for your unique application conditions. Those application conditions and the details of the pump configuration were documented during the ordering process. Keep that information available in a safe place, as it may be needed when troubleshooting pump problems or when ordering spare parts or repairs.

Blackmer Gear Pumps are covered by one or more of the following patents: U.S. Patent Nos. 7549205, 7137793, 7183683, 8,608,465B2 Australian Patent No. AU2005233534B2; Korean Patent No. 10-2006-7023162; Mexican Patent No. PA/2006/011436, Russian Patent No. 2006138540(041952); China Patent No. ZL 201280031563.6; and other patents pending.

EXPLODED VIEW & PARTS LISTING

E1-2 and E1-4

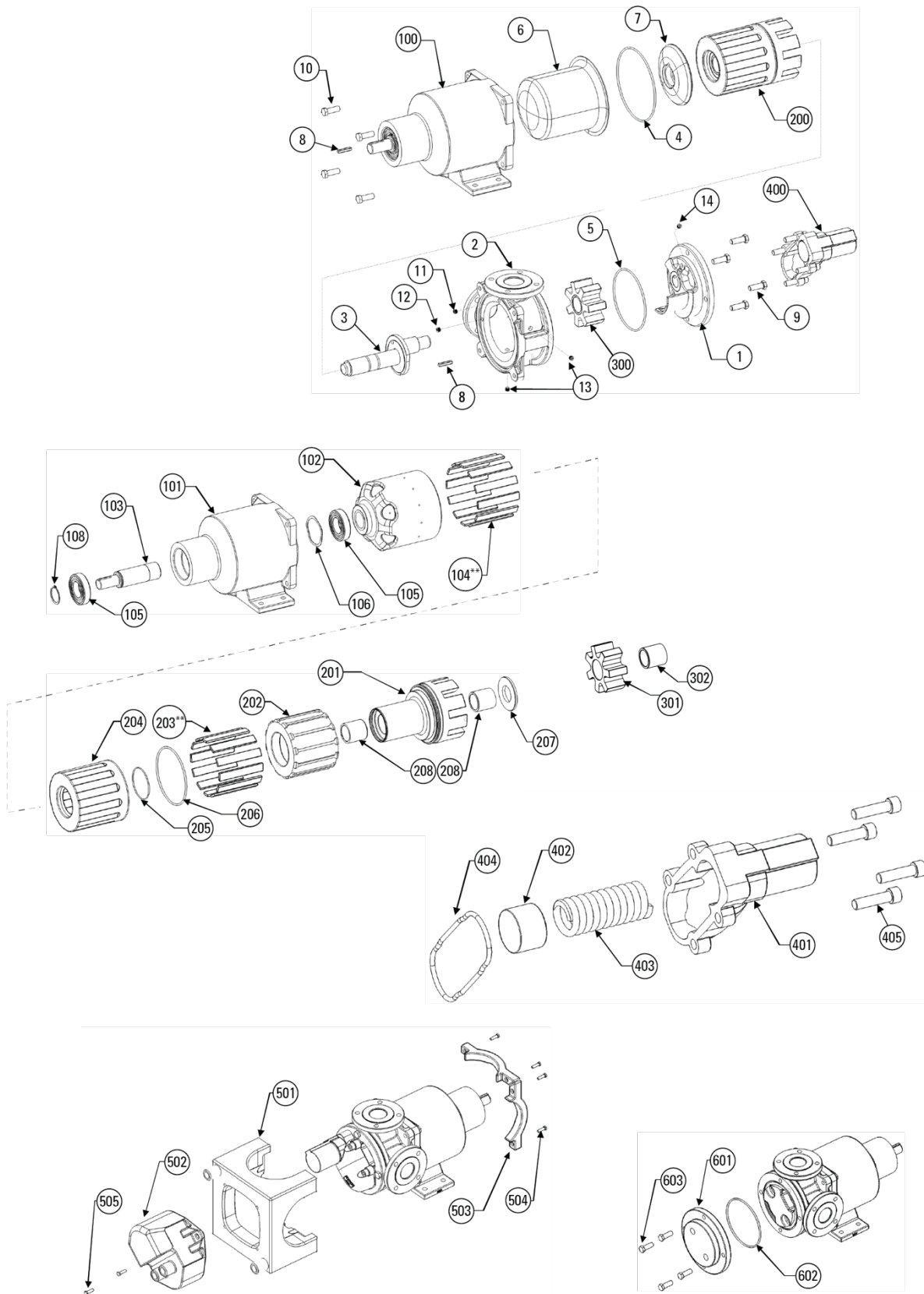

Parts Listing

MODELS E1-2 and E1-4			CARBON STEEL		STAINLESS STEEL	
Item	Description	Qty.	E1-2	E1-4	E1-2	E1-4
WET-END						
1	Head for models with RV	1	HD37		HD39	
1	Head for models without RV	1	HD5		HD6	
1	Head for models with head jacket	1	HD9		HD10	
2	Casing 1 1/2" ANSI 150# ports (90° orientation)	1	CS5		CS7	
2	Casing DN40 PN16 ports (90° orientation)	1	CS5D		CS7D	
2	Casing 1 1/2" NPT tapped ports (90° orientation)	1	CS6		CS8	
2	Casing 1 1/2" BSPT tapped ports (90° orientation)	1	CS6B		CS8B	
2	Casing 2" ANSI 150# ports (90° orientation)	1	CS46		CS47	
3	Spindle hardened	1	PN5	PN7	NA	
3	Spindle	1	PN1	PN3	PN2	PN4
4	O-ring, PFA enc. silicone, -161 size	1	HW123		HW123	
4	O-ring, FFKM 6375, -161 size	1	HW10		HW10	
4	O-ring, FEP enc. FKM, -161 size	1	HW54		HW54	
4	O-ring, FKM, -161 size	1	HW6		HW6	
5	O-ring, PFA enc. silicone, -241 size	1	HW122		HW122	
5	O-ring, FEP enc. FKM, -241 size	1	HW53		HW53	
5	O-ring, FKM, -241 size	1	HW5		HW5	
5	O-ring, FFKM 6375, -241 size	1	HW9		HW9	
6	Canister	1	CN1		CN1	
7	Support Plate	1	PP2		PP2	
	Canister-Support Plate Assembly	1	CNASM1		CNASM1	
9	Screw, 3/8-16 x 1.5" long	4	HW101		HW101	
9	Screw, 3/8-16 x 2" long	4	HW107		HW107	
10	Screw, 3/8-16 x 1.5" long	4	HW101		HW101	
11	Orifice Plug, <5000 cst	1	OF3		OF3	
12	Solid Setscrew, 3/8", SS	1	HW112		HW112	
13	Pipe Plug, 1/4" NPT, SS	1	HW14		HW14	
14	Solid Setscrew, 1/8" NPT, SS	1	908187		908188	
15	Washer, 3/8"	8	HW90		HW90	
MAGNET HOUSING ASSEMBLY						
101	Magnet Housing, with temp. probe port	1	MH11		MH11	
101	Magnet Housing, 143/5TC close coupled	1	MH38		MH38	
101	Magnet Housing, 182/4TC, 213/5TC and 254/6TC close coupled	1	MH39		MH39	
102/103/104	Outer Ring Assembly for M7L and M7M magnets (OR14, MS1, and SH1)	1	OR14-7L-S		OR14-7L-S	
102/103/104	Outer Ring Assembly for M7L and M7M magnets (OR14, MS1, and Hollow Shaft)	1	OR14-7L-14		OR14-7L-14	
102/103/104	Outer Ring Assembly for M7L and M7M magnets (OR14, MS1, and Hollow Shaft)	1	OR14-7L-18		OR14-7L-18	
102/103/104	Outer Ring Assembly for M6L and M6M magnets (OR2, MS1, and SH1)	1	OR2-6L-S		OR2-6L-S	
102/103/104	Outer Ring Assembly for M6L and M6M magnets (OR2, MS1, and Hollow Shaft)	1	OR2-6L-14		OR2-6L-14	
102/103/104	Outer Ring Assembly for M6L and M6M magnets (OR2, MS1, and Hollow Shaft)	1	OR2-6L-18		OR2-6L-18	
102/103/104	Outer Ring Assembly for M6H magnets (OR2, MS4, and SH1)	1	OR2-6H-S		OR2-6H-S	
102/103/104	Outer Ring Assembly for M6H magnets (OR2, MS4, and Hollow Shaft)	1	OR2-6H-14		OR2-6H-14	
102/103/104	Outer Ring Assembly for M6H magnets (OR2, MS4, and Hollow Shaft)	1	OR2-6H-18		OR2-6H-18	
102/103/104	Outer Ring Assembly for M6L and M6M magnets (OR2, MS1, and Hollow Shaft)	1	OR2-6L-21		OR2-6L-21	
102/103/104	Outer Ring Assembly for M6H magnets (OR2, MS4, and Hollow Shaft)	1	OR2-6H-21		OR2-6H-21	
103	Shaft, 3/4" dia	1	SH1		SH1	
8	Drive Key, 3/16" x 3/16" x 1"	1	HW4		HW4	
104	Magnet Segment, SC	**	MS4		MS4	
104	Magnet Segment, NIB	**	MS1		MS1	
105	Ball Bearing, high temp clearance (std)	2	HW222		HW222	
106	Spacer, for close-coupled shaft	1	HW195		HW195	
106	Wave Spring	1	HW16		HW16	
108	Snap Ring, for 140TC/180TC close-coupled shaft	1	HW196		HW196	
108	Snap Ring, for 210TC/250TC close-coupled shaft	1	HW197		HW197	
108	Snap Ring, for std shaft	1	HW2		HW2	
110	Magnet Housing to C-Face Adapter (143/5TC)	1	MH36		MH36	
110	Magnet Housing to C-Face Adapter (182/4TC, 213/5TC, and 254/6T)	1	MH37		MH37	
ROTATING ASSEMBLIES						
201	Rotor A/B	1	RT1	RT3	RT2	RT4
201	Rotor high visc clearance, C/F	1	RT46	RT24	RT48	RT51
201	Rotor high temp clearance, D/E	1	RT45	RT49	RT47	RT50
202	Inner Ring	1	IR1		IR1	
203	Magnet Segment, NIB	**	MS1		MS1	
203	Magnet Segment, SC	**	MS4		MS4	

MODELS E1-2 and E1-4			CARBON STEEL		STAINLESS STEEL	
Item	Description	Qty.	E1-2	E1-4	E1-2	E1-4
204	Sleeve	1	SL1		SL1	
205	O-ring, PFA enc. silicone, -042 size	1	HW116		HW116	
205	O-ring, FEP enc. FKM, -042 size	1	HW47		HW47	
205	O-ring, FFKM 6375, -042 size	1	HW12		HW12	
205	O-ring, FKM, -042 size	1	HW8		HW8	
206	O-ring, PFA enc. silicone, -155 size	1	HW124		HW124	
206	O-ring, FEP enc. FKM, -155 size	1	HW55		HW55	
206	O-ring, FKM, -155 size	1	HW7		HW7	
206	O-ring, FFKM 6375, -155 size	1	HW11		HW11	
207	Thrust Bushing, TC	1	BU44		N/A	
207	Thrust Bushings bronze	1	BU63		BU63	
207	Thrust Bushing, CG	1	BU24		BU24	
207	Thrust Bushing, ROC Carbon	1	BU118		BU118	
208	Radial bushing, TC	2	BU42		N/A	
208	Radial Bushing, bronze	2	BU56		BU56	
208	Radial Bushing, bronze, high visc clearance	2	BU68		BU68	
208	Radial bushing, CG	2	BU45		BU45	
208	Radial Bushing, CG, high visc clearance	2	BU33		BU33	
208	Radial Bushing, ROC Carbon	2	BU117		BU117	
208	Radial Bushing, ROC Carbon, high visc clearance	2	BU116		BU116	
301	Idler A/B	1	ID1	ID3	ID2	ID4
301	Idler high visc clearance, C/F	1	ID40	ID18	ID42	ID45
301	Idler high temp clearance, D/E	1	ID39	ID43	ID41	ID44
302	Radial bushing, TC	1	BU41	BU42	N/A	N/A
302	Radial bushing, bronze	1	BU55	BU57	BU55	BU57
302	Radial bushing, bronze, high visc clearance	4	BU70	BU71	BU70	BU71
302	Radial bushing, CG	1	BU1	BU45	BU1	BU45
302	Radial bushing, CG, high visc clearance	1	BU32	BU33	BU32	BU33
302	Radial Bushing, ROC Carbon	1	BU114	BU117	BU114	BU117
302	Radial Bushing, ROC Carbon, high visc clearance	1	BU115	BU116	BU115	BU116
RELIEF VALVE ASSEMBLY						
401	Valve Body	1	VB12		VB11	
402	Valve Poppet, 50 psi	1	VP24		VP5	
402	Valve Poppet, 75 psi	1	VP25		VP13	
402	Valve Poppet, 100 psi	1	VP26		VP6	
402	Valve Poppet, 125 psi	1	VP27		VP15	
402	Valve Poppet, 150 psi	1	VP28		VP7	
402	Valve Poppet, 175 psi	1	VP29		N/A	
402	Valve Poppet, 200 psi	1	VP30		N/A	
403	Valve Spring, low pressure	1	VS2		VS2	
403	Valve Spring, high pressure	1	VS4		VS4	
404	O-ring, PFA enc. silicone, -241 size	1	HW122		HW122	
404	O-ring, FEP enc. FKM, -241 size	1	HW53		HW53	
404	O-ring, FKM, -241 size	1	HW5		HW5	
404	O-ring, FFKM 6375, -241 size	1	HW9		HW9	
OPTIONS						
501	Full Jacket	1	JK8		JK8	
506	Heat Transfer Cement (gallon can)	1	AD4		AD4	
601	Head Jacket	1	HJ1		HJ1	
602	O-ring, PFA enc. silicone, -241 size	1	HW122		HW122	
603	Screw, 3/8-16 x 2" long	4	HW107		HW107	
605	1/4" NPT Thermocouple RTD Unit, NEMA 4	1	HW219		HW219	
605	1/4" NPT Thermocouple RTD Unit, NEMA 4X SS ATEX	1	HW275		HW275	
801	Rotor Puller Tool, E1-2, E1-4	1	F-00097		F-00097	

** MAGNET QUANTITIES MAY VARY DEPENDING ON PUMP CONFIGURATION

PSG Grand Rapids
1809 Century Avenue SW
Grand Rapids, MI 49503 USA
P: +1 (616) 241-1611 • F: +1 (616) 241-3752
info@blackmer.com
blackmer.com



Where Innovation Flows

PSG® reserves the right to modify the information and illustrations contained in this document without prior notice. This is a non-contractual document. 05-2018