

BLK-HW194BLACKMER GEAR PUMP

PARTS LIST

MODELS: E1-24 and E1-32

Keep with Instructions 1901-a00 for Installation, Operation and Maintenance

960711

INSTRUCTIONS NO. 1901-a02

Section	1901
Effective	June 2023
Replaces	May 2023

E Series Seal-less Internal Gear Pumps

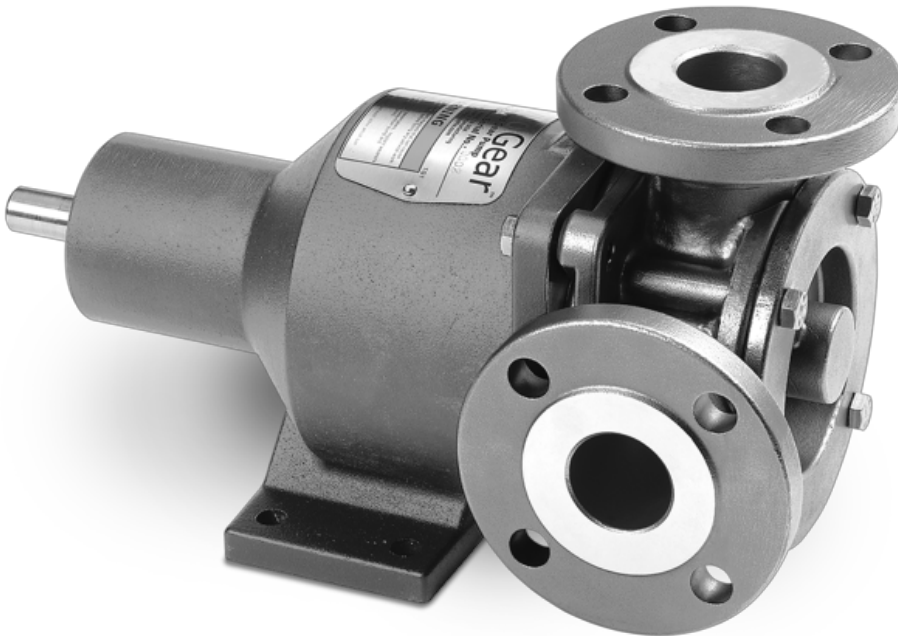

Where Innovation Flows

Blackmer

Always read the most current version of this manual before performing any work on or around this pump. The most current version of this manual is freely available on the web at www.blackmer.com

Blackmer pumps are specifically configured for your unique application conditions. Those application conditions and the details of the pump configuration were documented during the ordering process. Keep that information available in a safe place, as it may be needed when troubleshooting pump problems or when ordering spare parts or repairs.

Blackmer Gear Pumps are covered by one or more of the following patents: U.S. Patent Nos. 7549205, 7137793, 7183683, 8,608,465B2 Australian Patent No. AU2005233534B2; Korean Patent No. 10-2006-7023162; Mexican Patent No. PA/2006/011436, Russian Patent No. 2006138540(041952); China Patent No. ZL 201280031563.6; and other patents pending.

EXPLODED VIEW & PARTS LISTING

E1-24 and E1-32

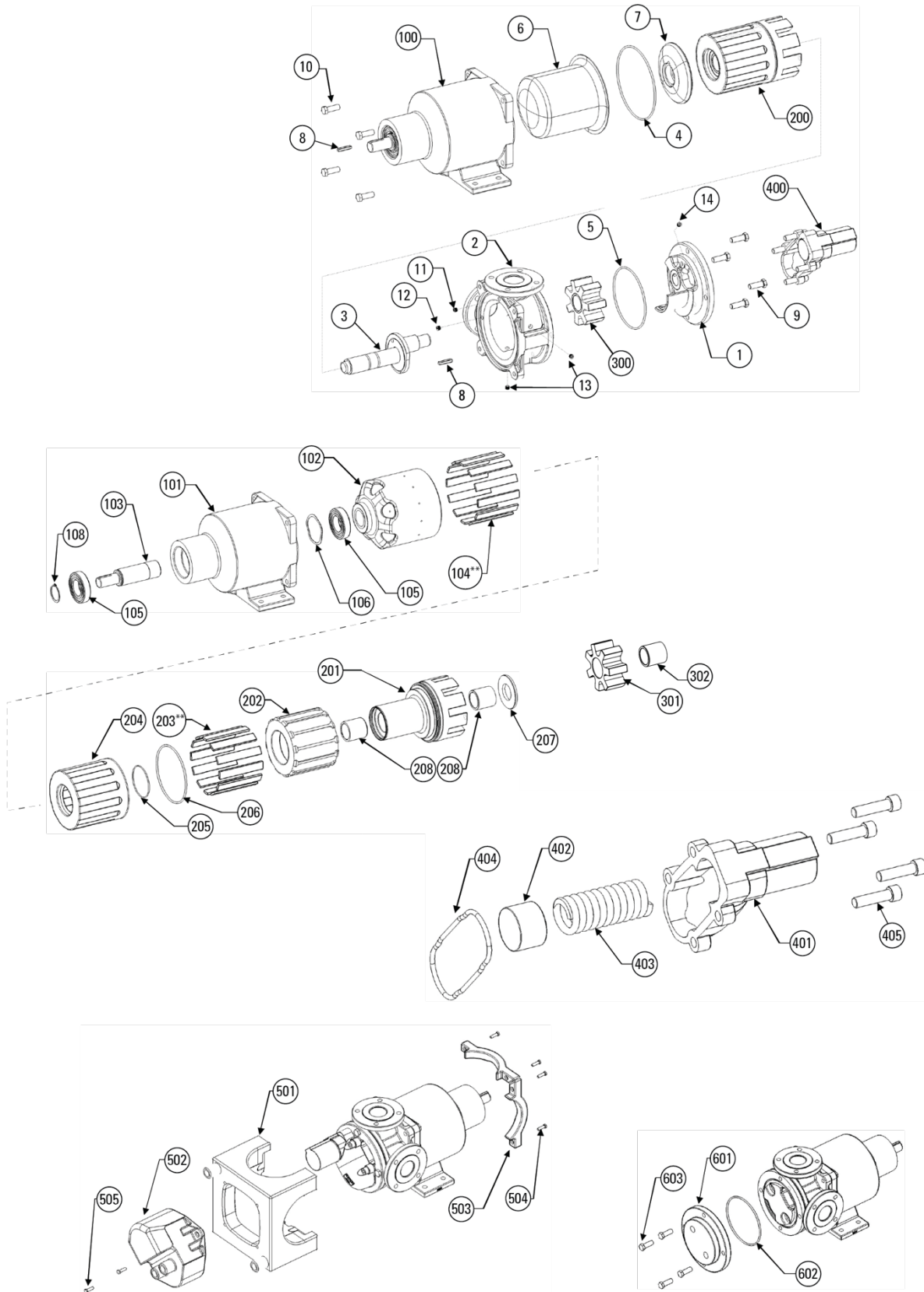

Parts Listing

MODELS E1-24 and E1-32			DUCTILE IRON		CARBON STEEL		STAINLESS STEEL	
Item	Description	Qty.	E1-24	E1-32	E1-24	E1-32	E1-24	E1-32
WET-END								
1	Head for models with RV	1	HD52		HD20		HD21	
1	Head for models with head jacket	1	HD54		HD43		HD44	
1	Head for models without RV	1	HD51		HD13		HD14	
2	Casing 2" NPT ports (90° orientation)	1	CS64		CS23		CS24	
2	Casing 2" BSPT ports (90° orientation)	1	CS64B		CS23B		CS24B	
2	Casing 2" ANSI 150# ports (90° orientation)	1	CS65		CS21		CS22	
2	Casing DN50 PN16 ports (90° orientation)	1	NA		CS21D		CS22D	
2	Casing 2" ANSI 150# ports (180° orientation)	1	CS103		CS115		CS99	
2	Casing 3" ANSI 150# ports (90° orientation)	1	NA		CS50		CS51	
3	Spindle hardened	1	PN24	PN27	PN24	PN27	NA	NA
3	Spindle	1	PN13	PN9	PN13	PN9	PN14	PN10
4	O-ring, PFA enc. silicone, -264 size	1	HW119		HW119		HW119	
4	O-ring, FEP enc. FKM, -264 size	1	HW50		HW50		HW50	
4	O-ring, FKM, -264 size	1	HW25		HW25		HW25	
4	O-ring, FFKM 6375, -264 size	1	HW135		HW135		HW135	
5	O-ring, PFA enc. silicone, -259 size	1	HW118		HW118		HW118	
5	O-ring, FEP enc. FKM, -259 size	1	HW49		HW49		HW49	
5	O-ring, FKM, -259 size	1	HW228		HW228		HW228	
5	O-ring, FFKM 6375, -259size	1	HW229		HW229		HW229	
6	Canister	1	CN3		CN3		CN3	
7	Support Plate	1	PP4		PP4		PP4	
	Canister – Support Plate Assembly	1	CNASM2		CNASM2		CNASM2	
9	Screw, 1/2-13 x 1.75" long	4	HW96		HW96		HW96	
10	Screw, 1/2-13 x 1.75" long	4	HW96		HW96		HW96	
11	Orifice Plug, <5000 cst	1	OF2		OF2		OF2	
12	Solid Setscrew, 3/8", SS	1	HW112		HW112		HW112	
13	Pipe Plug, 1/4" NPT, SS	2	HW14		HW14		HW14	
14	Solid Setscrew, 3/8", SS	1	HW112		HW112		HW112	
15	Washer, 1/2"	8	HW89		HW89		HW89	
MAGNET HOUSING ASSEMBLY								
101	Magnet Housing, with temp. probe port	1	MH10		MH10		MH10	
102/103/104	Outer Ring Assembly for M6L and M6M magnets (OR7, MS9 and SH2)	1	OR7-6L-S		OR7-6L-S		OR7-6L-S	
102/103/104	Outer Ring Assembly for M6H magnets (OR7, MS7 and SH2)	1	OR7-6H-S		OR7-6H-S		OR7-6H-S	
102/103/104	Outer Ring Assembly for M7L and M7M magnets (OR13, MS9 and SH2)	1	OR13-7L-S		OR13-7L-S		OR13-7L-S	
103	Shaft, 1-1/8" dia	1	SH2		SH2		SH2	
8	Drive Key, 1/4" x 1/4" x 1.5"	1	HW18		HW18		HW18	
104	Magnet Segment, SC	**	MS7		MS7		MS7	
104	Magnet Segment, NIB	**	MS9		MS9		MS9	
105	Ball Bearing, high temp clearance (std)	2	HW223		HW223		HW223	
106	Wave Spring	1	HW24		HW24		HW24	
108	Snap Ring	1	HW19		HW19		HW19	
ROTATING ASSEMBLIES								
201	Rotor A/B	1	RT13	RT5	RT13	RT5	RT14	RT6
201	Rotor high visc clearance, C/F	1	RT27	RT31	RT27	RT31	RT29	RT33
201	Rotor high temp clearance, D/E	1	RT26	RT30	RT26	RT30	RT28	RT32
202	Inner Ring	1	IR4		IR4		IR4	
203	Magnet Segment, NIB	**	MS9		MS9		MS9	
203	Magnet Segment, SC	**	MS7		MS7		MS7	
204	Sleeve	1	SL3		SL3		SL3	
205	O-ring, PFA enc. silicone, -042 size	1	HW116		HW116		HW116	
205	O-ring, FEP enc. FKM, -042 size	1	HW47		HW47		HW47	
205	O-ring, FFKM 6375, -042 size	1	HW12		HW12		HW12	
205	O-ring, FKM, -042 size	1	HW8		HW8		HW8	
206	O-ring, PFA enc. silicone, -258 size	1	HW121		HW121		HW121	
206	O-ring, FEP enc. FKM, -258 size	1	HW52		HW52		HW52	
206	O-ring, FKM, -257 size	1	HW26		HW26		HW26	
206	O-ring, FFKM 6375, -257 size	1	HW44		HW44		HW44	
207	Thrust Bushing, TC	1	BU31		BU31		N/A	
207	Thrust Bushings bronze	1	BU52		BU52		BU52	
207	Thrust Bushing, CG	1	BU23		BU23		BU23	
207	Thrust Bushing, ROC Carbon	1	BU123		BU123		BU123	
208	Radial Bushing, TC	2	BU40		BU40		N/A	
208	Radial bushing, bronze	2	BU59		BU59		BU59	

MODELS E1-24 and E1-32			DUCTILE IRON		CARBON STEEL		STAINLESS STEEL	
Item	Description	Qty.	E1-24	E1-32	E1-24	E1-32	E1-24	E1-32
208	Radial Bushing, bronze, high visc clearance	2	BU69		BU69		BU69	
208	Radial Bushing, CG	2	BU15		BU15		BU15	
208	Radial Bushing, CG, high visc clearance	2	BU35		BU35		BU35	
208	Radial Bushing, ROC Carbon	2	BU119		BU119		BU119	
208	Radial Bushing, ROC Carbon, high visc clearance	2	BU122		BU122		BU122	
301	Idler A/B	1	ID13	ID7	ID13	ID7	ID14	ID8
301	Idler high visc clearance, C/F	1	ID21	ID25	ID21	ID25	ID23	ID27
301	Idler high temp clearance, D/E	1	ID20	ID24	ID20	ID24	ID22	ID26
302	Radial bushing, TC	1	BU39	BU40	BU39	BU40	N/A	N/A
302	Radial bushing, bronze	1	BU58	BU59	BU58	BU59	BU58	BU59
302	Radial bushing, bronze, high visc clearance	1	BU72	BU69	BU72	BU69	BU72	BU69
302	Radial bushing, CG	1	BU19	BU15	BU19	BU15	BU19	BU15
302	Radial bushing, CG, high visc clearance	1	BU34	BU35	BU34	BU35	BU34	BU35
302	Radial Bushing, ROC Carbon	1	BU120	BU119	BU120	BU119	BU120	BU119
302	Radial Bushing, ROC Carbon, high visc clearance	1	BU121	BU122	BU121	BU122	BU121	BU122
RELIEF VALVE ASSEMBLY								
401	Valve Body	1	VB7		VB7		VB8	
402	Valve Poppet, 50 psi	1	VP18		VP18		VP4	
402	Valve Poppet, 75 psi	1	VP17		VP17		VP14	
402	Valve Poppet, 100 psi	1	VP19		VP19		VP1	
402	Valve Poppet, 125 psi	1	VP20		VP20		VP9	
402	Valve Poppet, 150 psi	1	V P21		VP21		VP2	
402	Valve Poppet, 175 psi	1	VP22		VP22		N/A	
402	Valve Poppet, 200 psi	1	VP23		VP23		N/A	
403	Valve Spring, low pressure	1	VS1		VS1		VS1	
403	Valve Spring, high pressure	1	VS5		VS5		VS5	
404	O-ring, PFA enc. silicone, -250 size	1	HW120		HW120		HW120	
404	O-ring, FEP enc. FKM, -250 size	1	HW51		HW51		HW51	
404	O-ring, FKM, -250 size	1	HW37		HW37		HW37	
404	O-ring, FFKM 6375, -250 size	1	HW159		HW159		HW159	
405	Screw Body, 1/2-13 x 2" long	4	HW33		HW33		HW33	
OPTIONS								
501	Full Jacket	1	JK1		JK1		JK1	
506	Heat Transfer Cement (gallon can)	1	AD4		AD4		AD4	
601	Head Jacket	1	HJ2		HJ2		HJ2	
602	O-ring, PFA enc. silicone, -259 size	1	HW118		HW118		HW118	
603	Screw, 1/2-13 x 2.75" long	4	HW194		HW194		HW194	
605	1/4" NPT Thermocouple RTD Unit, NEMA 4	1	HW219		HW219		HW219	
605	1/4" NPT Thermocouple RTD Unit, NEMA 4X SS ATEX	1	HW275		HW275		HW275	
801	Rotor Puller Tool Kit, E1-24 thru E1-82	1	F-00096		F-00096		F-00096	

** MAGNET QUANTITIES MAY VARY DEPENDING ON PUMP CONFIGURATION

PSG Grand Rapids
1809 Century Avenue SW
Grand Rapids, MI 49503 USA
P: +1 (616) 241-1611 • F: +1 (616) 241-3752
info@blackmer.com
blackmer.com



Where Innovation Flows

PSG® reserves the right to modify the information and illustrations contained in this document without prior notice. This is a non-contractual document. 05-2018