

BLACKMER GEAR PUMP

PARTS LIST

MODELS: E1-55, E1-69 and E1-82

Keep with Instructions 1901-a00 for Installation, Operation and Maintenance

960712

INSTRUCTIONS NO. 1901-a03

Section	1901
Effective	June 2023
Replaces	May 2023

E Series Seal-less Internal Gear Pumps

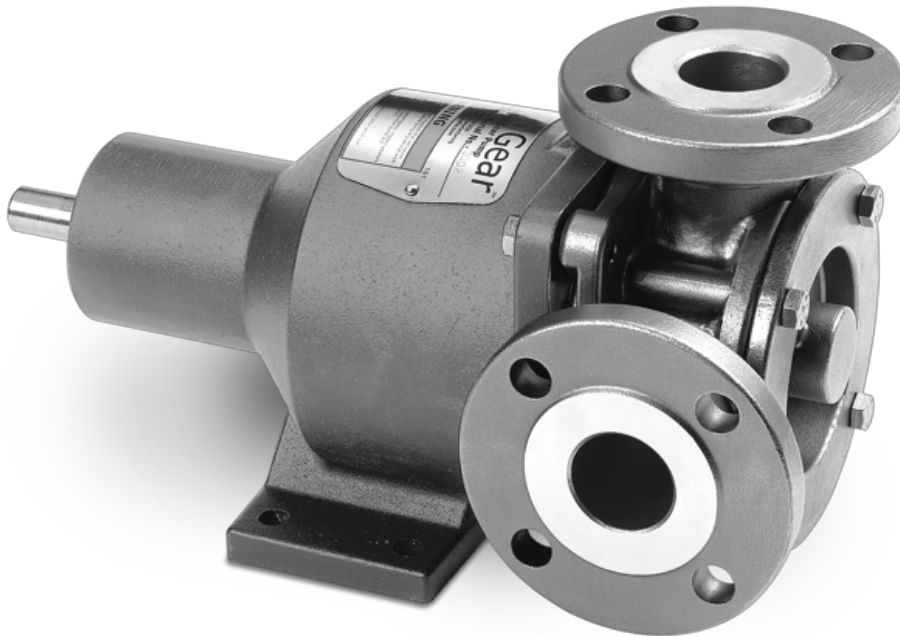

Where Innovation Flows

Blackmer

Always read the most current version of this manual before performing any work on or around this pump. The most current version of this manual is freely available on the web at www.blackmer.com

Blackmer pumps are specifically configured for your unique application conditions. Those application conditions and the details of the pump configuration were documented during the ordering process. Keep that information available in a safe place, as it may be needed when troubleshooting pump problems or when ordering spare parts or repairs.

Blackmer Gear Pumps are covered by one or more of the following patents: U.S. Patent Nos. 7549205, 7137793, 7183683, 8,608,465B2 Australian Patent No. AU2005233534B2; Korean Patent No. 10-2006-7023162; Mexican Patent No. PA/2006/011436, Russian Patent No. 2006138540(041952); China Patent No. ZL 201280031563.6; and other patents pending.

EXPLODED VIEW & PARTS LISTING

E1-55, E1-69, and E1-82

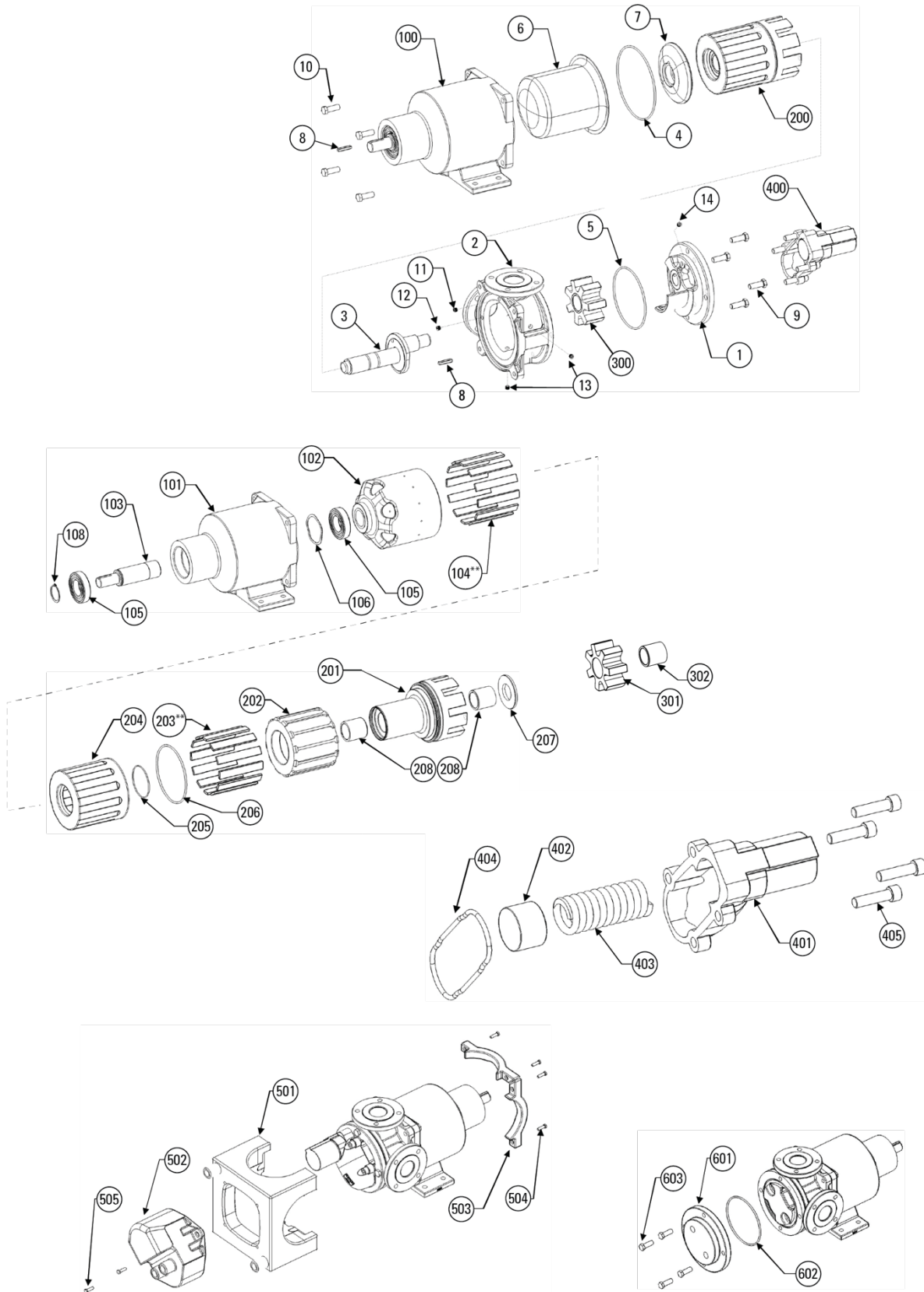

Parts Listing

MODELS E1-55, E1-69, E1-82			DUCTILE IRON			CARBON STEEL			STAINLESS STEEL		
Item	Description	Qty.	E1-55	E1-69	E1-82	E1-55	E1-69	E1-82	E1-55	E1-69	E1-82
WET-END											
1	Head for models with RV	1		HD49			HD19			HD22	
1	Head for models with head jacket	1		HD55			HD45			HD46	
1	Head for models without RV	1		HD53			HD17			HD18	
2	Casing 3" ANSI 150# ports (90° orientation)	1		CS59			CS19			CS20	
2	Casing 3" DN80 PN16 ports (90° orientation)	1		NA			CS19D			CS20D	
2	Casing 3" ANSI 150# ports (180° orientation)	1		NA			NA			CS95	
2	Casing 4" ANSI 150# ports (90° orientation)	1		CS63			CS40			CS37	
3	Spindle hardened	1	PN28	PN26	PN29	PN28	PN26	PN29	NA	NA	NA
3	Spindle	1	PN15	PN17	PN11	PN15	PN17	PN11	PN16	PN18	PN12
4	O-ring, PFA enc. silicone, -275 size	1		HW115			HW115			HW115	
4	O-ring, FEP enc. FKM, -275 size	1		HW46			HW46			HW46	
4	O-ring, FKM, -275 size	1		HW22			HW22			HW22	
4	O-ring, FFKM 6375, -275 size	1		HW75			HW75			HW75	
5	O-ring, PFA enc. silicone, -267 size	1		HW114			HW114			HW114	
5	O-ring, FEP enc. FKM, -267 size	1		HW45			HW45			HW45	
5	O-ring, FKM, -267 size	1		HW21			HW21			HW21	
5	O-ring, FFKM 6375, -267 size	1		HW74			HW74			HW74	
6	Canister	1		CN2			CN2			CN2	
7	Support Plate	1		PP3			PP3			PP3	
	Canister – Support Plate Assembly	1		CNASM3			CNASM3			CNASM3	
9	Screw, 1/2-13 x 1.75" long	4		HW96			HW96			HW96	
10	Screw, 1/2-13 x 1.75" long	4		HW96			HW96			HW96	
11	Orifice Plug, <5000 cst	1		OF1			OF1			OF1	
12	Solid Setscrew, 1/2", SS	1		HW113			HW113			HW113	
13	Pipe Plug, 1/4" NPT, SS	2		HW14			HW14			HW14	
14	Solid Setscrew, 3/8", SS	1		HW112			HW112			HW112	
15	Washer, 1/2"	8		HW89			HW89			HW89	
MAGNET HOUSING ASSEMBLY											
101	Magnet Housing, with temp. probe port	1		MH12			MH12			MH12	
102/103/104	Outer Ring Assembly for M7L and M7M magnets (OR12, MS6 and SH3)	1		OR12-7L-S			OR12-7L-S			OR12-7L-S	
102/103/104	Outer Ring Assembly for M7L and M7M magnets (OR12, MS6 and SH2)	1		OR12-7L-V			OR12-7L-V			OR12-7L-V	
102/103/104	Outer Ring Assembly for M6L and M6M magnets (OR10, MS6 and SH3)	1		OR10-6L-S			OR10-6L-S			OR10-6L-S	
102/103/104	Outer Ring Assembly for M6L and M6M magnets (OR10, MS6 and SH2)	1		OR10-6L-V			OR10-6L-V			OR10-6L-V	
102/103/104	Outer Ring Assembly for M6H magnets (OR10, MS8 and SH3)	1		OR10-6H-S			OR10-6H-S			OR10-6H-S	
102/103/104	Outer Ring Assembly for M6H magnets (OR10, MS8 and SH2)	1		OR10-6H-V			OR10-6H-V			OR10-6H-V	
103	Shaft, 1-7/16" dia	1		SH3			SH3			SH3	
103	Shaft, 1-1/8" dia	1		SH2			SH2			SH2	
8	Drive Key, 3/8" x 3/8" x 2.75" (1-7/16" shaft)	1		HW34			HW34			HW34	
8	Drive Key, 1/4" x 1/4" x 1.5" (1-1/8" shaft)	1		HW18			HW18			HW18	
104	Magnet Segment, SC	**		MS8			MS8			MS8	
104	Magnet Segment, NIB	**		MS6			MS6			MS6	
105	Ball Bearing, high temp clearance (std)	2		HW223			HW223			HW223	
106	Wave Spring	1		HW24			HW24			HW24	
108	Snap Ring	1		HW19			HW19			HW19	
ROTATING ASSEMBLIES											
201	Rotor A/B	1	RT15	RT17	RT19	RT15	RT17	RT19	RT16	RT18	RT20
201	Rotor high visc clearance, C/F	1	RT35	RT39	RT25	RT35	RT39	RT25	RT37	RT41	RT44
201	Rotor high temp clearance, D/E	1	RT34	RT38	RT42	RT34	RT38	RT42	RT36	RT40	RT43
202	Inner Ring	1		IR6			IR6			IR6	
203	Magnet Segment, NIB	**		MS6			MS6			MS6	
203	Magnet Segment, SC	**		MS8			MS8			MS8	
204	Sleeve	1		SL2			SL2			SL2	
205	O-ring, PFA enc. silicone, -042 size	1		HW116			HW116			HW116	
205	O-ring, FEP enc. FKM, -042 size	1		HW47			HW47			HW47	
205	O-ring, FFKM 6375, -042 size	1		HW12			HW12			HW12	
205	O-ring, FKM, -042 size	1		HW8			HW8			HW8	
206	O-ring, PFA enc. silicone, -267 size	1		HW114			HW114			HW114	
206	O-ring, FEP enc. FKM, -267 size	1		HW45			HW45			HW45	
206	O-ring, FKM, -267 size	1		HW21			HW21			HW21	
206	O-ring, FFKM 6375, -267 size	1		HW74			HW74			HW74	
207	Thrust Bushing, TC	1		BU28			BU28			N/A	
207	Thrust Bushings bronze	1		BU65			BU65			BU65	
207	Thrust Bushing, CG	1		BU29			BU29			BU29	

MODELS E1-55, E1-69, E1-82			DUCTILE IRON			CARBON STEEL			STAINLESS STEEL		
Item	Description	Qty.	E1-55	E1-69	E1-82	E1-55	E1-69	E1-82	E1-55	E1-69	E1-82
207	Thrust Bushing, ROC Carbon	1	BU130			BU130			BU130		
208	Radial Bushing, TC	2	BU25			BU25			N/A		
208	Radial Bushing, bronze	2	BU60			BU60			BU60		
208	Radial bushing, bronze, high visc clearance	2	BU67			BU67			BU67		
208	Radial Bushing, CG	2	BU9			BU9			BU9		
208	Radial Bushing, CG, high visc clearance	2	BU30			BU30			BU30		
208	Radial Bushing, ROC Carbon	2	BU124			BU124			BU124		
208	Radial Bushing, ROC Carbon, high visc clearance	2	BU127			BU127			BU127		
301	Idler A/B	1	ID11	ID9	ID5	ID11	ID9	ID5	ID12	ID10	ID6
301	Idler high visc clearance, C/F	1	ID29	ID33	ID19	ID29	ID33	ID19	ID31	ID35	ID38
301	Idler high temp clearance, D/E	1	ID28	ID32	ID36	ID28	ID32	ID36	ID30	ID34	ID37
302	Radial bushing, TC	1	BU26	BU27	BU25	BU26	BU27	BU25	N/A	N/A	N/A
302	Radial bushing, bronze	1	BU62	BU61	BU60	BU62	BU61	BU60	BU62	BU61	BU60
302	Radial bushing, bronze, high visc clearance	1	BU66	BU73	BU67	BU66	BU73	BU67	BU66	BU73	BU67
302	Radial bushing, CG	1	BU17	BU11	BU9	BU17	BU11	BU9	BU17	BU11	BU9
302	Radial bushing, CG, high visc clearance	1	BU36	BU37	BU30	BU36	BU37	BU30	BU36	BU37	BU30
302	Radial Bushing, ROC Carbon	1	BU126	BU125	BU124	BU126	BU125	BU124	BU126	BU125	BU124
302	Radial Bushing, ROC Carbon, high visc clearance	1	BU129	BU128	BU127	BU129	BU128	BU127	BU129	BU128	BU127
RELIEF VALVE ASSEMBLY											
401	Valve Body	1	VB5			VB5			VB6		
402	Valve Poppet, 50 psi	1	VP18			VP18			VP4		
402	Valve Poppet, 75 psi	1	VP17			VP17			VP14		
402	Valve Poppet, 100 psi	1	VP19			VP19			VP1		
402	Valve Poppet, 125 psi	1	VP20			VP20			VP9		
402	Valve Poppet, 150 psi	1	VP21			VP21			VP2		
402	Valve Poppet, 175 psi	1	VP22			VP22			N/A		
402	Valve Poppet, 200 psi	1	VP23			VP23			N/A		
403	Valve Spring, low pressure	1	VS1			VS1			VS1		
403	Valve Spring, high pressure	1	VS5			VS5			VS5		
404	O-ring, PFA enc. silicone, -261 size	1	HW117			HW117			HW117		
404	O-ring, FEP enc. FKM, -261 size	1	HW48			HW48			HW48		
404	O-ring, FKM, -261 size	1	HW36			HW36			HW36		
404	O-ring, FFKM 6375, -261 size	1	HW73			HW73			HW73		
405	Screw Body, 1/2-13 x 2" long	4	HW33			HW33			HW33		
OPTIONS											
501	Full Jacket	1	JK3			JK3			JK3		
506	Heat Transfer Cement (gallon can)	1	AD4			AD4			AD4		
601	Head Jacket	1	HJ3			HJ3			HJ3		
602	O-ring, PFA enc. silicone, -267 size	1	HW114			HW114			HW114		
603	Screw, 1/2-13 x 2.75" long	4	HW194			HW194			HW194		
605	1/4" NPT Thermocouple RTD Unit, NEMA 4	1	HW219			HW219			HW219		
605	1/4" NPT Thermocouple RTD Unit, NEMA 4X SS ATEX	1	HW275			HW275			HW275		
801	Rotor Puller Tool Kit, E1-24 thru E1-82	1	F-00096			F-00096			F-00096		

** MAGNET QUANTITIES MAY VARY DEPENDING ON PUMP CONFIGURATION

PSG Grand Rapids
1809 Century Avenue SW
Grand Rapids, MI 49503 USA
P: +1 (616) 241-1611 • F: +1 (616) 241-3752
info@blackmer.com
blackmer.com



Where Innovation Flows

PSG® reserves the right to modify the information and illustrations contained in this document without prior notice. This is a non-contractual document. 05-2018