

# BLACKMER GEAR PUMP

PARTS LIST  
MODELS: G2-82

Keep with Instructions 1902-a00 for Installation, Operation and Maintenance

960719

**INSTRUCTIONS NO. 1902-a06**

Section	1902
Effective	June 2023
Replaces	October 2022

# G Series Sealed Internal Gear Pumps

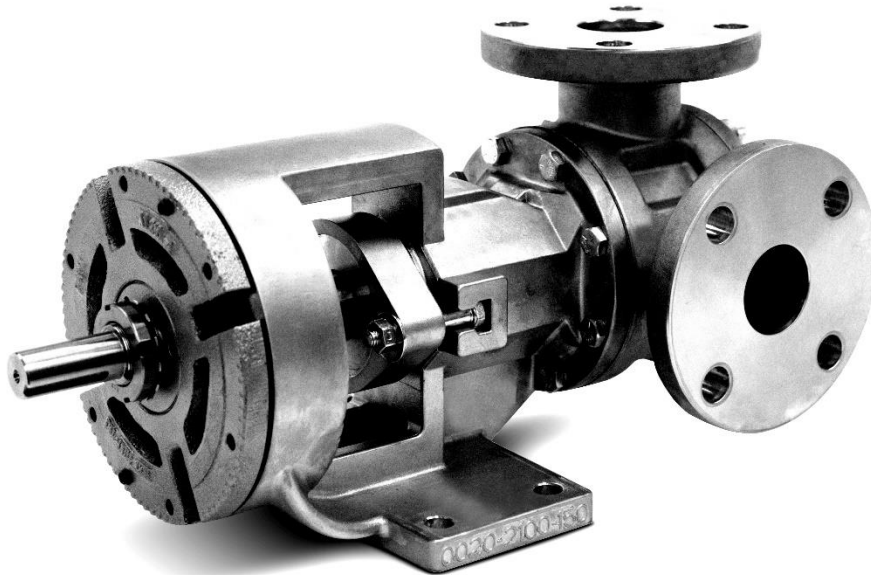

Where Innovation Flows

*Blackmer*

Always read the most current version of this manual before performing any work on or around this pump. The most current version of this manual is freely available on the web at [www.blackmer.com](http://www.blackmer.com)

Blackmer pumps are specifically configured for your unique application conditions. Those application conditions and the details of the pump configuration were documented during the ordering process. Keep that information available in a safe place, as it may be needed when troubleshooting pump problems or when ordering spare parts or repairs.

Blackmer Gear Pumps are covered by one or more of the following patents: U.S. Patent Nos. 7549205, 7137793, 7183683, 8,608,465B2 Australian Patent No. AU2005233534B2; Korean Patent No. 10-2006-7023162; Mexican Patent No. PA/2006/011436, Russian Patent No. 2006138540(041952); China Patent No. ZL 201280031563.6; and other patents pending.

# EXPLODED VIEW AND PARTS LISTING

**G2-82**

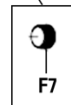
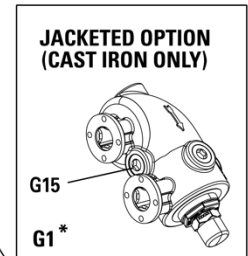
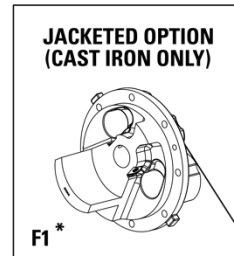
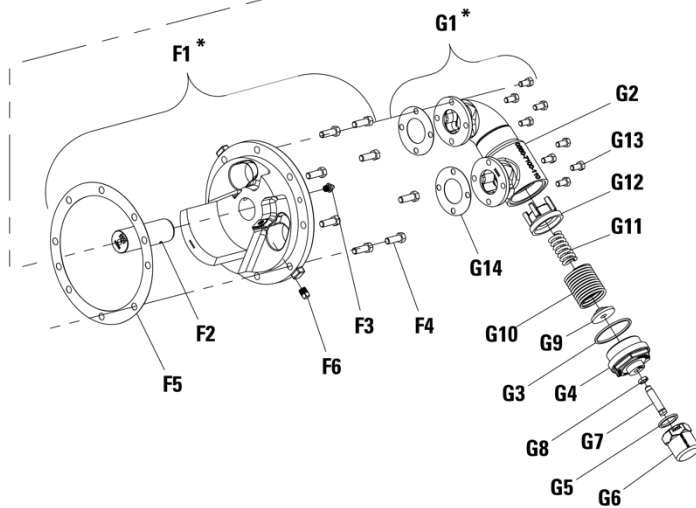
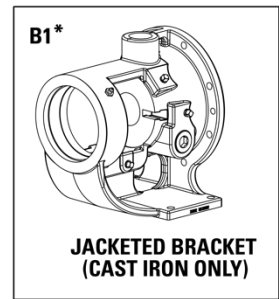
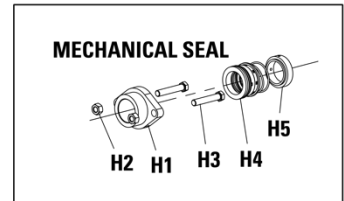
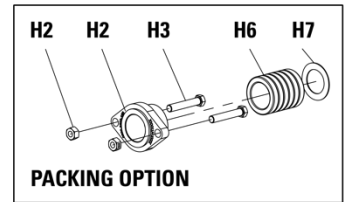
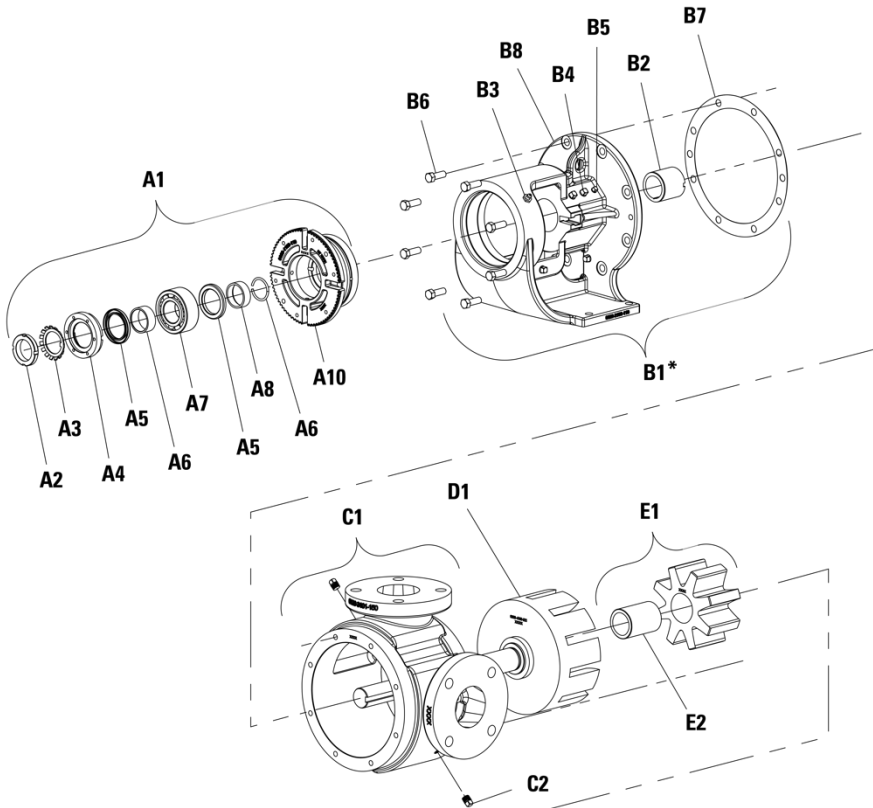

## CAST IRON

Item	Description	G2-82	Qty.	Material
A1	HOUSING, BEARING ASSEMBLY (INCLUDES A2 THRU A13)	0820-1000-110	1	CAST IRON
A2	LOCKNUT, SHAFT	099794	1	STEEL
A3	LOCKWASHER, SHAFT	0820-1720-230	1	STEEL
A4	ENDCAP, BEARING HOUSING	0820-1200-230	1	STEEL
A5	LIP SEAL, BEARING HOUSING	0820-1900-900	2	BUNA-N
A6	COLLAR, OUTER BEARING SPACER	0820-1300-230	1	STEEL
A7	BEARING	0820-1400-230	1	STEEL
A8	COLLAR, INNER BEARING SPACER	0820-1301-230	1	STEEL
A9	SEMI-ROUND RINGS	0820-1310-230	2	STEEL
A10	HOUSING, BEARING	0820-1100-110	1	CAST IRON
A11	SET SCREW (3/8"-16 X 1/2"), BEARING HOUSING (NOT SHOWN)	S57U375500WA6L7	2	STEEL
A12	SET SCREW (5/16"-18 X 5/16"), END CAP (NOT SHOWN)	S57U313313WA6L7	2	STEEL
A13	INSERT, BEARING HOUSING (NOT SHOWN)	0020-1790-400	2	NYLON
B1	BRACKET, ASSEMBLY (INCLUDES B2 THRU B8)	0820-2000-110	1	CAST IRON/CARBON GRAPHITE
		0820-2010-110	1	CAST IRON/BRONZE
	BRACKET, JACKETED, ASSEMBLY (INCLUDES B2 THRU B8)	0820-2400-110	1	CAST IRON/CARBON GRAPHITE
		0820-2410-110	1	CAST IRON/BRONZE
B2	BUSHING, BRACKET	0820-2800-300	1	CARBON GRAPHITE
		0820-2800-320	1	BRONZE
B3	FITTING, GREASE (1/8" NPT)	GRSF-013NST-230	1	STEEL
B4	PLUG, PIPE (1/4" NPT)	PLUG-025NSH-230	3	STEEL
B5	PLUG, PIPE (1/8" NPT) (USED WITH LUBRICATED BUSHING)	PLUG-013NSH-230	1	STEEL
	FITTING, GREASE (1/8" NPT) (USED WITH NON-LUBRICATED BUSHING)	GRSF-013NST-230	1	STEEL
B6	SCREWS (7/16"-14 X 1-1/4"), BRACKET	S01C438A25WA2A8	8	STEEL
B7	GASKET, BRACKET	0550-2900-950	1	INTERFACE TS-9003
B8	BRACKET	0820-2100-110	1	CAST IRON
	BRACKET, JACKETED	0820-2130-110	1	CAST IRON
C1	CASE, 3" ANSI KIT (INCLUDES B6, B7, C2, F4, F5)	0820-3001-110	1	CAST IRON
C2	PLUG, PIPE (1/4" NPT)	PLUG-025NSH-230	2	STEEL
D1	ROTOR, ASSEMBLY (A/B CLEARANCE)	0820-4000-121	1	DUCTILE IRON/STEEL
	ROTOR, ASSEMBLY (C CLEARANCE)	0820-4002-121	1	DUCTILE IRON/STEEL
	ROTOR, ASSEMBLY (D CLEARANCE)	0820-4003-121	1	DUCTILE IRON/STEEL
	ROTOR, ASSEMBLY (E CLEARANCE)	0820-4004-121	1	DUCTILE IRON/STEEL
E1	GEAR, IDLER ASSEMBLY	0820-5000-110	1	CAST IRON/CARBON GRAPHITE
		0820-5010-110	1	CAST IRON/BRONZE
E2	BUSHING, IDLER	0820-5800-300	1	CARBON GRAPHITE
		0820-5800-320	1	BRONZE
F1	HEAD, ASSEMBLY KIT (INCLUDES F2 THRU F5, G13, G14)	0820-6010-110	1	CAST IRON/STEEL
	HEAD, JACKETED, ASSEMBLY KIT (INCLUDES F2 THRU F5, G13, G14-G17)	0820-6033-110	1	CAST IRON/STEEL
F2	PIN, IDLER	0820-6200-231	1	HARDENED STEEL
F3	PLUG, PIPE (1/8" NPT) (USED WITH LUBRICATED BUSHING)	PLUG-013NSH-230	1	STEEL
	FITTING, GREASE PIN (1/8" NPT) (USED WITH NON-LUBRICATED BUSHING)	GRSF-013NST-230	1	STEEL
F4	CAPSCREW (7/16"-14 X 1-1/4"), HEAD	S01C438A25WA2A8	8	STEEL
F5	GASKET, HEAD	0550-2900-950	1	INTERFACE TS-9003
F6	PLUG, PIPE (1/4" NPT)	PLUG-025NSH-230	1	STEEL
F7	PLUG, PIPE, 1" NPT, CARBON STEEL/ZINC PLATED	PLUG-100NSH-230	1	STEEL
G1	VALVE, COVER ASSEMBLY (INCLUDES G2, G13 AND G14)	0550-7000-230	1	STEEL
	VALVE, ASSEMBLY-60 PSI (INCLUDES G2 THRU G9, G11 THRU G14)	0550-7001-110	1	CAST IRON
	VALVE, ASSEMBLY-90 PSI (INCLUDES G2 THRU G9, G11 THRU G14)	0550-7002-110	1	CAST IRON
	VALVE, ASSEMBLY-160 PSI (INCLUDES G2 THRU G10, G12 THRU G14)	0550-7003-110	1	CAST IRON
	VALVE, ASSEMBLY-200 PSI (INCLUDES G2 THRU G14)	0550-7004-110	1	CAST IRON
	VALVE, JACKETED G2, ASSEMBLY-60 PSI (INCLUDES G2 THRU G14)	0550-7031-110	1	CAST IRON
	VALVE, JACKETED G2, ASSEMBLY-90 PSI (INCLUDES G2 THRU G14)	0550-7032-110	1	CAST IRON
	VALVE, JACKETED G2, ASSEMBLY-160 PSI (INCLUDES G2 THRU G14)	0550-7033-110	1	CAST IRON
	VALVE, JACKETED G2, ASSEMBLY-200 PSI (INCLUDES G2 THRU G14)	0550-7034-110	1	CAST IRON
G2	VALVE, BODY	0550-7100-110	1	CAST IRON
	VALVE, BODY, JACKETED	0550-7130-110	1	CAST IRON
	VALVE, COVER (NOT SHOWN)	0550-7101-250	2	STAINLESS STEEL
G3	VALVE, GASKET BONNET	0240-7910-951	1	KLINGERSIL® C-4401
G4	VALVE, BONNET	0240-7200-110	1	CAST IRON
G5	VALVE, GASKET CAP	0240-7920-951	1	KLINGERSIL® C-4401

Item	Description	G2-82	Qty.	Material
G6	VALVE, CAP	0240-7300-110	1	CAST IRON
G7	VALVE, ADJUSTMENT SCREW	0240-7700-230	1	STEEL
G8	VALVE, LOCK NUT	0240-7710-230	1	STEEL
G9	VALVE, SPRING GUIDE	0240-7500-230	1	STEEL
G10	VALVE, SPRING LARGE (USED WITH 160 & 200 PSI VALVES)	0240-7602-250	1	STAINLESS STEEL
G11	VALVE, SPRING SMALL (USED WITH 60 PSI VALVES)	0240-7600-250	1	STAINLESS STEEL
	VALVE, SPRING SMALL (USED WITH 90 & 200 PSI VALVES)	0240-7601-250	1	STAINLESS STEEL
G12	VALVE, POPPET	0240-7400-110	1	CAST IRON
G13	CAPSCREW (3/8"-16 X 3/4"), VALVE	S01C375750WA2A2	8	STEEL
G14	GASKET, VALVE	0550-7900-950	2	INTERFACE TS-9003
G15	PLUG, PIPE, 3/4" NPT, CARBONE STEEL/ZINC PLATED	PLUG-075NSH-230	3	STEEL
H1	GLAND, PACKING (TYPE 1)	0820-8200-150	1	STAINLESS STEEL
	GLAND, PACKING (TYPE 9)	0820-8201-150	1	STAINLESS STEEL
H2	NUT (7/16"-14), PACKING GLAND	N04C438375AA9A1	2	STAINLESS STEEL
H3	CAPSCREW (7/16"-14), PACKING GLAND	S01C438B50CL0A1	2	STAINLESS STEEL
H4	TYPE 1, COMPONENT SEAL	0820-8000-910	1	FKM
	TYPE 9, COMPONENT SEAL	0820-8001-920	1	PTFE/NI-RESIST
H5	COLLAR, MECHANICAL SEAL ASSEMBLY	0820-8050-250	1	STAINLESS STEEL
H6	PACKING (7 RINGS)	0820-8100-925	1	PTFE - GRAPHITE
H7	WASHER, PACKING RETAINING	0820-8150-250	1	STAINLESS STEEL





PSG Grand Rapids  
1809 Century Avenue SW  
Grand Rapids, MI 49503 USA  
P: +1 (616) 241-1611 • F: +1 (616) 241-3752  
info@blackmer.com  
blackmer.com



Where Innovation Flows

---

PSG® reserves the right to modify the information and illustrations contained in this document without prior notice. This is a non-contractual document. 05-2018