

BLACKMER GEAR PUMP

PARTS LIST
MODELS: G2-133

Keep with Instructions 1902-a00 for Installation, Operation and Maintenance

960721

INSTRUCTIONS NO. 1902-a08

Section
Effective
Replaces

1902
October 2022
September 2022

G Series Sealed Internal Gear Pumps

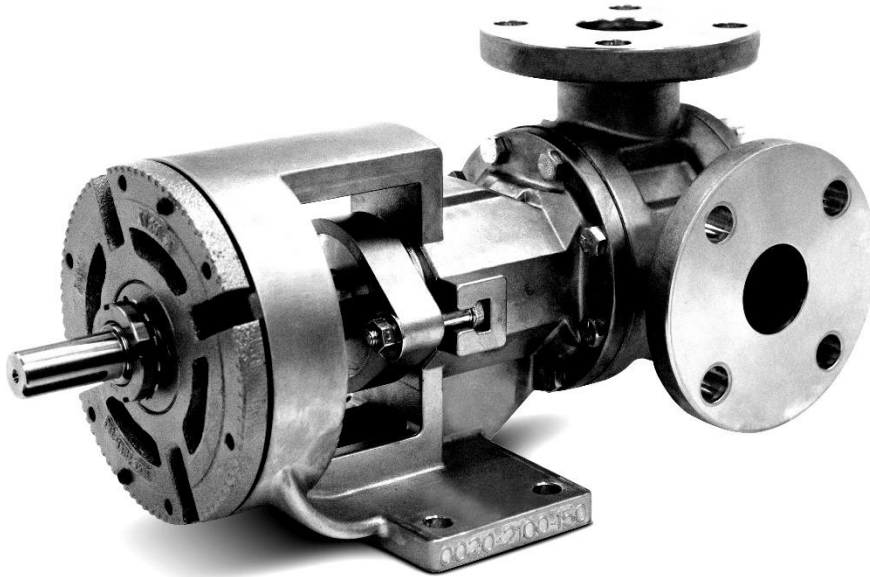

Where Innovation Flows

Blackmer

Always read the most current version of this manual before performing any work on or around this pump. The most current version of this manual is freely available on the web at www.blackmer.com

Blackmer pumps are specifically configured for your unique application conditions. Those application conditions and the details of the pump configuration were documented during the ordering process. Keep that information available in a safe place, as it may be needed when troubleshooting pump problems or when ordering spare parts or repairs.

Blackmer Gear Pumps are covered by one or more of the following patents: U.S. Patent Nos. 7549205, 7137793, 7183683, 8,608,465B2 Australian Patent No. AU2005233534B2; Korean Patent No. 10-2006-7023162; Mexican Patent No. PA/2006/011436, Russian Patent No. 2006138540(041952); China Patent No. ZL 201280031563.6; and other patents pending.

EXPLODED VIEW AND PARTS LISTING

G2-133

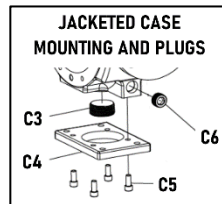
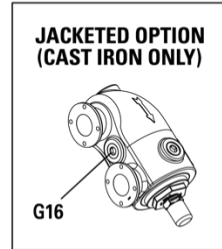
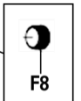
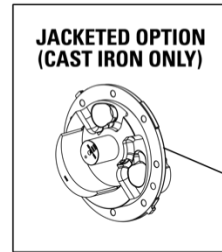
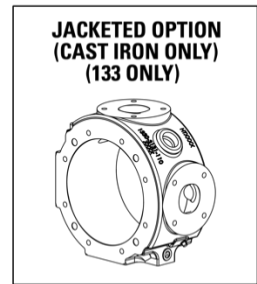
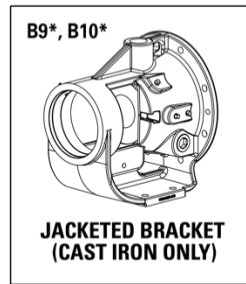
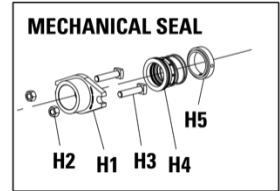
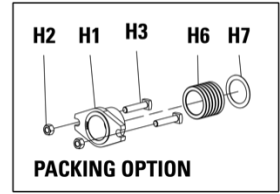
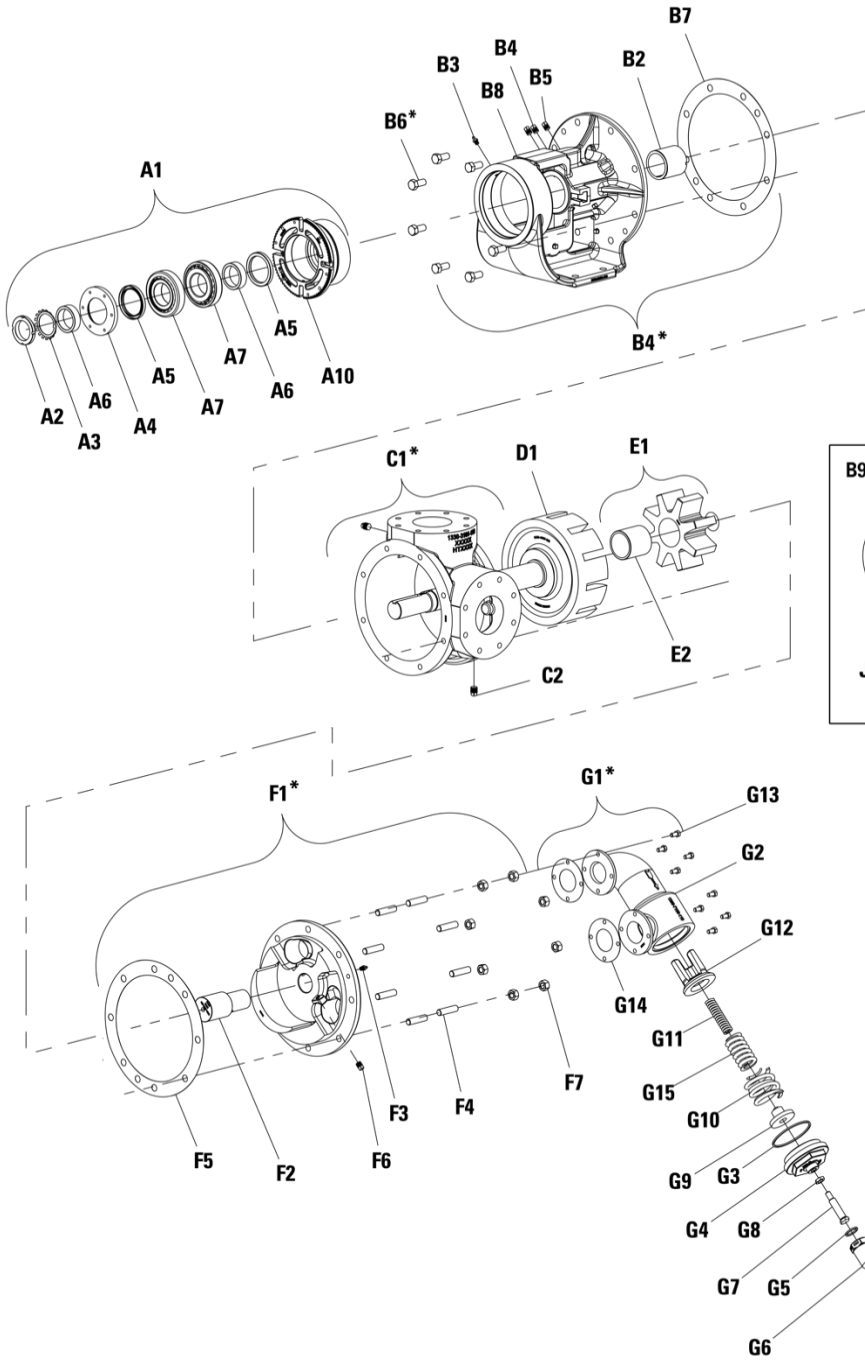

CAST IRON

Item	Description	G2-133	Qty.	Material
A1	HOUSING, BEARING ASSEMBLY (INCLUDES A2 THRU A13)	1330-1000-110	1	CAST IRON
A2	LOCKNUT, SHAFT	1330-1710-230	1	STEEL
A3	LOCKWASHER, SHAFT	1330-1720-230	1	STEEL
A4	ENDCAP, BEARING HOUSING	1330-1200-230	1	STEEL
A5	LIP SEAL, BEARING HOUSING	1330-1900-900	2	BUNA-N
A6	COLLAR, OUTER BEARING SPACER	1330-1300-230	2	STEEL
A7	BEARING	1330-1400-230	2	STEEL
A10	HOUSING, BEARING	1330-1100-110	1	CAST IRON
A11	SET SCREW (3/8"-16 X 3/4"), BEARING HOUSING (NOT SHOWN)	S57U375750WA6L7	2	STEEL
A12	SET SCREW (5/16"-18 X 5/16"), END CAP (NOT SHOWN)	S57U313313WA6L7	2	STEEL
A13	INSERT, BEARING HOUSING (NOT SHOWN)	0020-1790-400	2	NYLON
B1	BRACKET, ASSEMBLY, JACKETED CASE (INCLUDES B2 THRU B5 AND B7 THRU B10)	1330-2440-110	1	CAST IRON/CARBON GRAPHITE
		1330-2450-110	1	CAST IRON/BRONZE
	BRACKET, JACKETED, ASSEMBLY (INCLUDES B2 THRU B5 AND B7 THRU B10)	1330-2400-110	1	CAST IRON/CARBON GRAPHITE
		1330-2410-110	1	CAST IRON/BRONZE
B2	BUSHING, BRACKET	1330-2800-300	1	CARBON GRAPHITE
		1330-2800-320	1	BRONZE
B3	FITTING, GREASE (1/8" NPT)	GRSF-013NST-230	1	STEEL
B4	PLUG, PIPE (1/4" NPT)	PLUG-025NSH-230	4	STEEL
B5	PLUG, PIPE (1/4" NPT) (USED WITH LUBRICATED BUSHING)	PLUG-025NSH-230	1	STEEL
	FITTING, GREASE PIN (1/4" NPT) (USED WITH NON-LUBRICATED BUSHING)	GRSF-025NST-230	1	STEEL
B6	SCREWS (5/8"-11 X 1-1/2"), BRACKET	S01C625A50WA2A4	8	STEEL
B7	GASKET, BRACKET	1330-6900-950	1	INTERFACE TS-9003
B8	BRACKET	1330-2100-110	1	CAST IRON
	BRACKET, JACKETED	1330-2130-110	1	CAST IRON
B9	STUD, DOUBLE END 5/8"-11 X 2-1/4", CARBON STEEL/ZINC PLATED)	T09C625825WA2A2	1	STEEL
B10	NUT, HEX, 5/8"-11, CARBON STEEL/ZINC PLATED	N04C625562WA2A2	1	STEEL
C1	CASE, 4" ANSI KIT (INCLUDES B6, B7, C2, F4, F5)	1330-3001-110	1	CAST IRON
	CASE, JACKETED, 3" ANSI KIT (INCLUDES C2)	1330-3031-110	1	CAST IRON
C2	PLUG, PIPE (3/8" NPT)	PLUG-038NSH-230	2	STEEL
	PLUG, PIPE (1/4" NPT)	PLUG-025NSH-230	2	STEEL
C3	PLUG, PIPE, 1-1/2" NPT, CARBON STEEL/ZINC PLATED	PLUG-150NSH-230	1	STEEL
C4	FOOT, CASE, V-133, CARBON STEEL	1330-3400-230	1	STEEL
C5	SCREW, CAP, HEX SOCKET HEAD, 1/2"-13 X 3/4", CARBON STEEL/ZINC PLATED	S14C500500WA2A2	4	STEEL
C6	PLUG, PIPE, 1" NPT, CARBON STEEL/ZINC PLATED	PLUG-100NSH-230	2	STEEL
D1	ROTOR, ASSEMBLY (A/B CLEARANCE)	1330-4000-121	1	DUCTILE IRON/STEEL
	ROTOR, ASSEMBLY (C CLEARANCE)	1330-4002-121	1	DUCTILE IRON/STEEL
	ROTOR, ASSEMBLY (D CLEARANCE)	1330-4003-121	1	DUCTILE IRON/STEEL
E1	GEAR, IDLER ASSEMBLY	1330-5000-121	1	DUCTILE IRON/CARBON GRAPHITE
		1330-5010-121	1	DUCTILE IRON/BRONZE
E2	BUSHING, IDLER	1330-5800-300	1	CARBON GRAPHITE
		1330-5800-320	1	BRONZE
F1	HEAD, ASSEMBLY KIT (F2 THRU F7, G13, G14)	1330-6010-110	1	CAST IRON/STEEL
	HEAD, JACKETED, ASSEMBLY KIT (F2 THRU F7, G13, G14)	1330-6033-110	1	CAST IRON/STEEL
F2	PIN, IDLER	1330-6200-231	1	HARDENED STEEL
F3	PLUG, PIPE (1/8" NPT) (USED WITH LUBRICATED BUSHING)	PLUG-013NSH-230	1	STEEL
	FITTING, GREASE PIN (1/8" NPT) (USED WITH NON-LUBRICATED BUSHING)	GRSF-013NST-230	1	STEEL
F4	STUD, HEAD, (5/8"-11 X 2-1/2")	T09C625B50WA2A2	8	STEEL
F5	GASKET, HEAD	1330-6900-950	1	INTERFACE TS-9003
F6	PLUG, PIPE (1/4" NPT)	PLUG-025NSH-230	1	STEEL
F7	NUT, HEAD, (5/8"-11)	N04C625562WA2A2	8	STEEL
F8	PLUG, PIPE, 1" NPT, CARBON STEEL/ZINC PLATED	PLUG-100NSH-230	1	STEEL
G1	VALVE, COVER ASSEMBLY (INCLUDES G2, G13 AND G14)	1330-7000-230	1	STEEL
	VALVE, ASSEMBLY-50 PSI (INCLUDES G2 THRU G9, G11 THRU G14)	1330-7001-110	1	CAST IRON
	VALVE, ASSEMBLY-80 PSI (INCLUDES G2 THRU G9, G12 THRU G15)	1330-7002-110	1	CAST IRON
	VALVE, ASSEMBLY-130 PSI (INCLUDES G2 THRU G9, G11 THRU G15)	1330-7003-110	1	CAST IRON
	VALVE, ASSEMBLY-200 PSI (INCLUDES G2 THRU G15)	1330-7004-110	1	CAST IRON
	VALVE, JACKETED G2, ASSEMBLY-50 PSI (INCLUDES G2 THRU G9, G11 THRU G14)	1330-7031-110	1	CAST IRON
	VALVE, JACKETED G2, ASSEMBLY-80 PSI (INCLUDES G2 THRU G9, G12 THRU G15)	1330-7032-110	1	CAST IRON
	VALVE, JACKETED G2, ASSEMBLY-130 PSI (INCLUDES G2 THRU G9, G11 THRU G15)	1330-7033-110	1	CAST IRON
	VALVE, JACKETED G2, ASSEMBLY-200 PSI (INCLUDES G2 THRU G15)	1330-7034-110	1	CAST IRON
G2	VALVE, BODY	1330-7100-110	1	CAST IRON
	VALVE, BODY, JACKETED	1330-7130-110	1	CAST IRON

Item	Description	G2-133	Qty.	Material
	VALVE, COVER (NOT SHOWN)	1330-7101-250	2	STAINLESS STEEL
G3	VALVE, GASKET BONNET	1330-7910-951	1	KLINGERSIL® C-4401
G4	VALVE, BONNET	1330-7200-110	1	CAST IRON
G5	VALVE, GASKET CAP	1330-7920-951	1	KLINGERSIL® C-4401
G6	VALVE, CAP	1330-7300-110	1	CAST IRON
G7	VALVE, ADJUSTMENT SCREW	1330-7700-255	1	STAINLESS STEEL
G8	VALVE, LOCK NUT	1330-7710-255	1	STAINLESS STEEL
G9	VALVE, SPRING GUIDE	1330-7500-250	1	STAINLESS STEEL
G10	VALVE, SPRING LARGE (USED WITH 200 PSI VALVES)	1330-7602-250	1	STAINLESS STEEL
G11	VALVE, SPRING SMALL (USED WITH 50, 130, 200 PSI VALVES)	1330-7600-250	1	STAINLESS STEEL
G12	VALVE, POPPET	1330-7400-110	1	CAST IRON
G13	CAPSCREW (3/8"-16 X 3/4"), VALVE	S01C375750WA2A2	8	STEEL
G14	GASKET, VALVE	1330-7900-950	2	INTERFACE TS-9003
G15	VALVE, SPRING MEDIUM (USED WITH 80, 130, 200 PSI VALVES)	1330-7601-250	1	STAINLESS STEEL
G16	PLUG, PIPE, 3/4" NPT, CARBON STEEL/ZINC PLATED	PLUG-075NSH-230	3	STEEL
H1	GLAND, PACKING (TYPE 1)	1330-8200-150	1	STAINLESS STEEL
	GLAND, PACKING (TYPE 9)	1330-8201-150	1	STAINLESS STEEL
H2	NUT (5/8"-11), PACKING GLAND	N04C625562CLOA1	2	STAINLESS STEEL
H3	CAPSCREW (5/8"-11), PACKING GLAND	B01C625C00CLOA1	2	STAINLESS STEEL
H4	TYPE 1, COMPONENT SEAL	1330-8000-910	1	FKM
	TYPE 9, COMPONENT SEAL	1330-8001-920	1	PTFE/Ni-RESIST
H5	COLLAR, MECHANICAL SEAL ASSEMBLY	1330-8050-250	1	STAINLESS STEEL
H6	PACKING (7 RINGS)	1330-8100-925	1	PTFE - GRAPHITE
H7	WASHER, PACKING RETAINING	1330-8150-250	1	STAINLESS STEEL

PSG Grand Rapids
1809 Century Avenue SW
Grand Rapids, MI 49503 USA
P: +1 (616) 241-1611 • F: +1 (616) 241-3752
info@blackmer.com
blackmer.com



Where Innovation Flows

PSG® reserves the right to modify the information and illustrations contained in this document without prior notice. This is a non-contractual document. 05- 2018