

NG082C PARTS LIST

(See Instructions 601-A00 for Operation and Maintenance)

Serial # _____

ID# _____

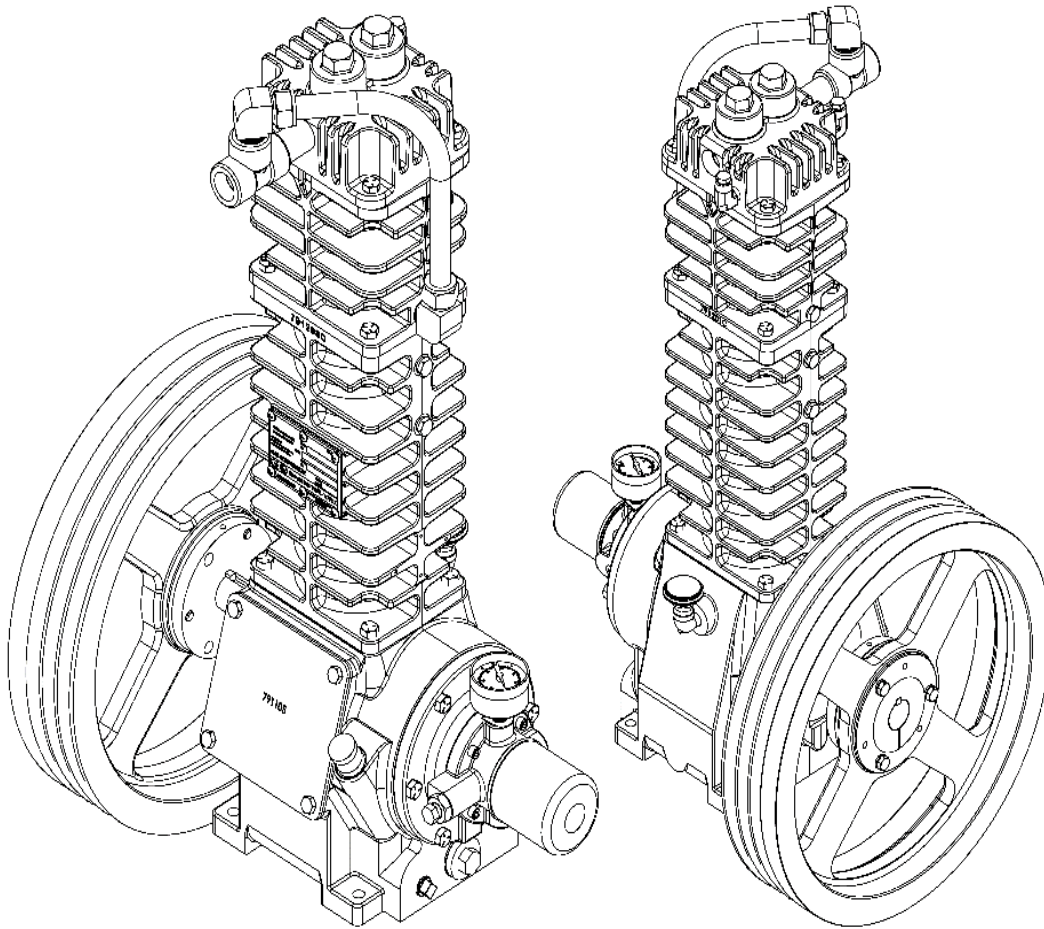

Gasket Set, Repair Kits and Special Tools

Gasket Set	FKM & Aluminum	791236
Packing Installation Tool		790536
Spanner Wrench, 1/4" Adjustable		790316
Wrench for Valve Holdown Screw		790535
Tool Kit		790199

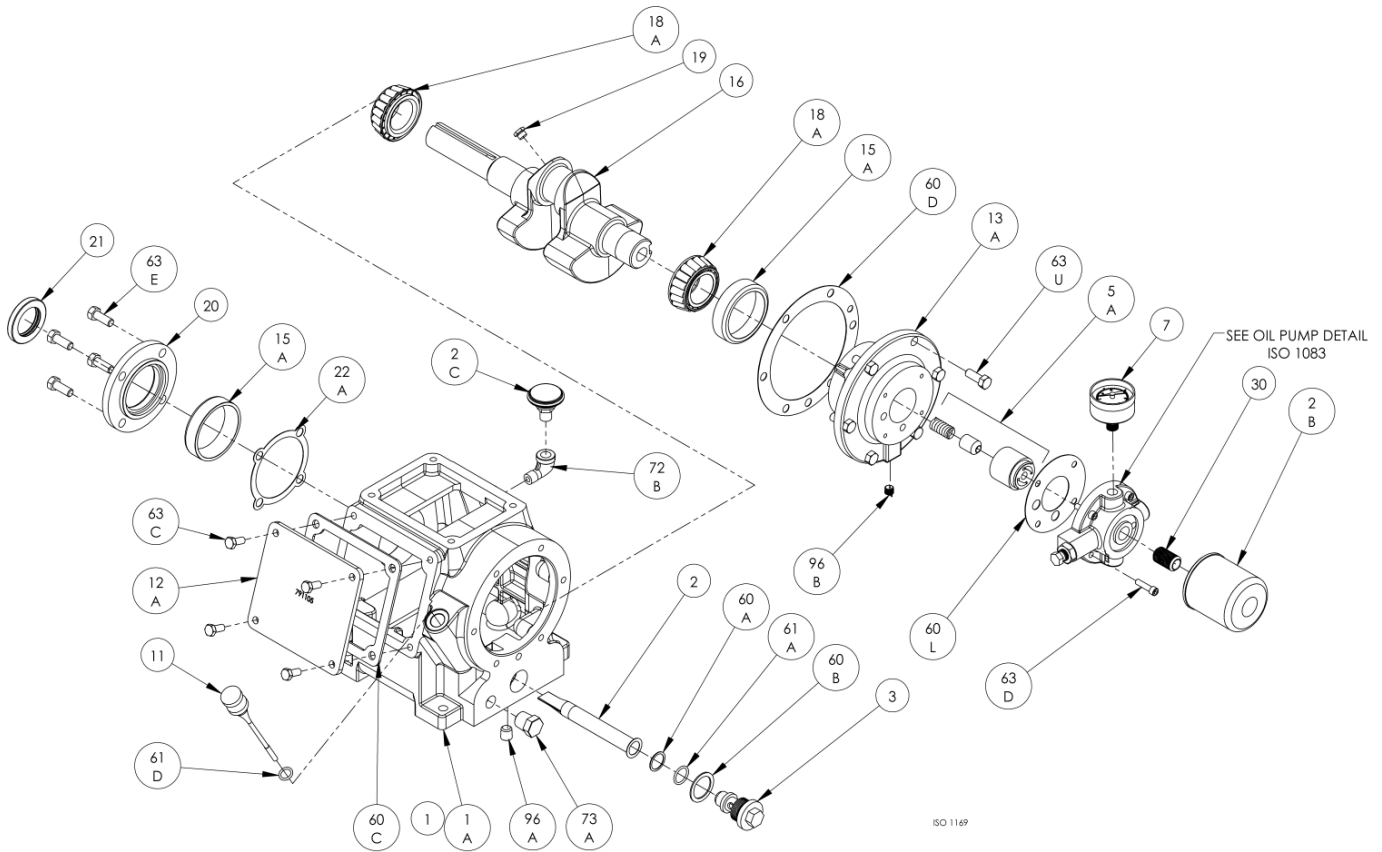

Crankcase Assembly: Models NG082B

ISO1169

Ref	Description	Qty	Part No
1	Crankcase Assembly – with Oil Filter	1	791241
1A	Crankcase	1	791202
2	Oil Intake Screen	1	792135
2B	Oil Filter	1	794726
2C	Breather Filter	1	792070
3	Oil Screen Plug	1	792145
5A	Oil Pump Kit	1	794760
7	Oil Pressure Gauge	1	790012
11	Oil Bayonet Assembly	1	792162
12A	Inspection Plate	1	791205
13A	Bearing Carrier	1	792104
15A	Bearing Cup	2	793126
16	Crankshaft Assembly (w/ 18A,19)	1	791257
18A	Bearing Cone	2	793142
19	Orifice	1	792146
20	Bearing Cover Plate	1	793106
21	Oil Seal	1	793143

Ref	Description	Qty	Part No
22A	Bearing Adjustment Shim Kit	1	793133
30	Oil Filter Fitting	1	794725
60A	Gasket - Oil Screen *	1	792136
60B	Gasket - Oil Screen Plug *	1	792123
60C	Gasket - Inspection Plate *	1	791222
60D	Gasket - Bearing Carrier Assembly*	1	792124
60L	Gasket - Oil Pump Cover *	1	794721
61A	O-Ring - Oil Screen *	1	792175
61D	O-Ring - Oil Bayonet *	1	792174
63C	Capscrew - Hex Hd	4	793116
63D	Capscrew - Soc Hd	4	790559
63E	Capscrew - Hex Hd	4	792093
63U	Capscrew - Hex Hd	6	792093
72B	Elbow	1	790453
73A	Pipe Plug	1	792166
96A	Pipe Plug	1	790488
96B	Pipe Plug	1	790309

* Included in Gasket Sets

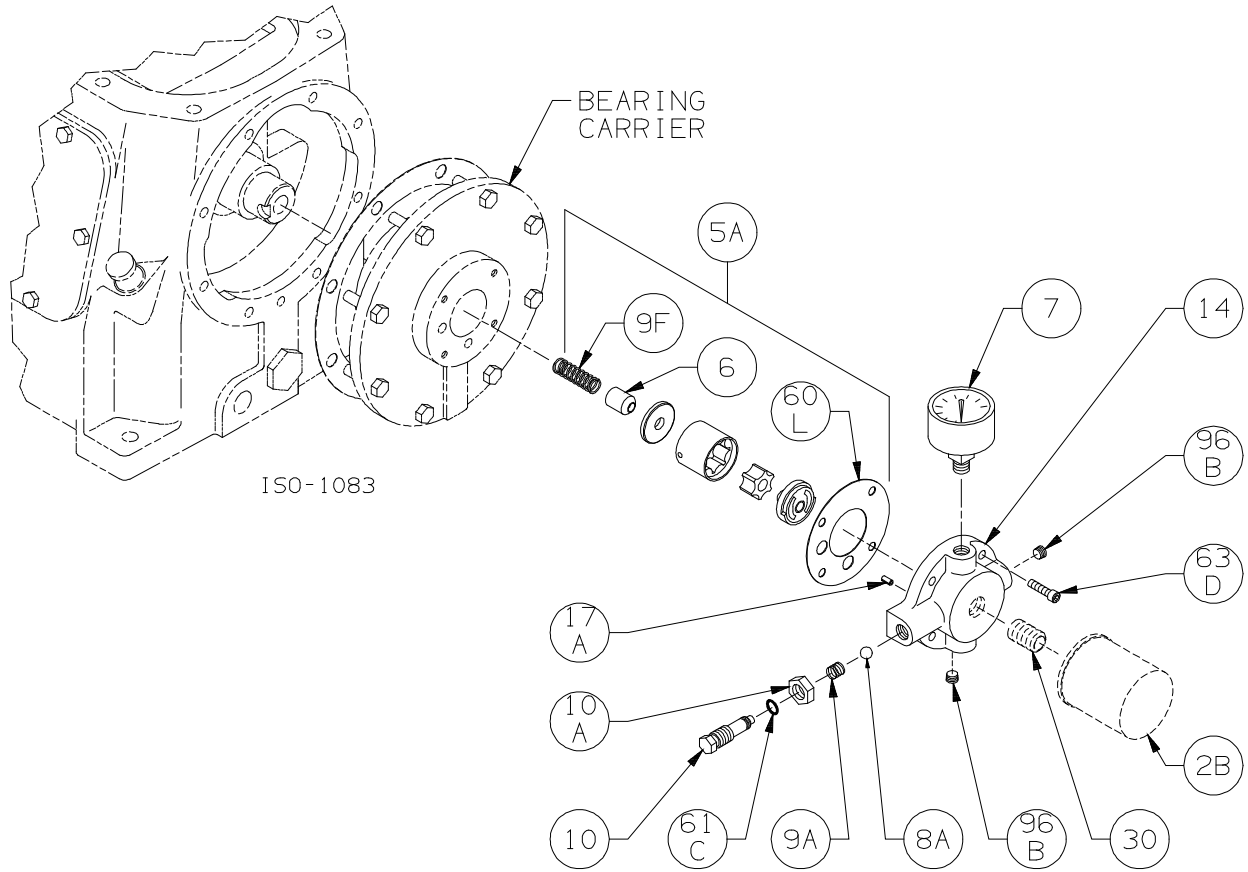

Oil Pump Detail:
Models: NG082B

Ref	Description	Qty	Part No
2B	Oil Filter	1	794726
5A	Oil Pump Kit (with 6, 9F, 60L)		794760
6	Oil Pump Cone	1	794750
7	Oil Pressure Gauge	1	790012
8A	Oil Pressure Adj. Ball	1	792154
9A	Oil Pressure Adj. Spring	1	792153
9F	Oil Pump Spring	1	794751
10	Oil Pressure Adj. Screw	1	792148
10A	Locknut	1	792152

ISO1083

Ref	Description	Qty	Part No
	Oil Pump Cover Assembly - For Filter		794764
14	Oil Pump Cover Assembly (both include 17A, 96B)	1	794763
17A	Roll Pin	1	794753
30	Oil Filter Fitting	1	794725
60L	Gasket - Oil Pump Cover *	1	794721
61C	O-Ring - Adjusting Screw *	1	792168
63D	Capscrew - Socket Head	4	790559
96B	Pipe Plug	2	790309

* Included in Gasket Sets

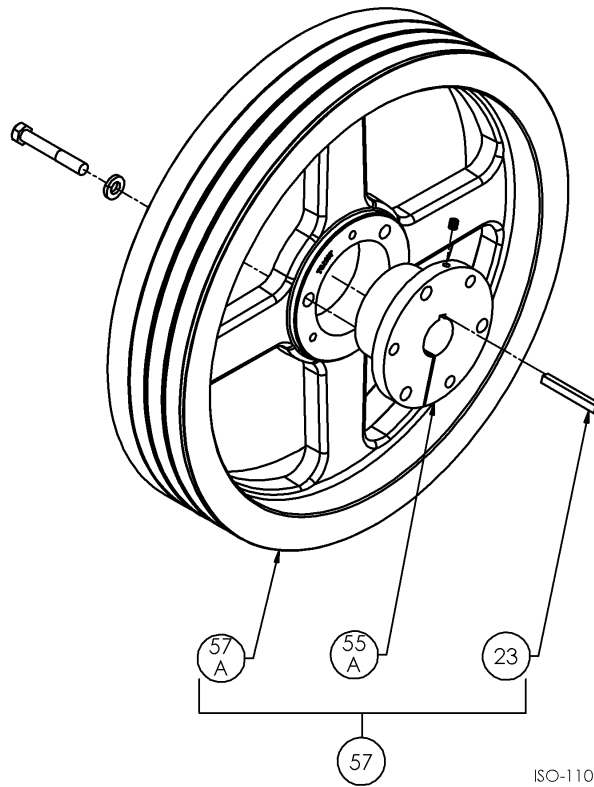
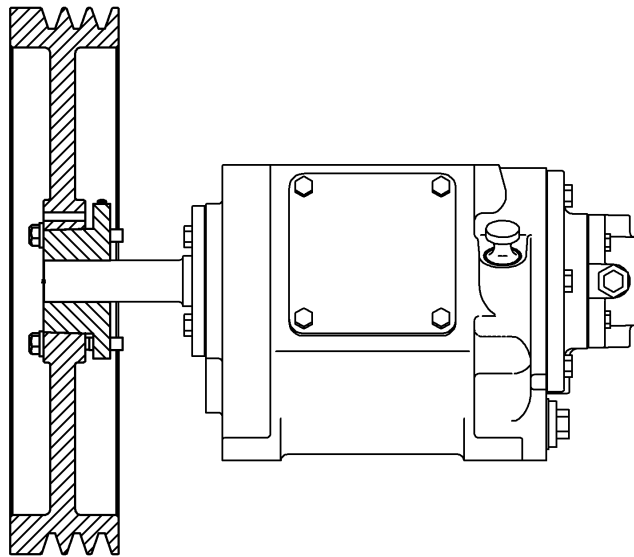

ISO-1106

Models NG082B

Ref	Description	Qty	Part No
23	Key	1	792167
55A	Hub (SF 1.25")	1	790563
57	Flywheel Assembly	1	792073
57A	Flywheel	1	792197

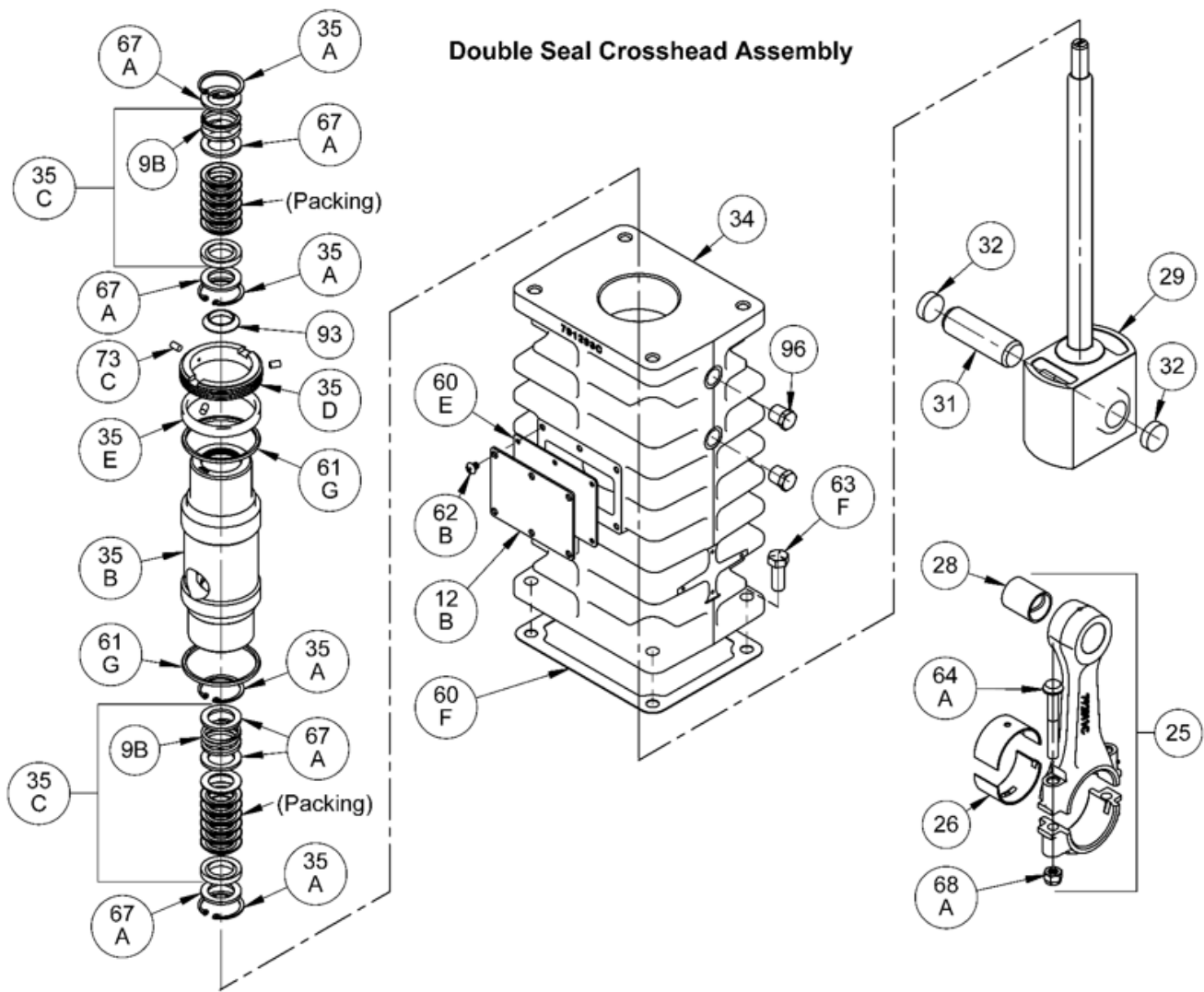

Crosshead Assembly: NG082B

ISO1170

Ref	Description	Qty	Part No
9B	Packing Spring	2	792077
12B	Inspection Plate	1	791217
25	Connecting Rod Assembly	1	792301
26	Connecting Rod Bearing	1	792012
28	Wrist Pin Bushing	1	792302
29	Crosshead Assembly	1	792501
31	Wrist Pin	1	792014
32	Wrist Pin Plug	2	792178
34	Crosshead Guide	1	791293
35A	Retainer Ring	4	793404
35B	Packing Box	1	792502
35C	Packing Set	2	793499

Ref	Description	Qty	Part No
35D	Hold-down Ring	1	793220
35E	Spacer Ring	1	793402
60E	Gasket - Inspection Plate *	1	791292
60F	Gasket - Crankcase *	1	791221
61G	O-Ring (FKM) *	2	793213
62B	Machine Screw - Inspection Plate	6	793096
63F	Capscrew - Hex Hd	4	792093
64A	Connecting Rod Bolt	2	792006
67A	Washer - Packing Box	6	792087
68A	Connecting Rod Bolt Nut	2	792005
73C	Lock Plug *	3	792030
93	Oil Deflector Ring	1	793478
96	Pipe Plug	2	908198

* Included in Gasket Sets

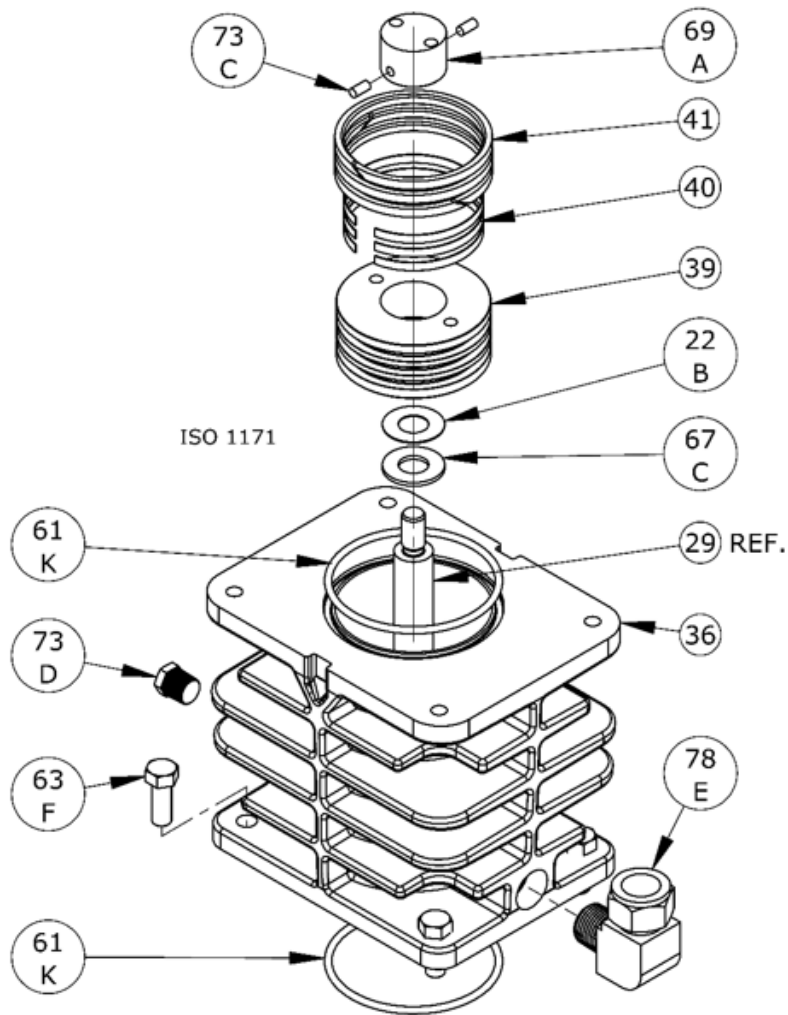

Cylinder Assembly: Model NG082B

ISO1171

Ref	Description	Qty	Part No
22B	Piston Shim - 0.015 Piston Shim - 0.007	AR	792034 792050
36	Cylinder	1	791201
39	Piston	1	792031
40	Expander	3	792022
41	Piston Ring	3	792018
61K	O-Ring (FKM)*	2	792213
63F	Capscrew - Hex Hd	4	792093
67C	Thrust Washer	1	792033
69A	Piston Nut	1	793022
73C	Lock Plug *	2	793028
73D	Pipe Plug	1	908198
78E	Tubing Elbow, Suction Pipe	1	790392

* Included in Gasket Sets

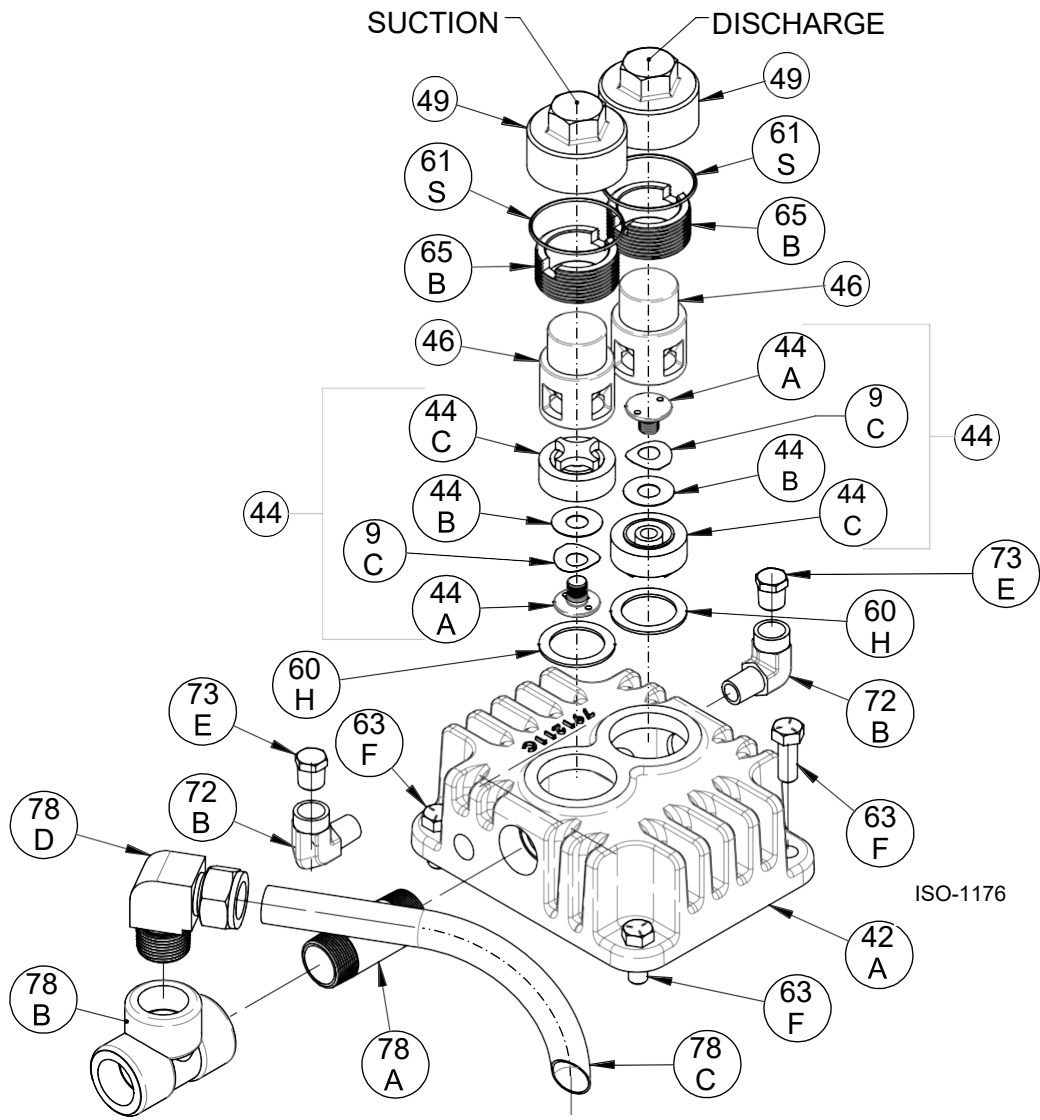

Head Assembly

ISO-1176

Ref	Description	Qty	Part No
9C	Valve Spring	2	792038
42A	Head	1	791211
44	Valve Assembly	2	792056
44A	Valve Bumper	2	792054
44B	Valve Disc	2	792037
44C	Valve Body	2	792055
46	Cage	2	792051
49	Valve Cap	2	792003
60H	Gasket - Valve *	2	792201

Ref	Description	Qty	Part No
61S	O-Ring (FKM) *	2	792308
63F	Capscrew - Hex Hd	4	792093
65B	Valve Hold Down Screw	2	792002
72B	Elbow	2	790296
73E	Pipe Plug	2	908198
78A	Nipple, Suction Pipe	1	790541
78B	Tee, Suction Pipe	1	790121
78C	Tubing, Suction Pipe	1	791295
78D	Elbow, Suction Pipe	1	790391

* Included in Gasket Sets

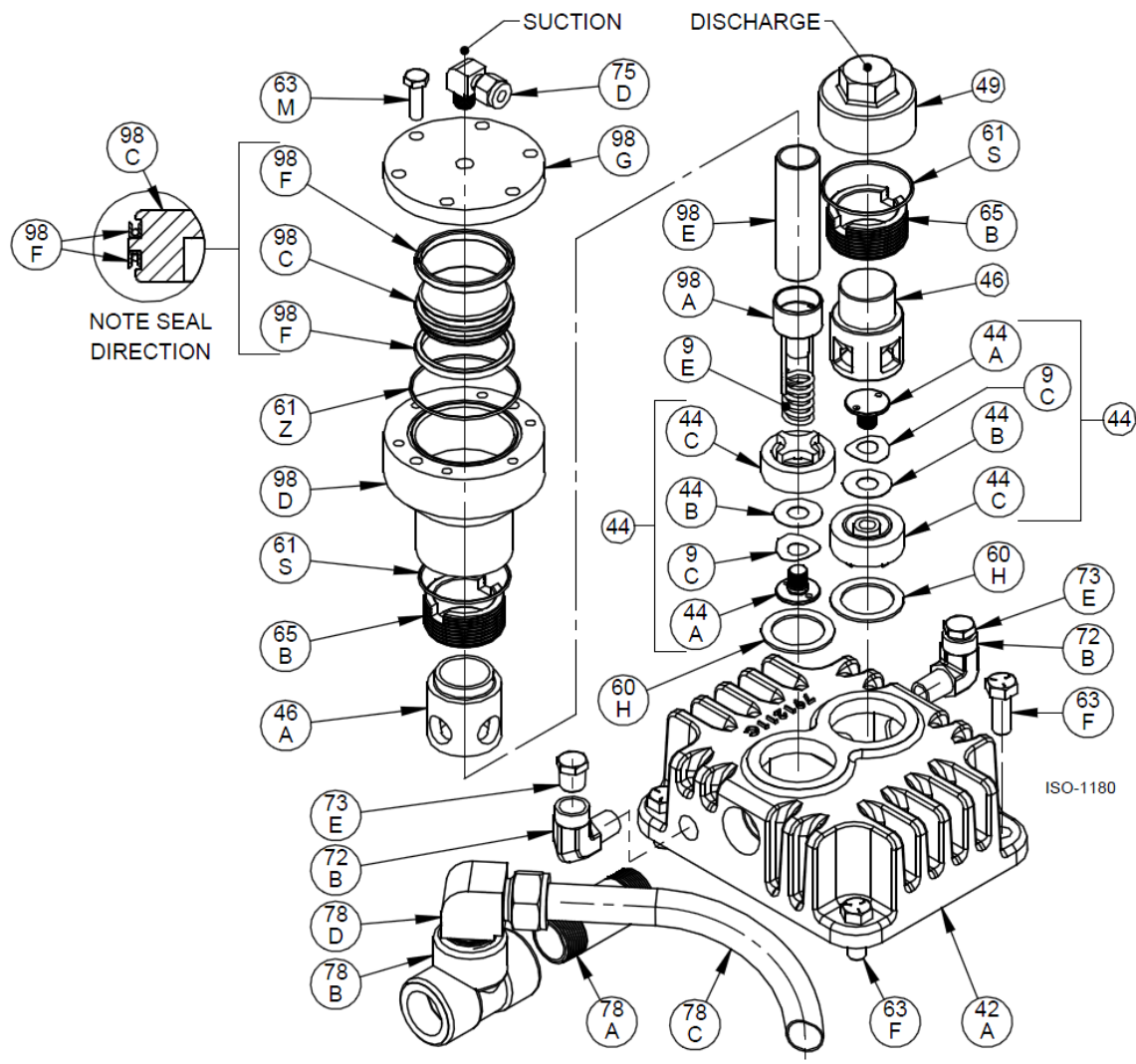

Head Assembly with Unloaders:
Model NG082

ISO-1180

Ref	Description	Qty	Part No
9C	Valve Spring	2	792038
9E	Unloader Spring	1	793293
42A	Head	1	791211
44	Valve Assembly	2	792056
44A	Valve Bumper	2	792054
44B	Valve Disc	2	792037
44C	Valve Body	2	792055
46	Cage	1	792051
46A	Cage	1	792282
49	Valve Cap	1	792003
60H	Gasket - Valve *	2	792201
61S	O-Ring (FKM) *	2	792308
61Z	O-Ring (FKM) *	1	792313
63F	Capscrew - Hex Hd	4	792093
63M	Capscrew - Hex Hd	6	797093

Ref	Description	Qty	Part No
65B	Valve Hold Down Screw	2	792002
72B	Elbow	2	790296
73E	Pipe Plug	2	908198
75D	Tube Elbow	1	790355
78A	Nipple, Suction Pipe	1	790541
78B	Tee, Suction Pipe	1	790121
78C	Tubing, Suction Pipe	1	791295
78D	Elbow, Suction Pipe	1	790391
98A	Actuator Assembly	1	792296
98C	Unloader Piston	1	793288
98D	Unloader Body	1	792286
98E	Unloader Plunger	1	793290
98F	Unloader Seal	2	792284
98G	Unloader Cap	1	793287

* Included in Gasket Sets

Suggested Spares:

Part #	Description	Qty./ Unit	Comm. Qty.	Spare Qty.
791236	Gasket Set - FKM, Iron	1	1	1
792056	Suction Valve	1		1
792056	Discharge Valve	1		1
792018	Piston Ring	3	3	3
792022	Piston Ring Expander	3	3	3
793499	Packing Set	2	2	2
794726	Oil Filter	1		6
792014	Wrist Pin	1		1
792302	Wrist Pin Bushing	1	1	1
792012	Conrod Bearing	1	1	1
The following parts would normally be required only for major compressor overhaul.				
792501	Crosshead Assembly	1		1
793142	Bearing Cone	2		2
793126	Bearing Cup	2		2
792301	Conrod Assembly	1		1
791257	Crankshaft Assembly with Bearing Cones	1		
793133	Bearing Adjustment Shim Kit	1		
794760	Oil Pump Repair Kit	1		
791201	Cylinder	1		

Notes:

Notes:

Notes: