

NGS162C PARTS LIST

(See Instructions 601-A00 for Operation and Maintenance)

Serial # _____

ID# _____

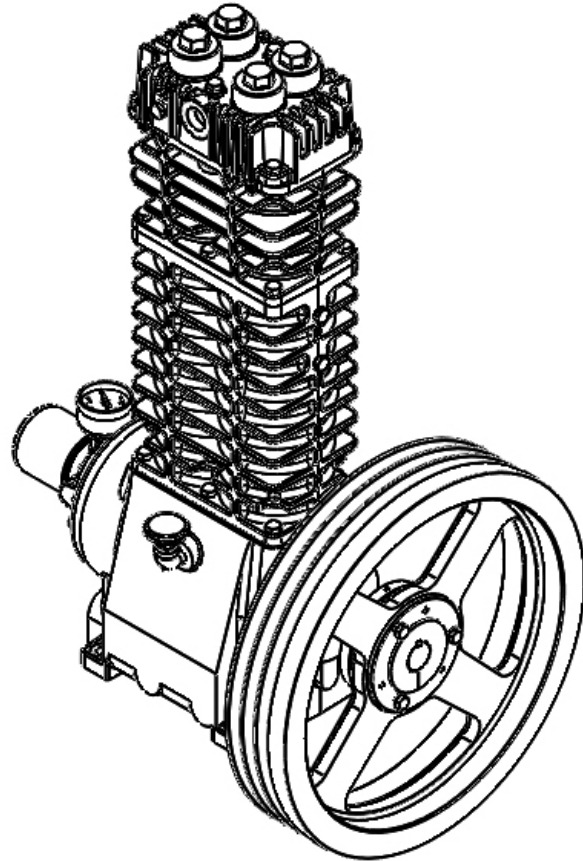
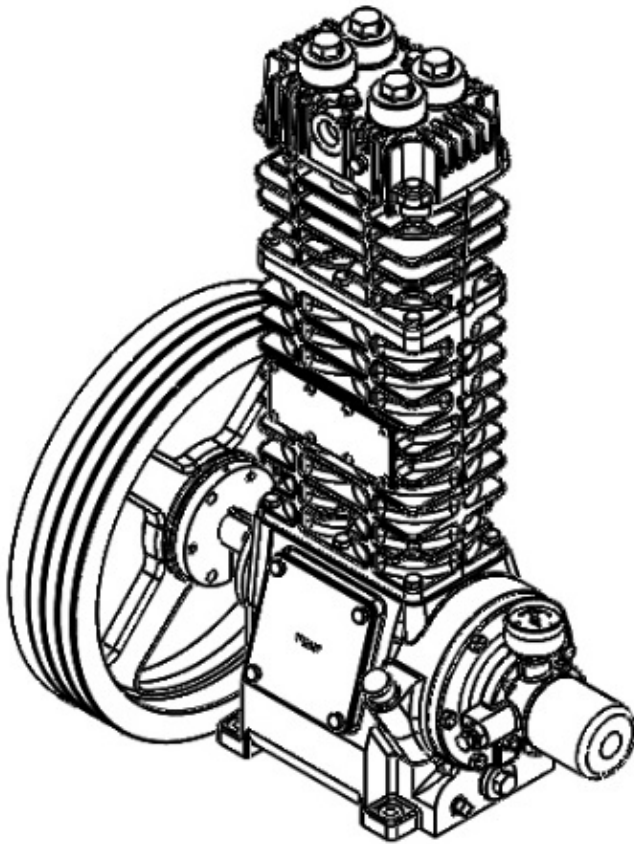

Gasket Set, Repair Kits and Special Tools

Gasket Set	FKM & Iron	792596
Packing Installation Tool		790536
Valve Hold Down Screw Tool		798016
Spanner Wrench, 1/4" Adjustable		790316
Wrench for Valve Hold Down Screw		790535
Piston Tool		798003
Tool Kit		790199

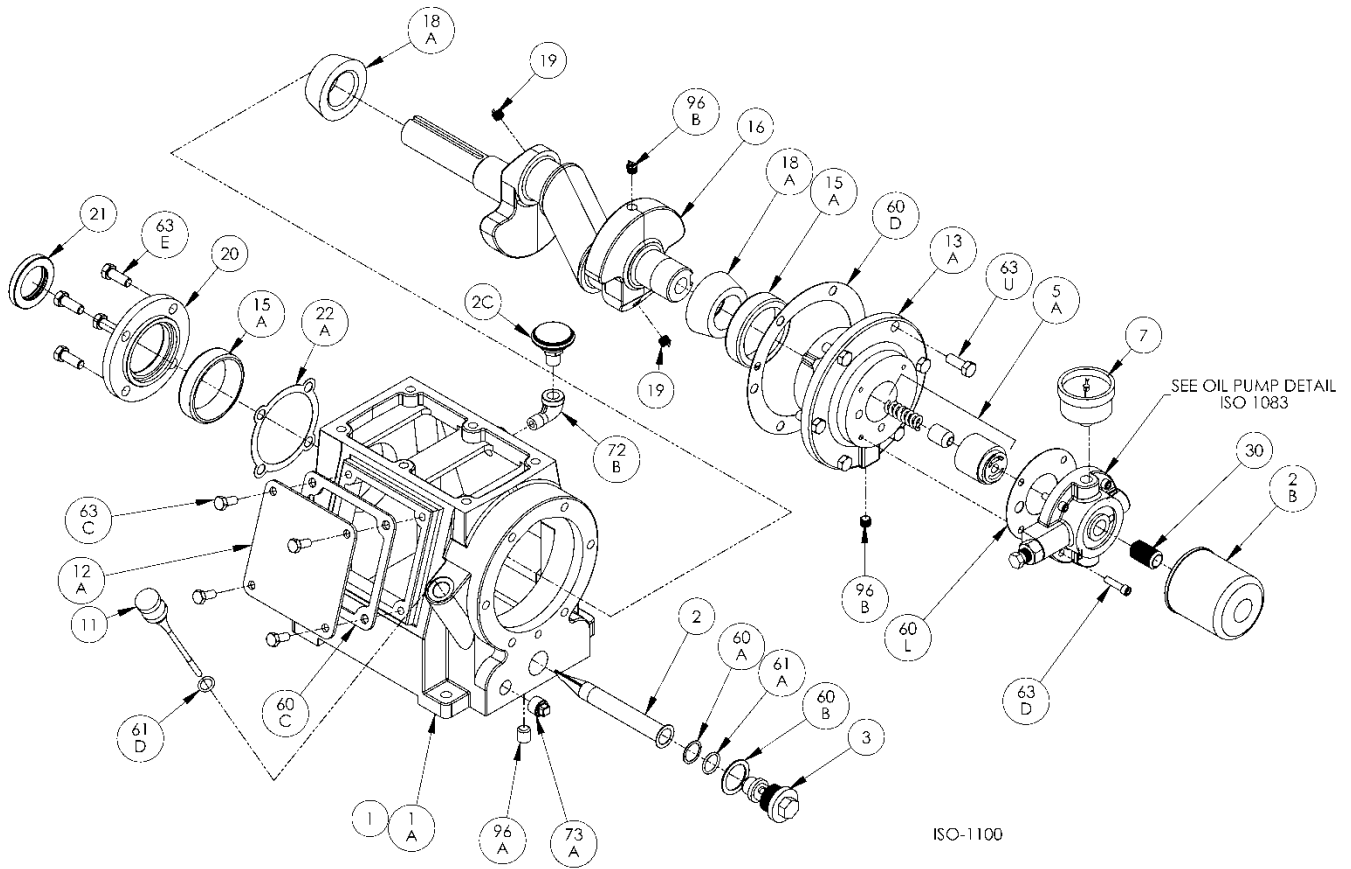

Crankcase: ISO1100

Ref	Description	Qty	Part No
1	Crankcase Assembly	1	792100
1A	Crankcase	1	792102
2	Oil Intake Screen	1	792135
2B	Oil Filter	1	794726
2C	Breather Filter	1	792070
3	Oil Screen Plug	1	792145
5A	Oil Pump Kit	1	794760
7	Oil Pressure Gauge	1	790012
11	Oil Bayonet Assembly	1	792162
12A	Inspection Plate	1	792105
13A	Bearing Carrier	1	792104
15A	Bearing Cup	2	793126
16	Crankshaft Assembly (w\ 18A,19,96B)	1	792157
18A	Bearing Cone	2	793142
19	Orifice	2	792146
20	Bearing Cover Plate	1	793106
21	Oil Seal	1	793143

Ref	Description	Qty	Part No
22A	Bearing Adjustment Shim Kit	1	793133
30	Oil Filter Fitting	1	794725
60A	Gasket - Oil Screen *	1	792136
60B	Gasket - Oil Screen Plug *	1	792123
60C	Gasket - Inspection Plate *	1	792122
60D	Gasket - Bearing Carrier Assy*	1	792124
60L	Gasket - Oil Pump Cover *	1	794721
61A	O-Ring - Oil Screen *	1	792175
61D	O-Ring - Oil Bayonet *	1	792174
63C	Capscrew - Hex Hd	4	793116
63D	Capscrew - Soc Hd	4	790559
63E	Capscrew - Hex Hd	4	792093
63U	Capscrew - Hex Hd	6	792093
72B	Elbow	1	790453
73A	Pipe Plug	1	792166
96A	Pipe Plug	1	790488
96B	Pipe Plug	2	790309

* Included in Gasket Sets

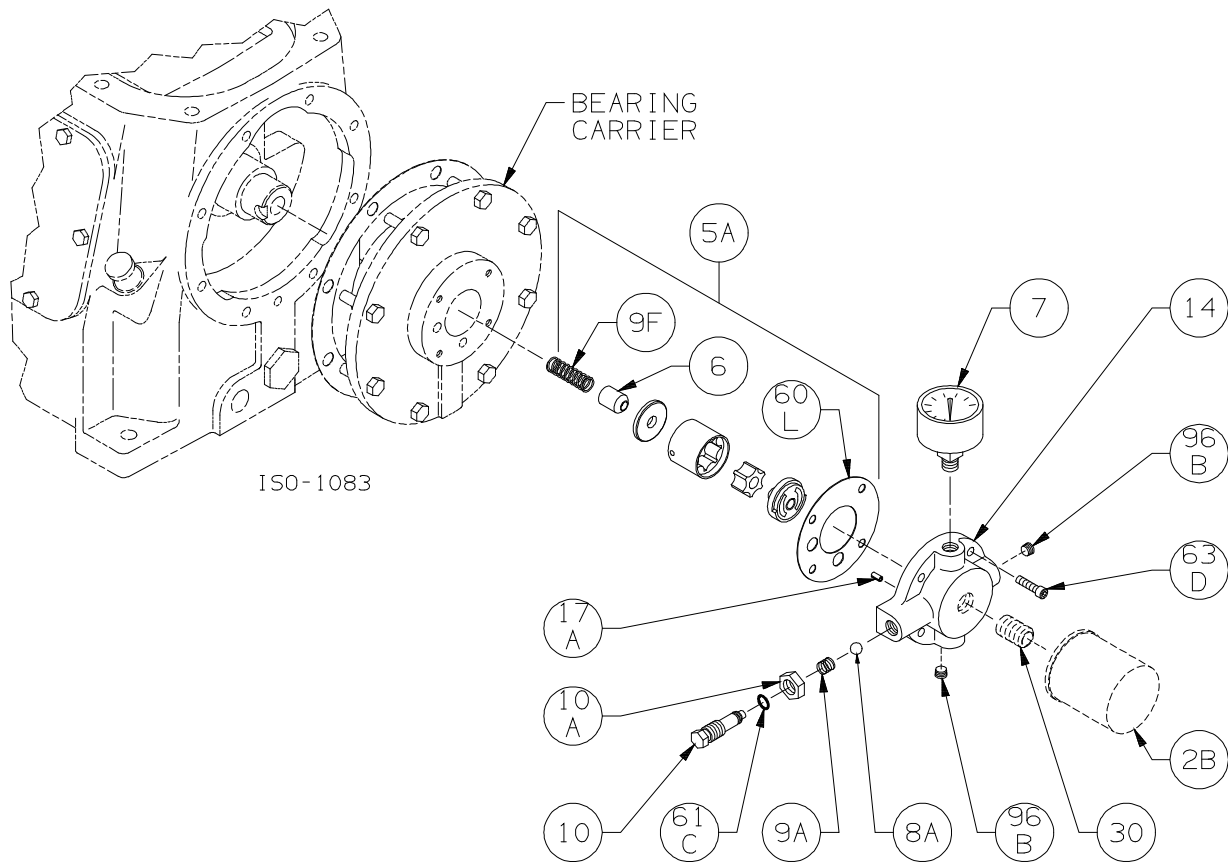

Oil Pump

Ref	Description	Qty	Part No
2B	Oil Filter	1	794726
5A	Oil Pump Kit (with 6, 9F, 60L)		794760
6	Oil Pump Cone	1	794750
7	Oil Pressure Gauge	1	790012
8A	Oil Pressure Adj. Ball	1	792154
9A	Oil Pressure Adj. Spring	1	792153
9F	Oil Pump Spring	1	794751
10	Oil Pressure Adj. Screw	1	792148
10A	Locknut	1	792152

ISO1083

Ref	Description	Qty	Part No
	Oil Pump Cover Assembly - For Filter		794764
14	Oil Pump Cover Assembly (includes 17A, 96B)	1	794763
17A	Roll Pin	1	794753
30	Oil Filter Fitting	1	794725
60L	Gasket - Oil Pump Cover *	1	794721
61C	O-Ring - Adjusting Screw *	1	792168
63D	Capscrew - Socket Head	4	790559
96B	Pipe Plug	2	790309

* Included in Gasket Sets

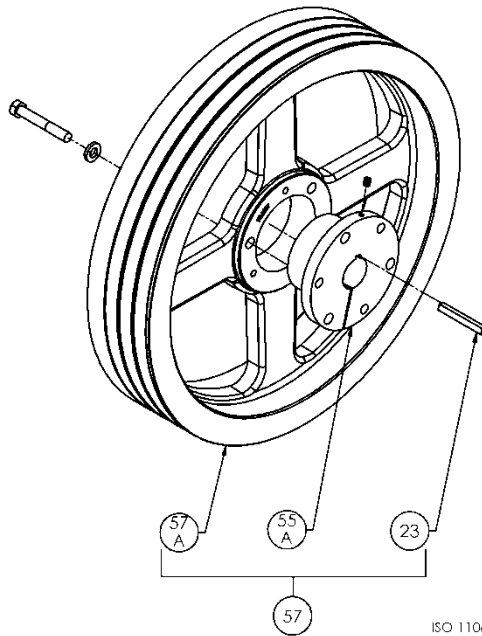
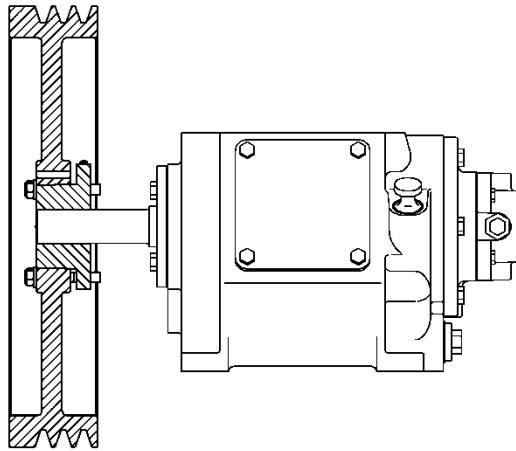

Flywheel

Ref	Description	Qty	Part No
23	Key	1	792167
55A	Hub (SF 1.25")	1	790563
57	Flywheel Assembly	1	792073
57A	Flywheel	1	792197

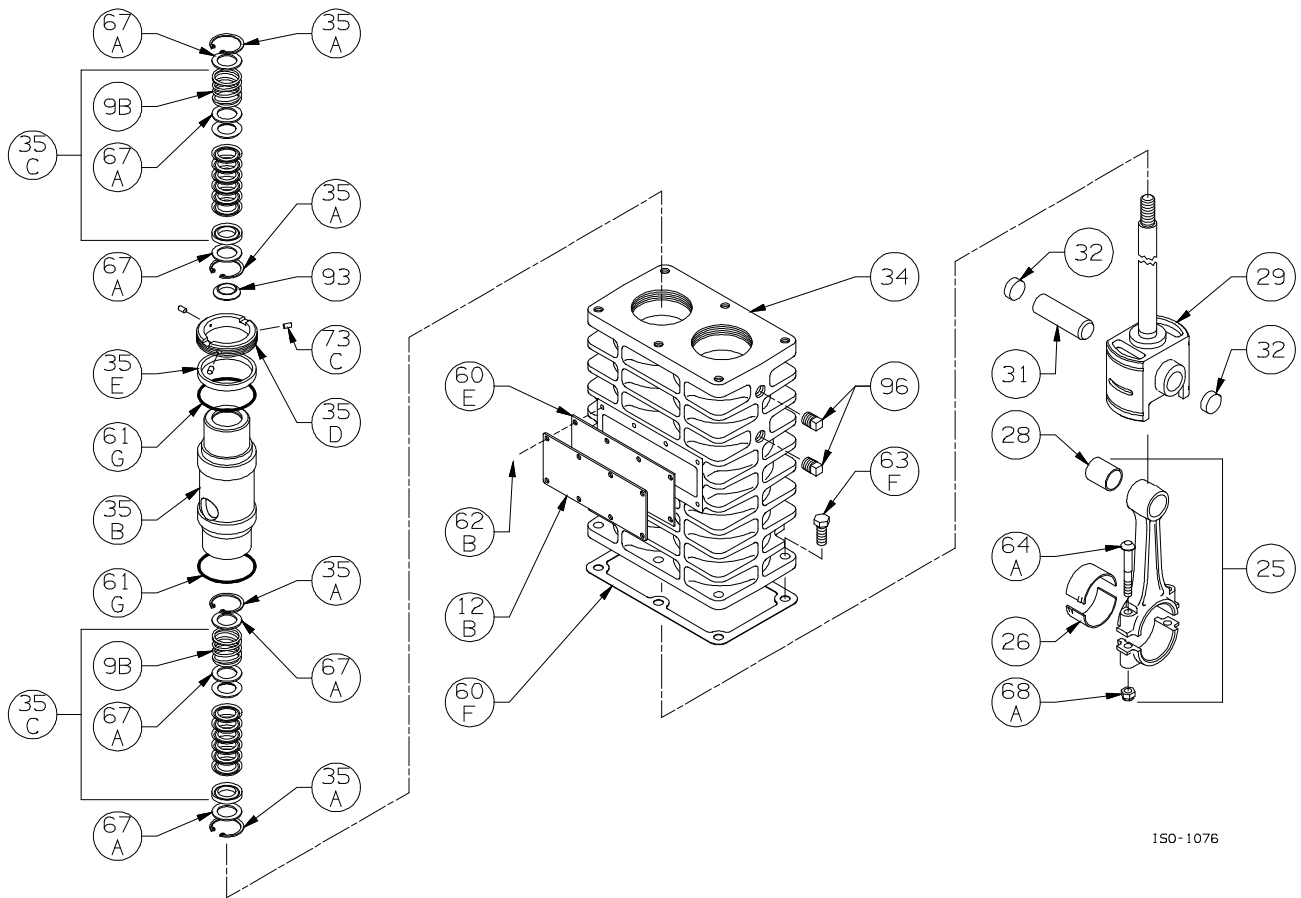

150-1076

Crosshead

Ref	Description	Qty	Part No
9B	Packing Spring – Stainless Steel	4	793503
12B	Inspection Plate	1	792017
25	Connecting Rod Assembly	2	792301
26	Connecting Rod Bearing	2	792012
28	Wrist Pin Bearing	2	792302
29	Crosshead Assy (top marked '90k')	2	792501
31	Wrist Pin	2	792014
32	Wrist Pin Plug	4	792178
34	Crosshead Guide	1	792455
35A	Retainer Ring – Stainless Steel	8	793504
35B	Packing Box (top marked '1018')	2	792502
35C	Packing Set	4	793506
35D	Hold-down Ring	2	793220

ISO1076

Ref	Description	Qty	Part No
35E	Spacer Ring	2	793402
60E	Gasket - Inspection Plate *	1	792092
60F	Gasket - Crankcase *	1	792121
61G	O-Ring (FKM) *	4	793213
62B	Machine Screw - Inspection Plate	8	793096
63F	Capscrew - Stainless Steel	6	098392
64A	Connecting Rod Bolt	4	792006
67A	Washer - Packing Box	12	792087
68A	Connecting Rod Bolt Nut	4	792005
73C	Lock Plug *	6	792030
93	Oil Deflector Ring	2	793478
96	Pipe Plug	4	908198

*Included in Gasket Sets

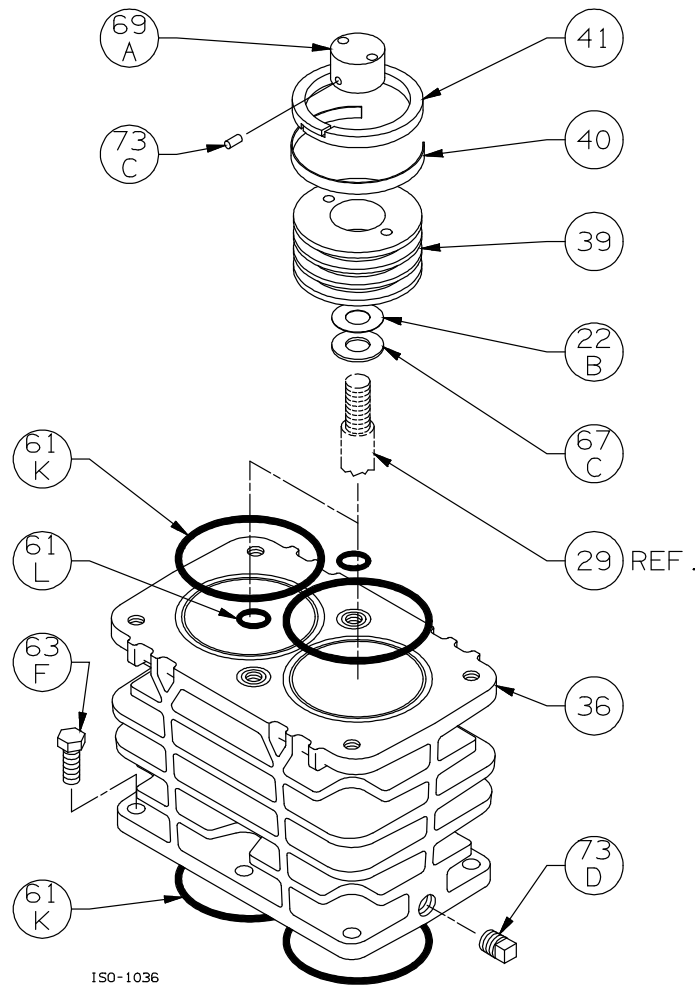

ISO-1036

Cylinder: ISO1036

Ref	Description	Qty	Part No
22B	Piston Shim - 0.015	AR	792034
	Piston Shim - 0.007		792050
36	Cylinder	1	792101
39	Piston	2	792431
40	Expander	6	794615
41	Piston Ring – Glass/Moly Filled	6	792420
61K	O-Ring (FKM) *	4	792213

Ref	Description	Qty	Part No
61L	O-Ring (FKM) *	2	792212
63F	Capscrew - Stainless Steel	6	098392
67C	Thrust Washer	2	792033
69A	Piston Nut	2	793022
73C	Lock Plug *	4	793028
73D	Pipe Plug	1	908198

* Included in Gasket Sets

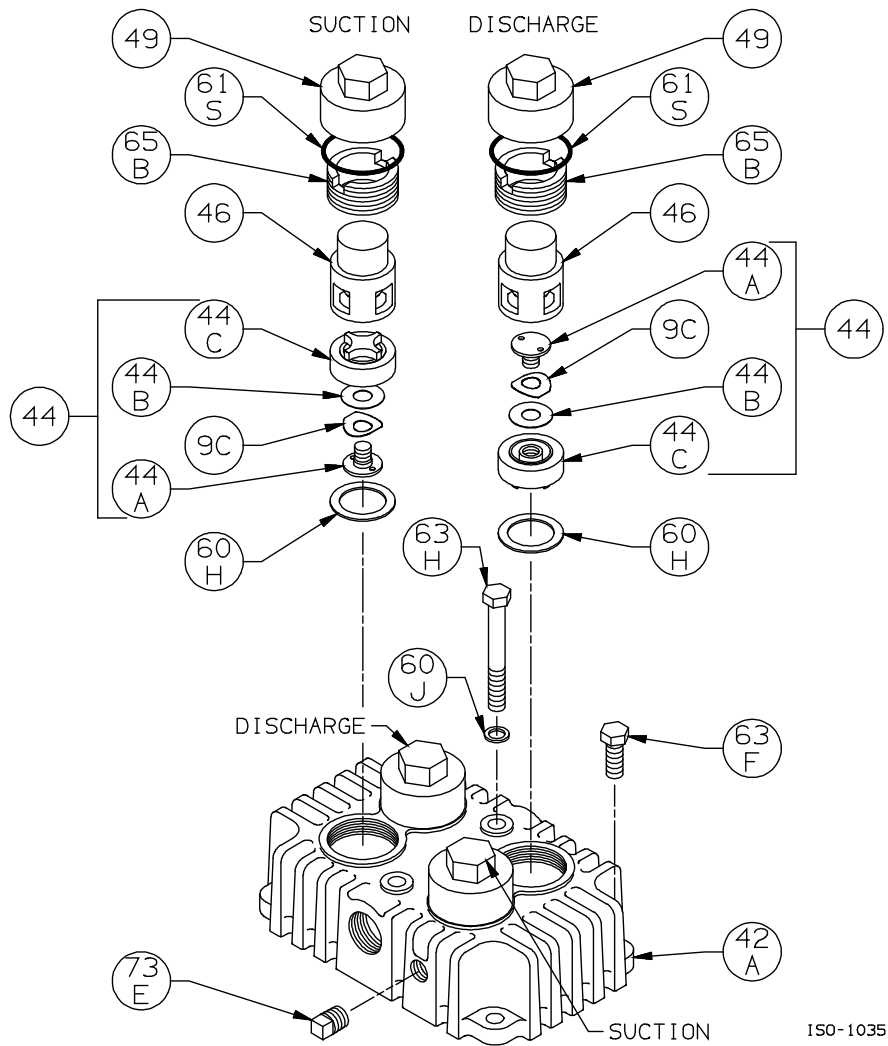

Head Assembly:

ISO1035

Ref	Description	Qty	Part No
9C	Valve Spring	4	792038
42A	Head	1	792111
44	Valve Assembly	4	792056
44A	Valve Bumper	4	792054
44B	Valve Disc	4	792037
44C	Valve Body	4	792055
46	Cage	4	792051
49	Valve Cap	4	792003

Ref	Description	Qty	Part No
60H	Gasket - Valve *	4	792201
60J	Gasket - Center Head Bolt *	2	792203
61S	O-Ring (FKM) *	4	792308
63F	Capscrew - Hex Hd - Stainless Steel	4	098392
63H	Capscrew - Hex Hd - Stainless Steel	2	920428
65B	Valve Holddown Screw	4	792002
73E	Pipe Plug	2	908198

* Included in Gasket Sets

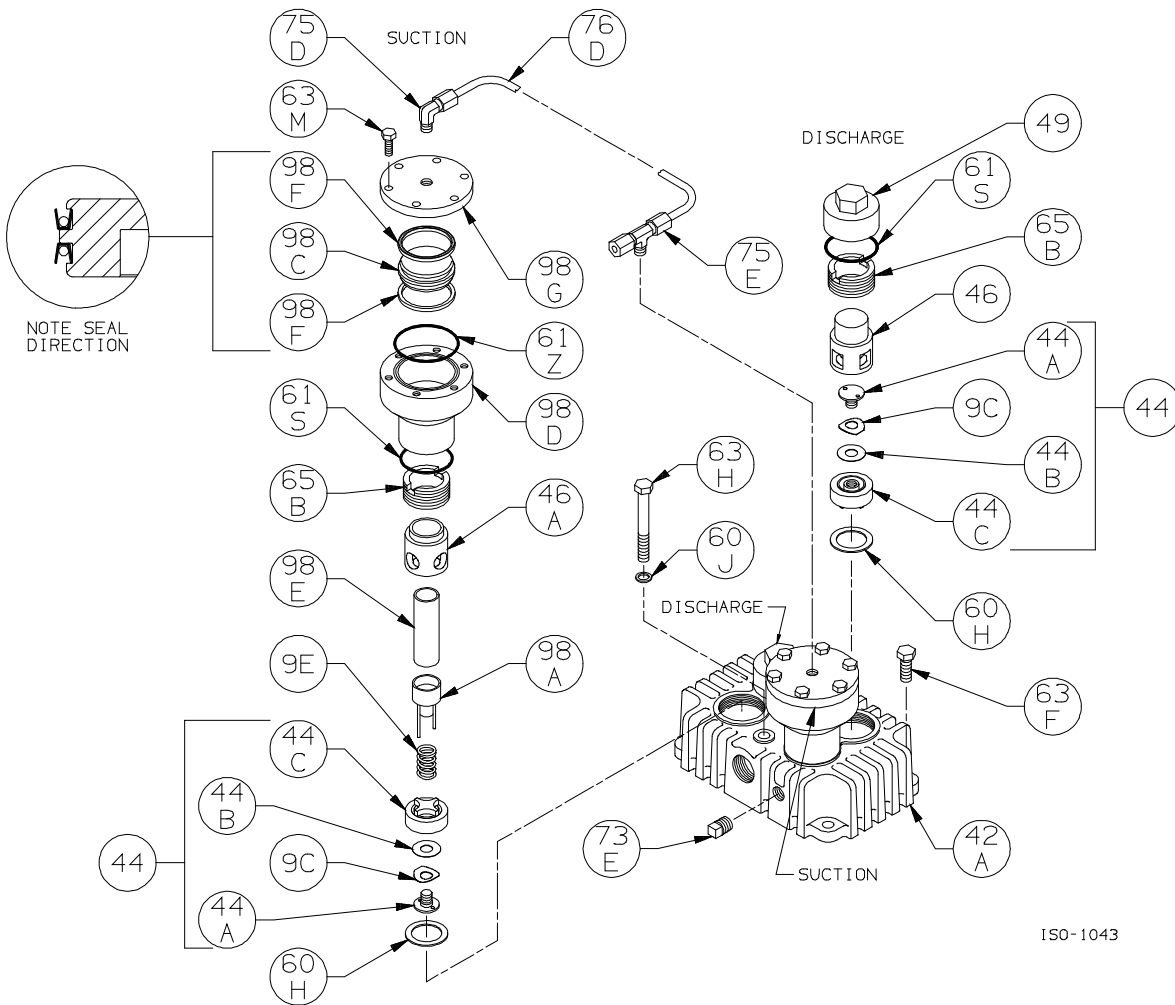

ISO-1043

Head Assembly with Unloaders:

Ref	Description	Qty	Part No
9C	Valve Spring	4	792038
9E	Unloader Spring	2	793293
42A	Head	1	792111
44	Valve Assembly	4	792056
44A	Valve Bumper	4	792054
44B	Valve Disc	4	792037
44C	Valve Body	4	792055
46	Cage	2	792051
46A	Cage	2	792282
49	Valve Cap	2	792003
60H	Gasket - Valve *	4	792201
60J	Gasket - Center Head Bolt *	2	792203
61S	O-Ring (FKM) *	4	792308
61Z	O-Ring (FKM) *	2	792313

ISO1043

Ref	Description	Qty	Part No
63F	Capscrew - Hex Hd - Stainless Steel	4	098392
63H	Capscrew - Hex Hd - Stainless Steel	2	920428
63M	Capscrew - Hex Hd	12	797093
65B	Valve Holddown Screw	4	792002
73E	Pipe Plug	2	908198
75D	Tube Elbow	1	790355
75E	Tube Tee	1	790356
76D	Tube	1	790192
98A	Actuator Assembly	2	792296
98C	Unloader Piston	2	793288
98D	Unloader Body	2	792286
98E	Unloader Plunger	2	793290
98F	Unloader Seal	4	792284
98G	Unloader Cap	2	793287

* Included in Gasket Sets

Suggested Spares

Part #	Description	Qty./Unit	Comm. Qty.	Spare Qty.
792596	Gasket Set - FKM	1	1	1
792056	Suction Valve	2		2
792056	Discharge Valve	2		2
792420	Piston Ring - Glass/Moly Filled	6	6	6
794615	Piston Ring Expander	6	6	6
793506	Packing Set	4	4	4
794726	Oil Filter	1		6
792014	Wrist Pin	2		2
792302	Wrist Pin Bearing	2	2	2
792012	Conrod Bearing	2	2	2
The following parts would normally be required only for major compressor overhaul.				
793142	Bearing Cone	2		2
793126	Bearing Cup	2		2
792501	Crosshead Assembly	2		1
792301	Conrod Assembly	2		1
794760	Oil Pump Repair Kit	1		
792157	Crankshaft Assembly	1		
793133	Bearing Adjustment Shim Kit	1		
792101	Cylinder	1		

Notes:

Notes:

Notes: