



TYPE	SIZE	UNIT STYLE
SGL	4	SK52W

DIMENSIONS 801-H13	
Section Effective Replaces Page 1 / 1	801 Dec 2023 Sept 2023

RIGHT HAND ROTATION SHOWN. FOR LEFT HAND ROTATION, SHAFT IS OPPOSITE THAT SHOWN.

MOUNTING STYLE: LONG COUPLED

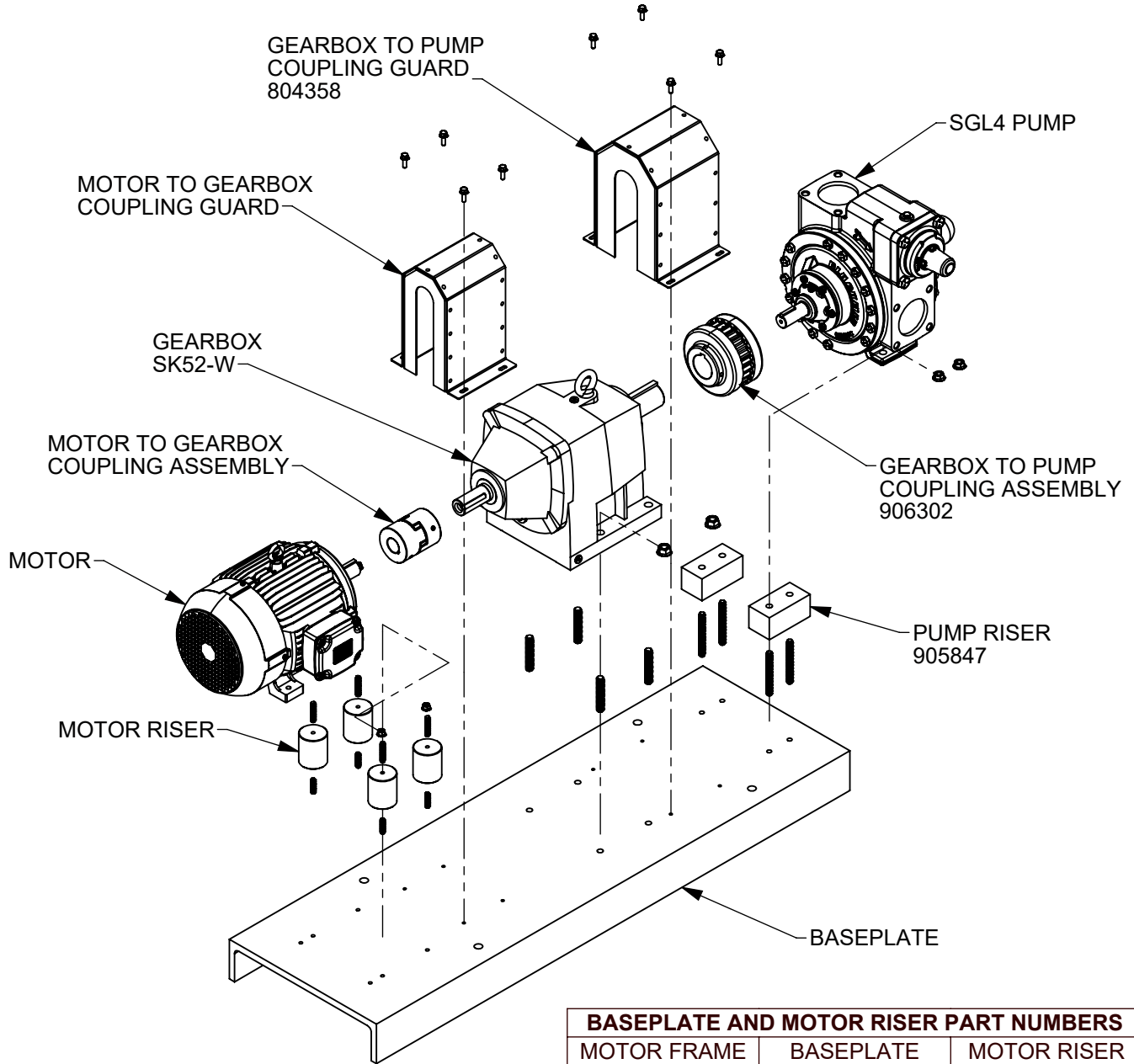

BASEPLATE AND MOTOR RISER PART NUMBERS		
MOTOR FRAME	BASEPLATE	MOTOR RISER
213T/215T	901461	905848
254T/256T	901463	905849
284T/286T	901464	905850
COUPLING AND GUARD PART NUMBERS		
MOTOR FRAME	MOTOR TO GEARBOX COUPLING ASSY	MOTOR TO GEARBOX COUPLING GUARD
213T/215T	906314	804323
254T/256T	906319	804323
284T/286T	906320	804332

NORD SK52-W GEARBOX PART NUMBERS		
RATIO	SPEEDS 60Hz/50Hz	PART NUMBER
2.78:1	629 RPM / 522 RPM	812700
3.23:1	542 RPM / 449 RPM	812701
3.40:1	515 RPM / 426 RPM	812702
3.67:1	477 RPM / 395 RPM	812703
4.08:1	429 RPM / 355 RPM	812704
4.38:1	400 RPM / 331 RPM	812705
4.61:1	380 RPM / 315 RPM	812706